

# *The European Union*

## EDICT OF GOVERNMENT

In order to promote public education and public safety, equal justice for all, a better informed citizenry, the rule of law, world trade and world peace, this legal document is hereby made available on a noncommercial basis, as it is the right of all humans to know and speak the laws that govern them.

EN 1998-2 (2005) (English): Eurocode 8: Design of structures for earthquake resistance – Part 2: Bridges [Authority: The European Union Per Regulation 305/2011, Directive 98/34/EC, Directive 2004/18/EC]



BLANK PAGE



ICS 91.120.25; 93.040

Supersedes ENV 1998-2:1994  
Incorporating corrigendum February 2010

English Version

## Eurocode 8 - Design of structures for earthquake resistance - Part 2: Bridges

Eurocode 8 - Calcul des structures pour leur résistance aux  
séismes - Partie 2: Ponts

Eurocode 8 - Auslegung von Bauwerken gegen Erdbeben -  
Teil 2: Brücken

This European Standard was approved by CEN on 7 July 2005.

CEN members are bound to comply with the CEN/CENELEC Internal Regulations which stipulate the conditions for giving this European Standard the status of a national standard without any alteration. Up-to-date lists and bibliographical references concerning such national standards may be obtained on application to the Central Secretariat or to any CEN member.

This European Standard exists in three official versions (English, French, German). A version in any other language made by translation under the responsibility of a CEN member into its own language and notified to the Central Secretariat has the same status as the official versions.

CEN members are the national standards bodies of Austria, Belgium, Cyprus, Czech Republic, Denmark, Estonia, Finland, France, Germany, Greece, Hungary, Iceland, Ireland, Italy, Latvia, Lithuania, Luxembourg, Malta, Netherlands, Norway, Poland, Portugal, Slovakia, Slovenia, Spain, Sweden, Switzerland and United Kingdom.

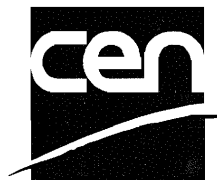

EUROPEAN COMMITTEE FOR STANDARDIZATION  
COMITÉ EUROPÉEN DE NORMALISATION  
EUROPÄISCHES KOMITEE FÜR NORMUNG

Management Centre: rue de Stassart, 36 B-1050 Brussels

---

## TABLE OF CONTENTS

<b>FOREWORD</b> .....	<b>6</b>
<b>1 INTRODUCTION</b> .....	<b>12</b>
1.1 SCOPE .....	12
1.1.1 <i>Scope of EN 1998-2</i> .....	12
1.1.2 <i>Further parts of EN 1998</i> .....	13
1.2 NORMATIVE REFERENCES .....	13
1.2.1 <i>Use</i> .....	13
1.2.2 <i>General reference standards</i> .....	13
1.2.3 <i>Reference Codes and Standards</i> .....	13
1.2.4 <i>Additional general and other reference standards for bridges</i> .....	13
1.3 ASSUMPTIONS .....	14
1.4 DISTINCTION BETWEEN PRINCIPLES AND APPLICATION RULES .....	14
1.5 DEFINITIONS .....	14
1.5.1 <i>General</i> .....	14
1.5.2 <i>Terms common to all Eurocodes</i> .....	14
1.5.3 <i>Further terms used in EN 1998-2</i> .....	14
1.6 SYMBOLS .....	16
1.6.1 <i>General</i> .....	16
1.6.2 <i>Further symbols used in Sections 2 and 3 of EN 1998-2</i> .....	16
1.6.3 <i>Further symbols used in Section 4 of EN 1998-2</i> .....	17
1.6.4 <i>Further symbols used in Section 5 of EN 1998-2</i> .....	18
1.6.5 <i>Further symbols used in Section 6 of EN 1998-2</i> .....	19
1.6.6 <i>Further symbols used in Section 7 and Annexes J, JJ and K of EN 1998-2</i> .....	21
<b>2 BASIC REQUIREMENTS AND COMPLIANCE CRITERIA</b> .....	<b>24</b>
2.1 DESIGN SEISMIC ACTION .....	24
2.2 BASIC REQUIREMENTS .....	25
2.2.1 <i>General</i> .....	25
2.2.2 <i>No-collapse (ultimate limit state)</i> .....	25
2.2.3 <i>Minimisation of damage (serviceability limit state)</i> .....	26
2.3 COMPLIANCE CRITERIA .....	26
2.3.1 <i>General</i> .....	26
2.3.2 <i>Intended seismic behaviour</i> .....	26
2.3.3 <i>Resistance verifications</i> .....	29
2.3.4 <i>Capacity design</i> .....	29
2.3.5 <i>Provisions for ductility</i> .....	29
2.3.6 <i>Connections - Control of displacements - Detailing</i> .....	32
2.3.7 <i>Simplified criteria</i> .....	36
2.4 CONCEPTUAL DESIGN .....	36
<b>3 SEISMIC ACTION</b> .....	<b>39</b>
3.1 DEFINITION OF THE SEISMIC ACTION .....	39
3.1.1 <i>General</i> .....	39
3.1.2 <i>Application of the components of the motion</i> .....	39
3.2 QUANTIFICATION OF THE COMPONENTS .....	39
3.2.1 <i>General</i> .....	39

3.2.2	<i>Site dependent elastic response spectrum</i> .....	40
3.2.3	<i>Time-history representation</i> .....	40
3.2.4	<i>Site dependent design spectrum for linear analysis</i> .....	41
3.3	SPATIAL VARIABILITY OF THE SEISMIC ACTION .....	41
<b>4</b>	<b>ANALYSIS</b> .....	<b>45</b>
4.1	MODELLING .....	45
4.1.1	<i>Dynamic degrees of freedom</i> .....	45
4.1.2	<i>Masses</i> .....	45
4.1.3	<i>Damping of the structure and stiffness of members</i> .....	46
4.1.4	<i>Modelling of the soil</i> .....	46
4.1.5	<i>Torsional effects</i> .....	47
4.1.6	<i>Behaviour factors for linear analysis</i> .....	48
4.1.7	<i>Vertical component of the seismic action</i> .....	51
4.1.8	<i>Regular and irregular seismic behaviour of ductile bridges</i> .....	51
4.1.9	<i>Non-linear analysis of irregular bridges</i> .....	52
4.2	METHODS OF ANALYSIS .....	52
4.2.1	<i>Linear dynamic analysis - Response spectrum method</i> .....	52
4.2.2	<i>Fundamental mode method</i> .....	54
4.2.3	<i>Alternative linear methods</i> .....	58
4.2.4	<i>Non-linear dynamic time-history analysis</i> .....	58
4.2.5	<i>Static non-linear analysis (pushover analysis)</i> .....	60
<b>5</b>	<b>STRENGTH VERIFICATION</b> .....	<b>62</b>
5.1	GENERAL .....	62
5.2	MATERIALS AND DESIGN STRENGTH .....	62
5.2.1	<i>Materials</i> .....	62
5.2.2	<i>Design strength</i> .....	62
5.3	CAPACITY DESIGN .....	62
5.4	SECOND ORDER EFFECTS .....	64
5.5	COMBINATION OF THE SEISMIC ACTION WITH OTHER ACTIONS .....	65
5.6	RESISTANCE VERIFICATION OF CONCRETE SECTIONS .....	66
5.6.1	<i>Design resistance</i> .....	66
5.6.2	<i>Structures of limited ductile behaviour</i> .....	66
5.6.3	<i>Structures of ductile behaviour</i> .....	66
5.7	RESISTANCE VERIFICATION FOR STEEL AND COMPOSITE MEMBERS .....	74
5.7.1	<i>Steel piers</i> .....	74
5.7.2	<i>Steel or composite deck</i> .....	75
5.8	FOUNDATIONS .....	75
5.8.1	<i>General</i> .....	75
5.8.2	<i>Design action effects</i> .....	76
5.8.3	<i>Resistance verification</i> .....	76
<b>6</b>	<b>DETAILING</b> .....	<b>77</b>
6.1	GENERAL .....	77
6.2	CONCRETE PIERS .....	77
6.2.1	<i>Confinement</i> .....	77
6.2.2	<i>Buckling of longitudinal compression reinforcement</i> .....	81
6.2.3	<i>Other rules</i> .....	82
6.2.4	<i>Hollow piers</i> .....	83
6.3	STEEL PIERS .....	83

6.4	FOUNDATIONS.....	83
6.4.1	<i>Spread foundation</i> .....	83
6.4.2	<i>Pile foundations</i> .....	83
6.5	STRUCTURES OF LIMITED DUCTILE BEHAVIOUR.....	84
6.5.1	<i>Verification of ductility of critical sections</i> .....	84
6.5.2	<i>Avoidance of brittle failure of specific non-ductile components</i> .....	84
6.6	BEARINGS AND SEISMIC LINKS.....	85
6.6.1	<i>General requirements</i> .....	85
6.6.2	<i>Bearings</i> .....	86
6.6.3	<i>Seismic links, holding-down devices, shock transmission units</i> .....	87
6.6.4	<i>Minimum overlap lengths</i> .....	89
6.7	CONCRETE ABUTMENTS AND RETAINING WALLS.....	91
6.7.1	<i>General requirements</i> .....	91
6.7.2	<i>Abutments flexibly connected to the deck</i> .....	91
6.7.3	<i>Abutments rigidly connected to the deck</i> .....	91
6.7.4	<i>Culverts with large overburden</i> .....	93
6.7.5	<i>Retaining walls</i> .....	94
<b>7</b>	<b>BRIDGES WITH SEISMIC ISOLATION.....</b>	<b>95</b>
7.1	GENERAL.....	95
7.2	DEFINITIONS.....	95
7.3	BASIC REQUIREMENTS AND COMPLIANCE CRITERIA.....	96
7.4	SEISMIC ACTION.....	97
7.4.1	<i>Design spectra</i> .....	97
7.4.2	<i>Time-history representation</i> .....	97
7.5	ANALYSIS PROCEDURES AND MODELLING.....	97
7.5.1	<i>General</i> .....	97
7.5.2	<i>Design properties of the isolating system</i> .....	98
7.5.3	<i>Conditions for application of analysis methods</i> .....	104
7.5.4	<i>Fundamental mode spectrum analysis</i> .....	104
7.5.5	<i>Multi-mode Spectrum Analysis</i> .....	108
7.5.6	<i>Time history analysis</i> .....	109
7.5.7	<i>Vertical component of seismic action</i> .....	109
7.6	VERIFICATIONS.....	109
7.6.1	<i>Seismic design situation</i> .....	109
7.6.2	<i>Isolating system</i> .....	109
7.6.3	<i>Substructures and superstructure</i> .....	111
7.7	SPECIAL REQUIREMENTS FOR THE ISOLATING SYSTEM.....	112
7.7.1	<i>Lateral restoring capability</i> .....	112
7.7.2	<i>Lateral restraint at the isolation interface</i> .....	117
7.7.3	<i>Inspection and Maintenance</i> .....	117
	<b>ANNEX A (INFORMATIVE) PROBABILITIES RELATED TO THE REFERENCE SEISMIC ACTION. GUIDANCE FOR THE SELECTION OF DESIGN SEISMIC ACTION DURING THE CONSTRUCTION PHASE.....</b>	<b>118</b>
	<b>ANNEX B (INFORMATIVE) RELATIONSHIP BETWEEN DISPLACEMENT DUCTILITY AND CURVATURE DUCTILITY FACTORS OF PLASTIC HINGES IN CONCRETE PIERS.....</b>	<b>119</b>
	<b>ANNEX C (INFORMATIVE) ESTIMATION OF THE EFFECTIVE STIFFNESS OF REINFORCED CONCRETE DUCTILE MEMBERS.....</b>	<b>120</b>

<b>ANNEX D (INFORMATIVE) SPATIAL VARIABILITY OF EARTHQUAKE GROUND MOTION: MODEL AND METHODS OF ANALYSIS .....</b>	<b>122</b>
<b>ANNEX E (INFORMATIVE) PROBABLE MATERIAL PROPERTIES AND PLASTIC HINGE DEFORMATION CAPACITIES FOR NON-LINEAR ANALYSES .....</b>	<b>129</b>
<b>ANNEX F (INFORMATIVE) ADDED MASS OF ENTRAINED WATER FOR IMMERSSED PIERS.....</b>	<b>135</b>
<b>ANNEX G (NORMATIVE) CALCULATION OF CAPACITY DESIGN EFFECTS .....</b>	<b>137</b>
<b>ANNEX H (INFORMATIVE) STATIC NON-LINEAR ANALYSIS (PUSHOVER) .....</b>	<b>139</b>
<b>ANNEX J (NORMATIVE) VARIATION OF DESIGN PROPERTIES OF SEISMIC ISOLATOR UNITS.....</b>	<b>142</b>
<b>ANNEX JJ (INFORMATIVE) <math>\lambda</math>-FACTORS FOR COMMON ISOLATOR TYPES .....</b>	<b>144</b>
<b>ANNEX K (INFORMATIVE) TESTS FOR VALIDATION OF DESIGN PROPERTIES OF SEISMIC ISOLATOR UNITS.....</b>	<b>147</b>

## Foreword

This European Standard EN 1998-2, Eurocode 8: Design of structures for earthquake resistance: Bridges, has been prepared by Technical Committee CEN/TC250 «Structural Eurocodes», the Secretariat of which is held by BSI. CEN/TC250 is responsible for all Structural Eurocodes.

This European Standard shall be given the status of a National Standard, either by publication of an identical text or by endorsement, at the latest by May 2006, and conflicting national standards shall be withdrawn at latest by March 2010.

This document supersedes ENV 1998-2:1994.

According to the CEN-CENELEC Internal Regulations, the National Standard Organisations of the following countries are bound to implement this European Standard: Austria, Belgium, Cyprus, Czech Republic, Denmark, Estonia, Finland, France, Germany, Greece, Hungary, Iceland, Ireland, Italy, Latvia, Lithuania, Luxembourg, Malta, Netherlands, Norway, Poland, Portugal, Slovakia, Slovenia, Spain, Sweden, Switzerland and United Kingdom.

## Background of the Eurocode programme

In 1975, the Commission of the European Community decided on an action programme in the field of construction, based on article 95 of the Treaty. The objective of the programme was the elimination of technical obstacles to trade and the harmonisation of technical specifications.

Within this action programme, the Commission took the initiative to establish a set of harmonised technical rules for the design of construction works which, in a first stage, would serve as an alternative to the national rules in force in the Member States and, ultimately, would replace them.

For fifteen years, the Commission, with the help of a Steering Committee with Representatives of Member States, conducted the development of the Eurocodes programme, which led to the first generation of European codes in the 1980s.

In 1989, the Commission and the Member States of the EU and EFTA decided, on the basis of an agreement<sup>1</sup> between the Commission and CEN, to transfer the preparation and the publication of the Eurocodes to CEN through a series of Mandates, in order to provide them with a future status of European Standard (EN). This links *de facto* the Eurocodes with the provisions of all the Council's Directives and/or Commission's Decisions dealing with European standards (*e.g.* the Council Directive 89/106/EEC on construction products - CPD - and Council Directives 93/37/EEC, 92/50/EEC and 89/440/EEC on public works and services and equivalent EFTA Directives initiated in pursuit of setting up the internal market).

---

<sup>1</sup> Agreement between the Commission of the European Communities and the European Committee for Standardisation (CEN) concerning the work on EUROCODES for the design of building and civil engineering works (BC/CEN/03/89).



The Structural Eurocode programme comprises the following standards generally consisting of a number of Parts:

EN 1990	Eurocode:	Basis of structural design
EN 1991	Eurocode 1:	Actions on structures
EN 1992	Eurocode 2:	Design of concrete structures
EN 1993	Eurocode 3:	Design of steel structures
EN 1994	Eurocode 4:	Design of composite steel and concrete structures
EN 1995	Eurocode 5:	Design of timber structures
EN 1996	Eurocode 6:	Design of masonry structures
EN 1997	Eurocode 7:	Geotechnical design
EN 1998	Eurocode 8:	Design of structures for earthquake resistance
EN 1999	Eurocode 9:	Design of aluminium structures

Eurocode standards recognise the responsibility of regulatory authorities in each Member State and have safeguarded their right to determine values related to regulatory safety matters at national level where these continue to vary from State to State.

### Status and field of application of Eurocodes

The Member States of the EU and EFTA recognise that Eurocodes serve as reference documents for the following purposes:

- as a means to prove compliance of building and civil engineering works with the essential requirements of Council Directive 89/106/EEC, particularly Essential Requirement N°1 – Mechanical resistance and stability – and Essential Requirement N°2 – Safety in case of fire;
- as a basis for specifying contracts for construction works and related engineering services;
- as a framework for drawing up harmonised technical specifications for construction products (ENs and ETAs).

The Eurocodes, as far as they concern the construction works themselves, have a direct relationship with the Interpretative Documents<sup>2</sup> referred to in Article 12 of the CPD, although they are of a different nature from harmonised product standards<sup>3</sup>. Therefore, technical aspects arising from the Eurocodes work need to be adequately considered by

---

<sup>2</sup> In accordance with Art. 3.3 of the CPD, the essential requirements (ERs) shall be given concrete form in interpretative documents for the creation of the necessary links between the essential requirements and the mandates for harmonised ENs and ETAGs/ETAs.

<sup>3</sup> In accordance with Art. 12 of the CPD the interpretative documents shall:

- a) give concrete form to the essential requirements by harmonising the terminology and the technical bases and indicating classes or levels for each requirement where necessary ;
- b) indicate methods of correlating these classes or levels of requirement with the technical specifications, e.g. methods of calculation and of proof, technical rules for project design, etc.;
- c) serve as a reference for the establishment of harmonised standards and guidelines for European technical approvals.

The Eurocodes, de facto, play a similar role in the field of the ER 1 and a part of ER 2.

CEN Technical Committees and/or EOTA Working Groups working on product standards with a view to achieving full compatibility of these technical specifications with the Eurocodes.

The Eurocode standards provide common structural design rules for everyday use for the design of whole structures and component products of both a traditional and an innovative nature. Unusual forms of construction or design conditions are not specifically covered and additional expert consideration will be required by the designer in such cases.

### **National Standards implementing Eurocodes**

The National Standards implementing Eurocodes will comprise the full text of the Eurocode (including any annexes), as published by CEN, which may be preceded by a National title page and National foreword, and may be followed by a National annex.

The National annex may only contain information on those parameters which are left open in the Eurocode for national choice, known as Nationally Determined Parameters, to be used for the design of buildings and civil engineering works to be constructed in the country concerned, *i.e.*:

- values and/or classes where alternatives are given in the Eurocode,
- values to be used where a symbol only is given in the Eurocode,
- country specific data (geographical, climatic, etc.), e.g. snow map,
- the procedure to be used where alternative procedures are given in the Eurocode.

It may also contain

- decisions on the use of informative annexes, and
- references to non-contradictory complementary information to assist the user to apply the Eurocode.

### **Links between Eurocodes and harmonised technical specifications (ENs and ETAs) for products**

There is a need for consistency between the harmonised technical specifications for construction products and the technical rules for works<sup>4</sup>. Furthermore, all the information accompanying the CE Marking of the construction products which refer to Eurocodes shall clearly mention which Nationally Determined Parameters have been taken into account.

### **Additional information specific to EN 1998-2**

The scope of this Part of EN 1998 is defined in **1.1**.

Except where otherwise specified in this Part, the seismic actions are as defined in EN 1998-1:2004, Section **3**.

---

<sup>4</sup> see Art.3.3 and Art.12 of the CPD, as well as 4.2, 4.3.1, 4.3.2 and 5.2 of ID 1.

Due to the peculiarities of the bridge seismic resisting systems, in comparison to those of buildings and other structures, all other sections of this Part are in general not directly related to those of EN 1998-1:2004. However several provisions of EN 1998-1:2004 are used by direct reference.

Since the seismic action is mainly resisted by the piers and the latter are usually constructed of reinforced concrete, a greater emphasis has been given to such piers.

Bearings are in many cases important parts of the seismic resisting system of a bridge and are therefore treated accordingly. The same holds for seismic isolation devices.

### National annex for EN 1998-2

This standard gives alternative procedures, values and recommendations for classes, with notes indicating where national choices may have to be made. Therefore the National Standard implementing EN 1998-2 should have a National annex containing all Nationally Determined Parameters to be used for the design of buildings and civil engineering works to be constructed in the relevant country.

National choice is allowed in EN 1998-2:2005 through clauses:

Reference	Item
1.1.1(8)	Informative Annexes A, B, C, D, E, F, <span style="border: 1px solid black; padding: 0 2px;">AC1</span> H, JJ and K <span style="border: 1px solid black; padding: 0 2px;">AC1</span>
2.1(3)P	Reference return period $T_{NCR}$ of seismic action for the no-collapse requirement of the bridge (or, equivalently, reference probability of exceedance in 50 years, $P_{NCR}$ ).
2.1(4)P	Importance classes for bridges
2.1(6)	Importance factors for bridges
2.2.2(5)	Conditions under which the seismic action may be considered as accidental action, and the requirements of <b>2.2.2(3)</b> and <b>2.2.2 (4)</b> may be relaxed.
2.3.5.3(1)	Expression for the length of plastic hinges
2.3.6.3(5)	Fractions of design displacements for non-critical structural elements
2.3.7(1)	Cases of low seismicity
2.3.7(1)	Simplified criteria for the design of bridges in cases of low seismicity
3.2.2.3	Definition of active fault
3.3(1)P	Length of continuous deck beyond which the spatial variability of seismic action may have to be taken into account
3.3(6)	Distance beyond which the seismic ground motions may be considered as completely uncorrelated
3.3(6)	factor accounting for the magnitude of ground displacements occurring in opposite direction at adjacent supports
4.1.2(4)P	$\psi_{21}$ values for traffic loads assumed concurrent with the design seismic action
4.1.8(2)	Upper limit for the value in the left-hand-side of expression (4.4) for the seismic behaviour of a bridge to be considered irregular

5.3(4)	Value of overstrength factor $\gamma_0$
5.4(1)	Simplified methods for second order effects in linear analysis
5.6.2(2)P b	Value of additional safety factor $\gamma_{Bd1}$ on shear resistance
5.6.3.3(1)P b	Alternatives for determination of additional safety factor $\gamma_{Bd}$ on shear resistance of ductile members outside plastic hinges
6.2.1.4(1)P	Type of confinement reinforcement
6.5.1(1)P	Simplified verification rules for bridges of limited ductile behaviour in low seismicity cases
6.6.2.3(3)	Allowable extent of damage of elastomeric bearings in bridges where the seismic action is considered as accidental action, but is not resisted entirely by elastomeric bearings
6.6.3.2(1)P	Percentage of the compressive (downward) reaction due to the permanent load that is exceeded by the total vertical reaction on a support due to the design seismic action, for holding-down devices to be required.
6.7.3(7)	Upper value of design seismic displacement to limit damage of the soil or embankment behind abutments rigidly connected to the deck.
7.4.1(1)P	Value of control period $T_D$ for the design spectrum of bridges with seismic isolation
7.6.2(1)P	Value of amplification factor $\gamma_S$ on design displacement of isolator units
7.6.2(5)	Value of $\gamma_m$ for elastomeric bearings
7.7.1(2)	$\langle AC1 \rangle$ Values of the ratio $\delta$ for the evaluation of the lateral restoring capability
7.7.1(4)	Value of $\gamma_{du}$ reflecting uncertainties in the estimation of design displacements $\langle AC1 \rangle$
J.1(2)	Values of minimum isolator temperature in the seismic design situation
J.2(1)	Values of $\lambda$ -factors for commonly used isolators

## Foreword to amendment A1

This document (EN 1998-2:2005/A1:2009) has been prepared by Technical Committee CEN/TC 250 "Structural Eurocodes", the secretariat of which is held by BSI.

This Amendment to the European Standard EN 1998-2:2005 shall be given the status of a national standard, either by publication of an identical text or by endorsement, at the latest by September 2009, and conflicting national standards shall be withdrawn at the latest by March 2010.

Attention is drawn to the possibility that some of the elements of this document may be the subject of patent rights. CEN [and/or CENELEC] shall not be held responsible for identifying any or all such patent rights.

According to the CEN/CENELEC Internal Regulations, the national standards organizations of the following countries are bound to implement this European Standard: Austria, Belgium, Bulgaria, Cyprus, Czech Republic, Denmark, Estonia, Finland, France, Germany, Greece, Hungary, Iceland, Ireland, Italy, Latvia, Lithuania, Luxembourg, Malta, Netherlands, Norway, Poland, Portugal, Romania, Slovakia, Slovenia, Spain, Sweden, Switzerland and United Kingdom.

## Foreword to amendment A2

This document (EN 1998-2:2005/A2:2011) has been prepared by Technical Committee CEN/TC “Structural Eurocodes”, the secretariat of which is held by BSI.

This Amendment to the European Standard EN 1998-2:2005 shall be given the status of a national standard, either by publication of an identical text or by endorsement, at the latest by September 2012, and conflicting national standards shall be withdrawn at the latest by September 2012.

Attention is drawn to the possibility that some of the elements of this document may be the subject of patent rights. CEN [and/or CENELEC] shall not be held responsible for identifying any or all such patent rights.

According to the CEN/CENELEC Internal Regulations, the national standards organizations of the following countries are bound to implement this European Standard: Austria, Belgium, Bulgaria, Croatia, Cyprus, Czech Republic, Denmark, Estonia, Finland, France, Germany, Greece, Hungary, Iceland, Ireland, Italy, Latvia, Lithuania, Luxembourg, Malta, Netherlands, Norway, Poland, Portugal, Romania, Slovakia, Slovenia, Spain, Sweden, Switzerland and the United Kingdom.

## 1 INTRODUCTION

### 1.1 Scope

#### 1.1.1 Scope of EN 1998-2

(1) The scope of Eurocode 8 is defined in EN 1998-1:2004, **1.1.1** and the scope of this Standard is defined in **1.1.1**. Additional parts of Eurocode 8 are indicated in EN 1998-1:2004, **1.1.3**.

(2) Within the framework of the scope set forth in EN 1998-1:2004, this part of the Standard contains the particular Performance Requirements, Compliance Criteria and Application Rules applicable to the design of earthquake resistant bridges.

(3) This Part primarily covers the seismic design of bridges in which the horizontal seismic actions are mainly resisted through bending of the piers or at the abutments; i.e. of bridges composed of vertical or nearly vertical pier systems supporting the traffic deck superstructure. It is also applicable to the seismic design of cable-stayed and arched bridges, although its provisions should not be considered as fully covering these cases.

(4) Suspension bridges, timber and masonry bridges, moveable bridges and floating bridges are not included in the scope of this Part.

(5) This Part contains only those provisions that, in addition to other relevant Eurocodes or relevant Parts of EN 1998, should be observed for the design of bridges in seismic regions. In cases of low seismicity, simplified design criteria may be established (see **2.3.7(1)**).

(6) The following topics are dealt with in the text of this Part:

- Basic requirements and Compliance Criteria,
- Seismic Action,
- Analysis,
- Strength Verification,
- Detailing.

This Part also includes a special section on seismic isolation with provisions covering the application of this method of seismic protection to bridges.

(7) Annex G contains rules for the calculation of capacity design effects.

(8) Annex J contains rules regarding the variation of design properties of seismic isolator units and how such variation may be taken into account in design.

NOTE 1 Informative Annex A provides information for the probabilities of the reference seismic event and recommendations for the selection of the design seismic action during the construction phase.

NOTE 2 Informative Annex B provides information on the relationship between the displacement ductility and the curvature ductility of plastic hinges in concrete piers.

NOTE 3 Informative Annex C provides information for the estimation of the effective stiffness of reinforced concrete ductile members.

NOTE 4 Informative Annex D provides information for modelling and analysis for the spatial variability of earthquake ground motion.

NOTE 5 Informative Annex E gives information on probable material properties and plastic hinge deformation capacities for non-linear analyses.

NOTE 6 Informative Annex F gives information and guidance for the added mass of entrained water in immersed piers.

NOTE 7 Informative Annex H provides guidance and information for static non-linear analysis (pushover).

NOTE 8 Informative Annex JJ provides information on  $\lambda$ -factors for common isolator types.

NOTE 9 Informative Annex K contains tests requirements for validation of design properties of seismic isolator units.

### **1.1.2 Further parts of EN 1998**

See EN 1998-1:2004.

## **1.2 Normative References**

### **1.2.1 Use**

(1)P The following normative documents contain provisions, which through references in this text, constitute provisions of this European standard. For dated references, subsequent amendments to or revisions of any of these publications do not apply. However, parties to agreements based on this European standard are encouraged to investigate the possibility of applying the most recent editions of the normative documents indicated below. For undated references the latest edition of the normative document referred to applies (including amendments).

### **1.2.2 General reference standards**

EN 1998-1:2004, **1.2.1** applies.

### **1.2.3 Reference Codes and Standards**

EN 1998-1:2004, **1.2.2** applies.

### **1.2.4 Additional general and other reference standards for bridges**

EN 1990: Annex A2 Basis of structural design: Application for bridges

EN 1991-2:2003 Actions on structures: Traffic loads on bridges

EN 1992-2:2005	Design of concrete structures. Part 2 – Bridges
EN 1993-2:2005	Design of steel structures. Part 2 – Bridges
EN 1994-2:2005	Design of composite (steel-concrete) structures. Part 2 – Bridges
EN 1998-1:2004	Design of structures for earthquake resistance. General rules, seismic actions and rules for buildings
EN 1998-5:2004	Design of structures for earthquake resistance. Foundations, retaining structures and geotechnical aspects.
EN 1337-2:2000	Structural bearings – Part 2: Sliding elements
EN 1337-3:2005	Structural bearings – Part 3: Elastomeric bearings
prEN 15129:200X	Antiseismic Devices

### 1.3 Assumptions

(1) In addition to the general assumptions of EN 1990:2002, **1.3** the following assumption applies.

(2)P It is assumed that no change of the structure will take place during the construction phase or during the subsequent life of the structure, unless proper justification and verification is provided. Due to the specific nature of the seismic response this applies even in the case of changes that lead to an increase of the structural resistance of members.

### 1.4 Distinction between principles and application rules

(1) The rules of EN 1990:2002, **1.4** apply.

### 1.5 Definitions

#### 1.5.1 General

(1) For the purposes of this standard the following definitions are applicable.

#### 1.5.2 Terms common to all Eurocodes

(1) The terms and definitions of EN 1990:2002, **1.5** apply.

#### 1.5.3 Further terms used in EN 1998-2

##### **capacity design**

design procedure used when designing structures of ductile behaviour to ensure the hierarchy of strengths of the various structural components necessary for leading to the intended configuration of plastic hinges and for avoiding brittle failure modes



**ductile members**

members able to dissipate energy through the formation of plastic hinges

**ductile structure**

structure that under strong seismic motions can dissipate significant amounts of input energy through the formation of an intended configuration of plastic hinges or by other mechanisms

**limited ductile behaviour**

seismic behaviour of bridges, without significant dissipation of energy in plastic hinges under the design seismic action

**positive linkage**

connection implemented by seismic links

**seismic isolation**

provision of bridge structures with special isolating devices for the purpose of reducing the seismic response (forces and/or displacements)

**spatial variability (of seismic action)**

situation in which the ground motion at different supports of the bridge differs and, hence, the seismic action cannot be based on the characterisation of the motion at a single point

**seismic behaviour**

behaviour of the bridge under the design seismic event which, depending on the characteristics of the global force-displacement relationship of the structure, can be ductile or limited ductile/essentially elastic

**seismic links**

restrainers through which part or all of the seismic action may be transmitted. Used in combination with bearings, they may be provided with appropriate slack, so as to be activated only in the case when the design seismic displacement is exceeded

**minimum overlap length**

safety measure in the form of a minimum distance between the inner edge of the supported and the outer edge of the supporting member. The minimum overlap is intended to ensure that the function of the support is maintained under extreme seismic displacements

**design seismic displacement**

displacement induced by the design seismic actions.

**total design displacement in the seismic design situation**

displacement used to determine adequate clearances for the protection of critical or major structural members. It includes the design seismic displacement, the displacement due to the long term effect of the permanent and quasi-permanent actions and an appropriate fraction of the displacement due to thermal movements.

## 1.6 Symbols

### 1.6.1 General

(1) The symbols indicated in EN 1990:2002, **1.6** apply. For the material-dependent symbols, as well as for symbols not specifically related to earthquakes, the provisions of the relevant Eurocodes apply.

(2) Further symbols, used in connection with the seismic actions, are defined in the text where they occur, for ease of use. However, in addition, the most frequently occurring symbols in EN 1998-2 are listed and defined in the following subsections.

### 1.6.2 Further symbols used in Sections 2 and 3 of EN 1998-2

$d_E$	design seismic displacement (due only to the design seismic action)
$d_{Ec}$	seismic displacement determined from linear analysis
$d_G$	long term displacement due to the permanent and quasi-permanent actions
$d_g$	design ground displacement in accordance with EN 1998-1:2004, <b>3.2.2.4</b>
$d_i$	ground displacement of set B at support $i$
$d_{ri}$	ground displacement at support $i$ relative to reference support 0
$d_T$	displacement due to thermal movements
$d_u$	ultimate displacement
$d_y$	yield displacement
$A_{Ed}$	design seismic action
$F_{Rd}$	design value of resisting force to the earthquake action
$L_g$	distance beyond which the ground motion may be considered completely uncorrelated
$L_i$	distance of support $i$ from reference support 0
$L_{i-1,i}$	distance between consecutive supports $i-1$ and $i$
$R_i$	reaction force at the base of pier $i$
$S_a$	site-averaged response spectrum
$S_i$	site-dependent response spectrum
$T_{eff}$	effective period of the isolation system
$\gamma$	importance factor
$\Delta d_i$	ground displacement of intermediate support $i$ relative to adjacent supports $i-1$ and $i+1$
$\mu_d$	displacement ductility factor
$\psi_2$	combination factor for the quasi-permanent value of thermal action

**1.6.3 Further symbols used in Section 4 of EN 1998-2**

$d_a$	average of the displacements in the transverse direction of all pier tops under the transverse seismic action, or under the action of a transverse load of similar distribution
$d_i$	displacement of the $i$ -th nodal point
$d_m$	asymptotic value of the spectrum for the $m$ -th motion for long periods, expressed in terms of displacements
$e$	$e_a + e_d$
$e_a$	accidental mass eccentricity ( $= 0,03L$ , or $0,03B$ )
$e_d$	additional eccentricity reflecting the dynamic effect of simultaneous translational and torsional vibration ( $= 0,05L$ or $0,05B$ )
$e_o$	theoretical eccentricity
$g$	acceleration of gravity
$h$	depth of the cross-section in the direction of flexure of the plastic hinge
$k_m$	effect of the $m$ -th independent motion
$r_i$	required local force reduction factor at ductile member $i$
$r_{\min}$	minimum value of $r_i$
$r_{\max}$	maximum value of $r_i$
$A_{Ed}$	design seismic action
$A_{Ex}$	seismic action in direction $x$
$A_{Ey}$	seismic action in direction $y$
$A_{Ez}$	seismic action in direction $z$
$B$	width of the deck
$E$	probable maximum value of an action effect
$E_i$	response in mode $i$
$F$	horizontal force determined in accordance with the fundamental mode method
$G$	total effective weight of the structure, equal to the weight of the deck plus the weight of the top half of the piers
$G_i$	weight concentrated at the $i$ -th nodal point
$K$	stiffness of the system
$L$	total length of the continuous deck
$L_s$	distance from the plastic hinge to the point of zero moment
$M$	total mass
$M_{Ed,i}$	maximum value of design moment in the seismic design situation at the intended location of plastic hinge of ductile member $i$
$M_{Rd,i}$	design flexural resistance of the plastic hinge section of ductile member $i$
$M_t$	equivalent static moment about the vertical axis through the centre of mass of the deck

$Q_{k,l}$	characteristic value of traffic load
$R_d$	design value of resistance
$S_d(T)$	spectral acceleration of the design spectrum
$T$	period of the fundamental mode of vibration for the direction under consideration
$X$	horizontal longitudinal axis of the bridge
$Y$	horizontal transverse axis of the bridge
$Z$	vertical axis
$\alpha_s$	shear span ratio of the pier
$\Delta_d$	maximum difference of the displacements in the transverse direction of all pier tops under the transverse seismic action, or under the action of a transverse load of similar distribution
$\eta_k$	normalized axial force ( $= N_{Ed}/(A_c f_{ck})$ )
$\theta_{p,d}$	design value of plastic rotation capacity
$\theta_{p,E}$	plastic hinge rotation demand
$\xi$	viscous damping ratio
$\psi_{2,i}$	factor for quasi-permanent value of variable action $i$

#### 1.6.4 Further symbols used in Section 5 of EN 1998-2

$d_{Ed}$	relative transverse displacement of the ends of the ductile member under consideration
$f_{ck}$	characteristic value of concrete strength
$f_{ctd}$	design value of tensile strength of concrete
$f_{sd}$	reduced stress of reinforcement, for limitation of cracking
$f_{sy}$	design value of yield strength of the joint reinforcement
$z_b$	internal lever arm of the beam end sections
$z_c$	internal lever arm of the plastic hinge section of the column
$A_C (V_C, M_C, N_C)$	capacity design effects
$A_c$	area of the concrete section
$A_{Ed}$	design seismic action (seismic action alone)
$A_{Sd}$	action in the seismic design situation
$A_{sx}$	area of horizontal joint reinforcement
$A_{sz}$	area of vertical joint reinforcement
$E_d$	design value of action effect of in the seismic design situation
$G_k$	characteristic value of permanent load
$M_o$	overstrength moment

$M_{Ed}$	design moment in the seismic design situation
$M_{Rd}$	design value of flexural strength of the section
$N_{Ed}$	axial force in the seismic design situation
$N_{cG}$	axial force in the column under the permanent and the quasi-permanent actions in the seismic design situation
$N_{jz}$	vertical axial force in a joint
$Q_{1k}$	characteristic value of the traffic load
$Q_2$	quasi-permanent value of actions of long duration
$P_k$	characteristic value of prestressing after all losses
$R_d$	design value of the resistance of the section
$R_{df}$	design value of the maximum friction force of sliding bearing
$T_{Re}$	resultant force of the tensile reinforcement of the column
$V_{E,d}$	design value of shear force
$V_{jx}$	design value of horizontal shear of the joint
$V_{jz}$	design value of vertical shear of the joint
$V_{1bC}$	shear force of the beam adjacent to the tensile face of the column
$\gamma_M$	material partial factor
$\gamma_o$	overstrength factor
$\gamma_{of}$	magnification factor for friction due to ageing effects
$\gamma_{Bd}, \gamma_{Bd1}$	additional safety factor against brittle failure modes
$\rho_x$	ratio of horizontal reinforcement in joint
$\rho_y$	reinforcement ratio of closed stirrups in the transverse direction of the joint panel (orthogonal to the plane of action)
$\rho_z$	ratio of vertical reinforcement in joint
$\psi_{21}$	combination factor
$\Delta A_{sx}$	area of horizontal joint reinforcement placed outside joint body
$\Delta A_{sz}$	area of vertical joint reinforcement placed outside joint body

### 1.6.5 Further symbols used in Section 6 of EN 1998-2

$a_g$	design ground acceleration on type A ground (see EN 1998-1:2004, 3.2.2.2).
$b$	cross-sectional dimension of the concrete core perpendicular to the direction of the confinement under consideration, measured to the centre line of the perimeter hoop
$b_{min}$	smallest dimension of the concrete core
$d_{bL}$	diameter of longitudinal bar
$d_{cg}$	effective displacement due to the spatial variation of the seismic ground displacement

$d_{cs}$	effective seismic displacement of the support due to the deformation of the structure
$d_g$	design peak ground displacement as specified by EN 1998-1:2004, <b>3.2.2.4</b>
$f_t$	tensile strength
$f_y$	yield strength
$f_{ys}$	yield strength of the longitudinal reinforcement
$f_{yt}$	yield strength of the tie
$l_m$	minimum support length securing the safe transmission of the vertical reaction
$l_{ov}$	minimum overlap length
$s$	spacing of tie legs on centres
$s_L$	maximum (longitudinal) spacing
$s_T$	spacing of between hoop legs or supplementary cross ties on centres
$s_t$	transverse spacing
$v_g$	design ground velocity
$v_s$	shear wave velocity in the soil at small shear strains
$A_c$	area of the gross concrete section
$A_{cc}$	cross-sectional area of the confined concrete core of the section
$A_{sp}$	cross-sectional area of the spiral or hoop bar
$A_{sw}$	total cross-sectional area of hoops or ties in the one transverse direction of confinement
$A_t$	cross-sectional area of one tie leg
$D_i$	inside diameter
$D_{sp}$	diameter of the spiral or hoop bar
$E_d$	total earth pressure acting on the abutment under seismic conditions as per EN 1998-5: 2004
$F_{Rd}$	design resistance
$L_h$	design length of plastic hinges
$L_{eff}$	effective length of deck
$Q_d$	weight of the section of the deck linked to a pier or abutment, or the least of the weights of the two deck sections on either side of an intermediate separation joint
$S$	soil factor specified in EN 1998-1:2004, <b>3.2.2.2</b>
$T_C$	corner period of elastic spectrum as specified in EN 1998-1:2004, <b>3.2.2.2</b>
$\alpha_g$	design ground acceleration on type A ground
$\gamma$	importance factor
$\gamma_s$	free-field seismic shear deformation of the soil

$\delta$	parameter depending on the ratio $f/f_y$
$\mu_\phi$	required curvature ductility factor
$\sum A_s$	sum of the cross-sectional areas of the longitudinal bars restrained by the tie
$\rho_L$	ratio of the longitudinal reinforcement
$\rho_w$	transverse reinforcement ratio
$\omega_{wd}$	mechanical ratio of confinement reinforcement

### 1.6.6 Further symbols used in Section 7 and Annexes J, JJ and K of EN 1998-2

$a_g$	design ground acceleration on type A ground
$a_{g,R}$	reference peak ground acceleration on type A ground reference
$d$	design displacement
$d_b$	displacement of isolator
$d_{bd}$	design displacement of isolator corresponding to the design displacement of the isolating system $d_{cd}$
$d_{bi}$	displacement of isolator $i$
$d_{bi,a}$	increased design displacement of isolator $i$
$d_{bi,d}$	design displacement of isolator $i$
$d_{cd}$	design displacement of the isolating system
$d_{cf}$	design displacement of the isolating system resulting from the fundamental mode method
$d_{d,m}$	displacement of the stiffness centre derived from the analysis
$\langle A_i \rangle d_{G,i}$	offset displacement of isolator $i$ $\langle A_i \rangle$
$d_{id}$	displacement of the superstructure at the location of substructure and isolator $i$
$d_m$	displacement capacity of the isolating system
$d_{max}$	maximum displacement
$\langle A_i \rangle d_{m,i}$	maximum total displacement of each isolator unit $i$ $\langle A_i \rangle$
$d_n, d_p$	minimum negative and positive displacement in test respectively
$d_{rm}$	residual displacement of the isolating system
$d_y$	yield displacement
$e_x$	eccentricity in the longitudinal bridge direction
$r$	radius of gyration of the deck mass about vertical axis through its centre of mass
$\text{sign}(\dot{d}_b)$	sign of the velocity vector $\dot{d}_b$
$t_c$	total elastomer thickness
$v$	velocity of motion of a viscous isolator
$v_{max}$	maximum velocity of motion of a viscous isolator
$x_i, y_i$	co-ordinates of pier $i$ in plan

$A_b$	effective cross-sectional area of elastomeric bearing
$E_D$	dissipated energy per cycle at the design displacement of isolating system $d_{cd}$
$E_{Di}$	dissipated energy per cycle of isolator unit $i$ , at the design displacement of isolating system $d_{cd}$
$E_E$	design seismic forces
$E_{EA}$	seismic internal forces derived from the analysis
$F_{max}$	max force corresponding to the design displacement
$F_n, F_p$	minimum negative and maximum positive forces of test, respectively, for units with hysteretic or frictional behaviour, or negative and positive forces of test respectively corresponding to $d_n$ and $d_p$ , respectively, for units with viscoelastic behaviour
$F_y$	yield force under monotonic loading
$F_0$	force at zero displacement under cyclic loading
$G_b$	shear modulus of elastomeric bearing
$G_g$	apparent conventional shear modulus of elastomeric bearing in accordance with EN 1337-3:2005

HDRB High Damping Rubber Bearing

$H_i$	height of pier $i$
$K_{bi}$	effective stiffness of isolator unit $i$
$K_c$	elastic stiffness of bilinear hysteretic isolator under monotonic loading
$K_L$	stiffness of lead core of lead-rubber bearing
$K_p$	post elastic stiffness of bilinear hysteretic isolator
$K_{eff}$	effective stiffness of the isolation system in the principal horizontal direction under consideration, at a displacement equal to the design displacement $d_{cd}$
$K_{eff,i}$	composite stiffness of isolator units and the corresponding pier $i$
$K_{fi}$	rotation stiffness of foundation of pier $i$
$K_R$	stiffness of rubber of lead-rubber bearing
$K_{ri}$	rotation stiffness of foundation of pier $i$
$K_{si}$	displacement stiffness of shaft of pier $i$
$K_{ti}$	translation stiffness of foundation of pier $i$
$K_{xi}, K_{yi}$	effective composite stiffness of isolator unit and pier $i$

LRB Lead Rubber Bearing

$M_d$	mass of the superstructure
$N_{Sd}$	axial force through the isolator
PTFE	polytetrafluorethylene
$Q_G$	permanent axial load of isolator
$R_b$	radius of spherical sliding surface
$S$	soil factor of elastic spectrum in accordance with EN 1998-1:2004, <b>3.2.2.2</b>



$T_C, T_D$	corner periods of the elastic spectrum in accordance with 7.4.1(1)P and EN 1998-1:2004, 3.2.2.2
$T_{\text{eff}}$	effective period of the isolating system
$T_{\text{min,b}}$	minimum bearing temperature for seismic design
$V_d$	maximum shear force transferred through the isolation interface
$V_f$	maximum shear force estimated through the fundamental mode method
UBDP	Upper bound design properties of isolators
LBDP	Lower bound design properties of isolators
$\alpha_b$	exponent of velocity of viscous damper
$\gamma$	importance factor of the bridge
$\Delta F_{\text{Ed}}$	additional vertical load due to seismic overturning effects
$\Delta F_m$	force increase between displacements $d_m/2$ and $d_m$
$\mu_d$	dynamic friction coefficient
$\xi$	equivalent viscous damping ratio
$\xi_b$	contribution of isolators to effective damping
$\xi_{\text{eff}}$	effective damping of the isolation system
$\psi_{fi}$	combination factor

## 2 BASIC REQUIREMENTS AND COMPLIANCE CRITERIA

### 2.1 Design seismic action

(1)P The design philosophy of this Standard is to achieve with appropriate reliability the non-collapse requirement of **2.2.2** and of EN 1998-1:2004, **2.1(1)P**, for the design seismic action ( $A_{Ed}$ ).

(2)P Unless otherwise specified in this part, the elastic spectrum of the design seismic action in accordance with EN 1998-1:2004, **3.2.2.2**, **3.2.2.3** and **3.2.2.4** applies. For application of the equivalent linear method of **4.1.6** (using the behaviour factor  $q$ ) the spectrum shall be the design spectrum in accordance with EN 1998-1:2004, **3.2.2.5**.

(3)P The design seismic action,  $A_{Ed}$ , is expressed in terms of: (a) the reference seismic action,  $A_{EK}$ , associated with a reference probability of exceedance,  $P_{NCR}$ , in 50 years or a reference return period,  $T_{NCR}$ , (see EN 1998-1:2004, **2.1(1)P** and **3.2.1(3)**) and (b) the importance factor  $\gamma_I$  (see EN 1990: 2002 and EN 1998-1:2004, **2.1(2)P**, **2.1(3)P** and **(4)**) to take into account reliability differentiation:

$$A_{Ed} = \gamma_I A_{EK} \quad (2.1)$$

NOTE 1 The value to be ascribed to the reference return period,  $T_{NCR}$ , associated with the reference seismic action for use in a country, may be found in its National Annex. The recommended value is:  $T_{NCR} = 475$  years.

NOTE 2 Informative Annex A gives information on the reference seismic action and on the selection of the design seismic action during the construction phase.

(4)P Bridges shall be classified in importance classes, depending on the consequences of their failure for human life, on their importance for maintaining communications, especially in the immediate post-earthquake period, and on the economic consequences of collapse.

NOTE The definitions of the importance classes for bridges in a country may be found in its National Annex. The recommended classification is in three importance classes, as follows:

In general road and railway bridges are considered to belong to importance class II (average importance), with the exceptions noted below.

Importance class III comprises bridges of critical importance for maintaining communications, especially in the immediate post-earthquake period, bridges the failure of which is associated with a large number of probable fatalities and major bridges where a design life greater than normal is required.

A bridge may be classified to importance class I (less than average importance) when both of the following conditions are met.

- the bridge is not critical for communications, and
- the adoption of either the reference probability of exceedance,  $P_{NCR}$ , in 50 years for the design seismic action, or of the standard bridge design life of 50 years is not economically justified.

Importance classes I, II and III correspond roughly to consequences classes CC1, CC2 and CC3, respectively, defined in EN 1990:2002, **B3.1**.

(5)P The importance classes are characterised by different importance factors  $\gamma_I$  as described in **2.1(3)P** and in EN 1998-1:2004, **2.1(3)P**.

(6) The importance factor  $\gamma_I = 1,0$  is associated with a seismic action having the reference return period indicated in **2.1(3)P** and in EN 1998-1:2004, **3.2.1(3)**.

NOTE The values to be ascribed to  $\gamma_I$  for use in a country may be found in its National Annex. The values of  $\gamma_I$  may be different for the various seismic zones of the country, depending on the seismic hazard conditions and on public safety considerations (see NOTE to EN 1998-1:2004, **2.1(4)**). The recommended values of  $\gamma_I$  for importance classes I, and III are equal to 0,85, and 1,3, respectively.

## 2.2 Basic requirements

### 2.2.1 General

(1)P The design shall aim at fulfilling the following two basic requirements.

### 2.2.2 No-collapse (ultimate limit state)

(1)P After occurrence of the design seismic action, the bridge shall retain its structural integrity and adequate residual resistance, although at some parts of the bridge considerable damage may occur.

(2) Flexural yielding of specific sections (i.e. the formation of plastic hinges) is allowed to occur in the piers. When no seismic isolation is provided, such flexural yielding is in general necessary in regions of high seismicity, in order to reduce the design seismic action to a level corresponding to a reasonable increase of the additional construction cost, compared to a bridge not designed for earthquake resistance.

(3) The bridge deck should in general be designed to avoid damage, other than locally to secondary components such as expansion joints, continuity slabs (see **2.3.2.2(4)**) or parapets.

(4) When the design seismic action has a substantial probability of exceedance within the design life of the bridge, the design should aim at a damage tolerant structure. Parts of the bridge susceptible to damage by their contribution to energy dissipation under the design seismic action should be designed to enable the bridge to be used by emergency traffic, following the design seismic action, and to be easily repairable.

(5) When the design seismic action has a low probability of being exceeded within the design life of the bridge, the seismic action may be considered as an accidental action, in accordance with EN 1990:2002, **1.5.3.5** and **4.1.1(2)**. In such a case the requirements of **(3)** and **(4)** may be relaxed.

NOTE The National Annex may specify the conditions under which **(5)** will be applied, as well as the extent of the relevant relaxations of **(3)** and **(4)**. It is recommended that **(3)** and **(4)** are applicable when the reference return period  $T_{NCR}$  is approximately equal to 475 years.

### **2.2.3 Minimisation of damage (serviceability limit state)**

(1)P A seismic action with a high probability of occurrence may cause only minor damage to secondary components and to those parts of the bridge intended to contribute to energy dissipation. All other parts of the bridge should remain undamaged.

## **2.3 Compliance criteria**

### **2.3.1 General**

(1)P To conform to the basic requirements set forth in **2.2**, the design shall comply with the criteria outlined in the following Clauses. In general the criteria, while aiming explicitly at satisfying the no-collapse requirement (**2.2.2**), implicitly cover the damage minimisation requirement (**2.2.3**) as well.

(2) Compliance with the criteria set forth in this standard is deemed to satisfy all basic requirements of **2.2**.

(3)P The compliance criteria depend on the behaviour which is intended for the bridge under the design seismic action. This behaviour may be selected in accordance with **2.3.2**.

### **2.3.2 Intended seismic behaviour**

#### **2.3.2.1 General**

(1)P The bridge shall be designed so that its behaviour under the design seismic action is either ductile, or limited ductile/essentially elastic, depending on the seismicity of the site, on whether seismic isolation is adopted for its design, or any other constraints which may prevail. This behaviour (ductile or limited ductile) is characterised by the global force-displacement relationship of the structure, shown schematically in Figure 2.1 (see also Table 4.1).

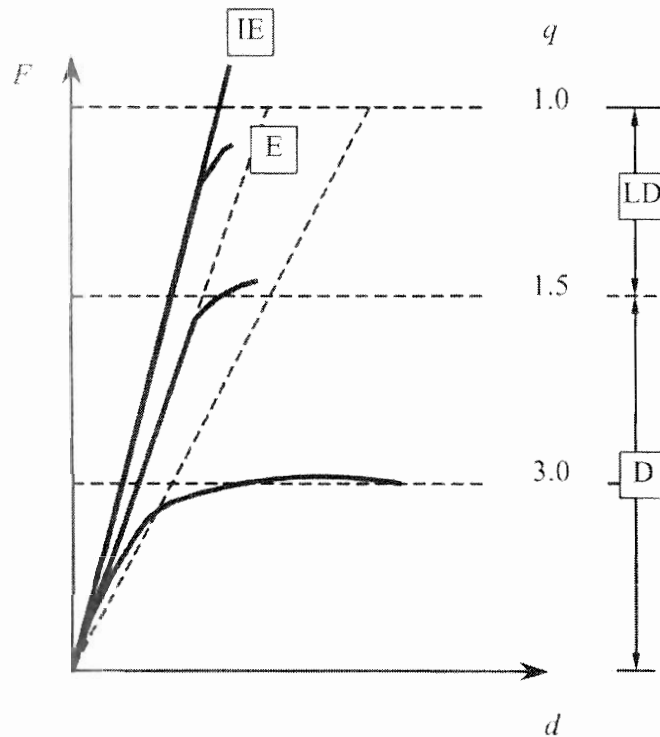
**Key**

- $q$  – Behaviour factor
- IE - Ideal elastic
- E - Essentially elastic
- LD - Limited ductile
- D - Ductile

**Figure 2.1: Seismic behaviour****2.3.2.2 Ductile behaviour**

(1) In regions of moderate to high seismicity it is usually preferable, both for economic and safety reasons, to design a bridge for ductile behaviour, i.e. to provide it with reliable means to dissipate a significant amount of the input energy under severe earthquakes. This is accomplished by providing for the formation of an intended configuration of flexural plastic hinges or by using isolating devices in accordance with Section 7. The part of this sub-clause that follows refers to ductile behaviour achieved by flexural plastic hinges.

(2)P Bridges of ductile behaviour shall be designed so that a dependably stable partial or full mechanism can develop in the structure through the formation of flexural plastic hinges. These hinges normally form in the piers and act as the primary energy dissipating components.

(3) As far as is reasonably practicable, the location of plastic hinges should be selected at points accessible for inspection and repair.

(4)P The bridge deck shall remain within the elastic range. However, formation of plastic hinges (in bending about the transverse axis) is allowed in flexible ductile concrete slabs providing top slab continuity between adjacent simply-supported precast concrete girder spans.

(5)P Plastic hinges shall not be formed in reinforced concrete sections where the normalised axial force  $\eta_k$  defined in 5.3(4) exceeds 0,6.

(6)P This standard does not contain rules for provision of ductility in prestressed or post-tensioned members. Consequently such members should be protected from formation of plastic hinges under the design seismic action.

(7) Flexural plastic hinges need not necessarily form in all piers. However the optimum post-elastic seismic behaviour of a bridge is achieved if plastic hinges develop approximately simultaneously in as many piers as possible.

(8) The capability of the structure to form flexural hinges is necessary, in order to ensure energy dissipation and consequently ductile behaviour (see 4.1.6(2)).

NOTE The deformation of bridges supported exclusively by simple low damping elastomeric bearings is predominantly elastic and does not lead in general to ductile behaviour (see 4.1.6(11)P).

(9) The global force-displacement relationship should exhibit a significant force plateau at yield and should ensure hysteretic energy dissipation over at least five inelastic deformation cycles (see Figures 2.1, 2.2 and 2.3).

NOTE Elastomeric bearings used over some supports in combination with monolithic support on other piers, may cause the resisting force to increase with increasing displacements, after plastic hinges have formed in the other supporting members. However, the rate of increase of the resisting force should be appreciably reduced after the formation of plastic hinges.

(10) Supporting members (piers or abutments) connected to the deck through sliding or flexible mountings (sliding bearings or flexible elastomeric bearings) should, in general, remain within the elastic range.

### 2.3.2.3 Limited ductile behaviour

(1) In structures with limited ductile behaviour, a yielding region with significant reduction in secant stiffness need not appear under the design seismic action. In terms of force-displacement characteristics, the formation of a force plateau is not required, while deviation from the ideal elastic behaviour provides some hysteretic energy dissipation. Such behaviour corresponds to a value of the behaviour factor  $q \leq 1,5$  and shall be referred to, in this Standard, as "limited ductile".

NOTE Values of  $q$  in the range  $1 \leq q \leq 1,5$  are mainly attributed to the inherent margin between design and probable strength in the seismic design situation.

(2) For bridges where the seismic response may be dominated by higher mode effects (e.g cable-stayed bridges), or where the detailing of plastic hinges for ductility may not be reliable (e.g. due to a high axial force or a low shear-span ratio), a behaviour factor of  $q = 1$  is recommended, corresponding to elastic behaviour.

### 2.3.3 Resistance verifications

(1)P In bridges designed for ductile behaviour the regions of plastic hinges shall be verified to have adequate flexural strength to resist the design seismic action effects as specified in 5.5. The shear resistance of the plastic hinges, as well as both the shear and flexural resistances of all other regions, shall be designed to resist the "capacity design effects" specified in 2.3.4 (see also 5.3).

(2) In bridges designed for limited ductile behaviour, all sections should be verified to have adequate strength to resist the design seismic action effects of 5.5 (see 5.6.2).

### 2.3.4 Capacity design

(1)P For bridges of ductile behaviour, capacity design shall be used to ensure that an appropriate hierarchy of resistance exists within the various structural components. This is to ensure that the intended configuration of plastic hinges will form and that brittle failure modes are avoided.

(2)P Fulfilment of (1)P shall be achieved by designing all members intended to remain elastic against all brittle modes of failure, using "capacity design effects". Such effects result from equilibrium conditions at the intended plastic mechanism, when all flexural hinges have developed an upper fractile of their flexural resistance (overstrength), as specified in 5.3.

(3) For bridges of limited ductile behaviour the application of the capacity design procedure is not required.

### 2.3.5 Provisions for ductility

#### 2.3.5.1 General requirement

(1)P The intended plastic hinges shall be provided with adequate ductility, to ensure the required overall global ductility of the structure.

NOTE The definitions of global and local ductilities, given in 2.3.5.2 and 2.3.5.3, are intended to provide the theoretical basis of ductile behaviour. In general they are not required for practical verification of ductility, which is effected in accordance with 2.3.5.4.

#### 2.3.5.2 Global ductility

(1) Referring to an equivalent one-degree-of-freedom system with an idealised elastic-perfectly plastic force-displacement relationship, as shown in Figure 2.2, the design value of the ductility factor of the structure (available displacement ductility factor) is defined as the ratio of the ultimate limit state displacement ( $d_u$ ) to the yield displacement ( $d_y$ ), both measured at the centre of mass: i.e.  $\mu_d = d_u/d_y$ .

(2) When an equivalent linear analysis is performed, the yield force of the global elastic-perfectly plastic force-displacement is assumed equal to the design value of the resisting force,  $F_{Rd}$ . The yield displacement defining the elastic branch is selected so as to best approximate the design force-displacement curve (for monotonic loading).

(3) The ultimate displacement  $d_u$  is defined as the maximum displacement satisfying the following condition. The structure should be capable of sustaining at least 5 full cycles of deformation to the ultimate displacement:

- without initiation of failure of the confining reinforcement for reinforced concrete sections, or local buckling effects for steel sections; and
- without a drop of the resisting force for steel ductile members or without a drop exceeding 20% of the ultimate resisting force for reinforced concrete ductile members (see Figure 2.3).

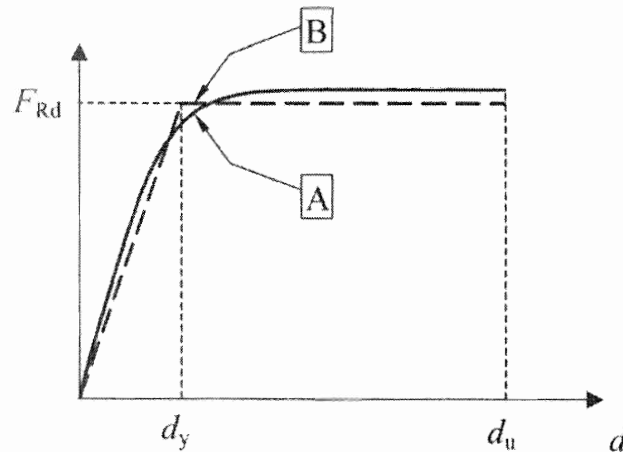

**Key**

A - Design

B - Elastoplastic

**Figure 2.2: Global force-displacement diagram (Monotonic loading)**

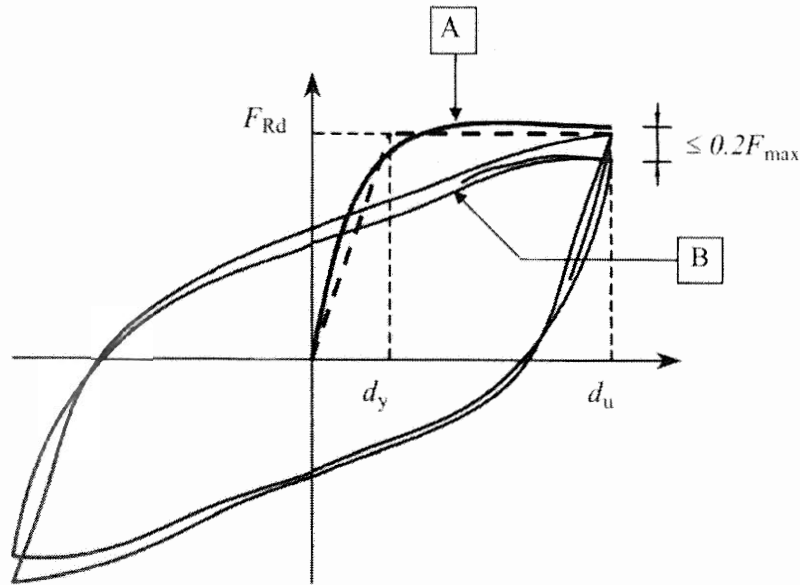

**Key**

A - Monotonic loading

B -5th cycle

**Figure 2.3: Force-displacement cycles (Reinforced concrete)****2.3.5.3 Local ductility at the plastic hinges**

(1) The global ductility of the structure depends on the available local ductility at the plastic hinges (see Figure 2.4). This can be expressed in terms of the curvature ductility factor of the cross-section:

$$\mu_{\Phi} = \Phi_u / \Phi_y \quad (2.2)$$

or, in terms of the chord rotation ductility factor at the end where the plastic hinge forms, that depends on the plastic rotation capacity,  $\theta_{p,u} = \theta_u - \theta_y$ , of the plastic hinge:

$$\mu_{\theta} = \theta_u / \theta_y = 1 + (\theta_u - \theta_y) / \theta_y = 1 + \theta_{p,u} / \theta_y \quad (2.3)$$

The chord rotation is measured over the length  $L$ , between the end section of the plastic hinge and the section of zero moment, as shown in Figure 2.4.

NOTE 1 For concrete members the relationship between  $\theta_p$ ,  $\Phi_u$ ,  $\Phi_y$ ,  $L$  and  $L_p$  is given by equation (E16b) in E.3.2 of Informative Annex E.

NOTE 2 The length of plastic hinges  $L_p$  for concrete members may be specified in the National Annex, as a function of the geometry and other characteristics of the member. The recommended expression is that given in Annex E.

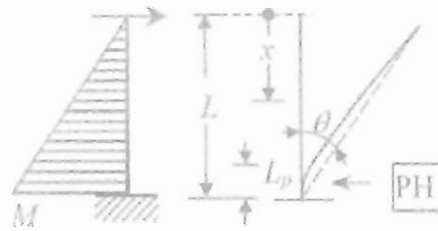

**Key**  
PH - Plastic hinge

**Figure 2.4: Chord rotation**  $\theta = \frac{1}{L} \int_0^L \Phi_x dx$

(2) In the above expressions the ultimate deformations should conform to the definitions in **2.3.5.2(3)**.

NOTE The relationship between curvature ductility of a plastic hinge and the global displacement ductility factor for a simple case is given in **Annex B**. That relationship is not intended for ductility verification.

#### 2.3.5.4 Ductility verification

(1)P Conformance to the Specific Rules specified in **Section 6** is deemed to ensure the availability of adequate local and global ductility.

(2)P When non-linear static or dynamic analysis is performed, chord rotation demands shall be checked against available rotation capacities of the plastic hinges (see **4.2.4.4**).

(3) For bridges of limited ductile behaviour the provisions of **6.5** should be applied.

#### 2.3.6 Connections - Control of displacements - Detailing

##### 2.3.6.1 Effective stiffness - Design seismic displacement

(1)P When equivalent linear analysis methods are used, the stiffness of each member shall be chosen corresponding to its secant stiffness under the maximum calculated stresses under the design seismic action. For members containing plastic hinges this corresponds to the secant stiffness at the theoretical yield point (See Figure 2.5).

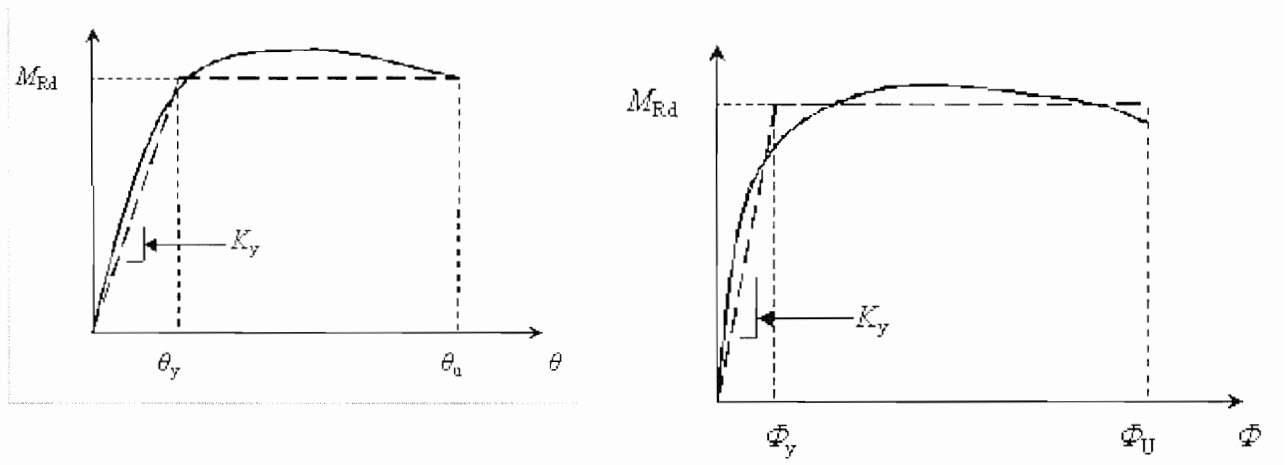

**Figure 2.5: Moment - deformation diagrams at plastic hinges**

Left: Moment-rotation relationship of plastic hinge for structural steel;

Right: Moment-curvature relationship of cross-section for reinforced concrete.

(2) For reinforced concrete members in bridges designed for ductile behaviour, and unless a more accurate method is used for its estimation, the effective flexural stiffness to be used in linear analysis (static or dynamic) for the design seismic action may be estimated as follows.

- For reinforced concrete piers, a value calculated on the basis of the secant stiffness at the theoretical yield point.
- For prestressed or reinforced concrete decks, the stiffness of the uncracked gross concrete sections.

NOTE **Annex C** gives guidance for the estimation of the effective stiffness of reinforced concrete members.

(3) In bridges designed for limited ductile behaviour, either the rules of (2) may be applied or the flexural stiffness of the uncracked gross concrete sections may be used for the entire structure.

(4) For both ductile and limited ductile bridges, the significant reduction of the torsional stiffness of concrete decks, in relation to the torsional stiffness of the uncracked deck, should be accounted for. Unless a more accurate calculation is made, the following fractions of the torsional stiffness of the uncracked gross section may be used:

- for open sections or slabs, the torsional stiffness may be ignored;
- for prestressed box sections, 50% of the uncracked gross section stiffness;
- for reinforced concrete box sections, 30% of the uncracked gross section stiffness.

(5) For both ductile and limited ductile bridges, displacements obtained from an analysis in accordance with (2) and (3) should be multiplied by the ratio of (a) the flexural stiffness of the member used in the analysis to (b) the value of flexural stiffness that corresponds to the level of stresses resulting from the analysis.

NOTE It is noted that in the case of equivalent linear analysis (see **4.1.6(1)P**) an overestimation of the effective stiffness leads to results which are on the safe side regarding the seismic action effects. In such a case, only the displacements need be corrected after the analysis, on the basis of the flexural stiffness that corresponds to the resulting level of moments. On the other hand, if the effective stiffness initially assumed is significantly lower than that corresponding to the stresses from the analysis, the analysis should be repeated using a better approximation of the effective stiffness.

(6)P If linear seismic analysis based on the design spectrum in accordance with EN 1998-1:2004, **3.2.2.5** is used, the design seismic displacements,  $d_E$ , shall be derived from the displacements,  $d_{Ee}$ , determined from such an analysis as follows:

$$d_E = \pm \eta \mu_d d_{Ee} \quad (2.4)$$

where

$\eta$  is the damping correction factor specified in EN 1998-1:2004, **3.2.2.2(3)** determined with the  $\xi$  values specified for damping in **4.1.3(1)**.

(7) When the displacements  $d_{Ee}$  are derived from a linear elastic analysis based on the elastic spectrum in accordance with EN 1998-1:2004, **3.2.2.2** ( $q = 1.0$ ), the design displacement,  $d_E$ , shall be taken as equal to  $d_{Ee}$ .

(8)P The displacement ductility factor shall be assumed as follows:

- when the fundamental period  $T$  in the considered horizontal direction is  $T \geq T_o = 1,25T_C$ , where  $T_C$  is the corner period defined in accordance with EN 1998-1:2004, **3.2.2.2**, then

$$\mu_d = q \quad (2.5)$$

- if  $T < T_o$ , then

$$\mu_d = (q - 1) \frac{T_o}{T} + 1 \leq 5q - 4 \quad (2.6)$$

where  $q$  is the value of the behaviour factor assumed in the analysis that results in the value of  $d_{Ee}$ .

NOTE Expression (2.6) provides a smooth transition between the “equal displacement” rule that is applicable for  $T \geq T_o$ , and the short period range (not typical to bridges) where the assumption of a low  $q$ -value is expedient. For very small periods ( $T < 0,033$  sec),  $q = 1$  should be assumed (see also **4.1.6(9)**), giving:  $\mu_d = 1$ .

(9)P When non-linear time-history analysis is used, the deformation characteristics of the yielding members shall approximate their actual post-elastic behaviour, both as far as the loading and unloading branches of the hysteresis loops are concerned, as well as potential degradation effects (see **4.2.4.4**).

### 2.3.6.2 Connections

(1)P Connections between supporting and supported members shall be designed in order to ensure structural integrity and avoid unseating under extreme seismic displacements.

(2) Unless otherwise specified in this Part, bearings, links and holding-down devices used for securing structural integrity, should be designed using capacity design effects (see 5.3, 6.6.2.1, 6.6.3.1 and 6.6.3.2).

(3) In new bridges appropriate overlap lengths should be provided between supporting and supported members at moveable connections, in order to avoid unseating (see 6.6.4).

(4) In retrofitting existing bridges as an alternative to the provision of overlap length, positive linkage between supporting and supported members may be used (see 6.6.1(3)P and 6.6.3.1(1)).

### 2.3.6.3 Control of displacements - Detailing

(1)P In addition to ensuring the required overall ductility, structural and non-structural detailing of the bridge and its components shall be provided to accommodate the displacements in the seismic design situation.

(2)P Clearances shall be provided for protection of critical or major structural members. Such clearances shall accommodate the total design value of the displacement in the seismic design situation,  $d_{Ed}$ , determined as follows:

$$d_{Ed} = d_E + d_G + \psi_2 d_T \quad (2.7)$$

where the following displacements shall be combined with the most unfavourable sign:

$d_E$  is the design seismic displacement in accordance with 2.3.6.1;

$d_G$  is the long term displacement due to the permanent and quasi-permanent actions (e.g. post-tensioning, shrinkage and creep for concrete decks);

$d_T$  is the displacement due to thermal movements;

$\psi_2$  is the combination factor for the quasi-permanent value of thermal action, in accordance with EN 1990:2002, Tables A2.1, A2.2 or A2.3.

Second order effects shall be taken into account in the calculation of the total design value of the displacement in the seismic design situation, when such effects are significant.

(3) The relative design seismic displacement,  $d_E$ , between two independent sections of a bridge may be estimated as the square root of the sum of squares of the values of the design seismic displacement calculated for each section in accordance with 2.3.6.1.

(4)P Large shock forces, caused by unpredictable impact between major structural members, shall be prevented by means of ductile/resilient members or special energy absorbing devices (buffers). Such members shall possess a slack at least equal to the total design value of the displacement in the seismic design situation,  $d_{Ed}$ .

(5) The detailing of non-critical structural components (e.g. deck movement joints and abutment back-walls), expected to be damaged due to the design seismic action, should cater for a predictable mode of damage, and provide for the possibility of permanent repair. Clearances should accommodate appropriate fractions of the design seismic displacement and of the thermal movement,  $p_E$  and  $p_T$ , respectively, after allowing for any long term creep and shrinkage effects, so that damage under frequent earthquakes is avoided. The appropriate values of such fractions may be chosen, based on a judgement of the cost-effectiveness of the measures taken to prevent damage.

NOTE 1 The value ascribed to  $p_E$  and  $p_T$  for use in a country in the absence of an explicit optimisation may be found in its National Annex. The recommended values are as follows:  $p_E = 0,4$  (for the design seismic displacement);  $p_T = 0,5$  (for the thermal movement).

NOTE 2 At joints of railway bridges, transverse differential displacement may have to be either avoided or limited to values appropriate for preventing derailment.

### 2.3.7 Simplified criteria

(1) In cases of low seismicity, simplified design criteria may be established.

NOTE 1: The selection of the categories of bridge, ground type and seismic zone in a country for which the provisions of low seismicity apply may be found in its National Annex. It is recommended that cases of low seismicity (and by consequence those of moderate to high seismicity) should be defined as recommended in the Note in EN 1998-1:2004, **3.2.1(4)**.

NOTE 2: Classification of bridges and simplified criteria for the seismic design pertaining to individual bridge classes in cases of low seismicity may be established by the National Annex. It is recommended that these simplified criteria are based on a limited ductile/essentially elastic seismic behaviour of the bridge, for which no special ductility requirements are necessary.

## 2.4 Conceptual design

(1) Consideration of the implications of the seismic action at the conceptual stage of the design of bridges is important, even in cases of low to moderate seismicity.

(2) In cases of low seismicity the type of intended seismic behaviour of the bridge (see **2.3.2**) should be decided. If a limited ductile (or essentially elastic) behaviour is selected, simplified criteria, in accordance with **2.3.7** may be applied.

(3) In cases of moderate or high seismicity, the selection of ductile behaviour is generally expedient. Its implementation, either by providing for the formation of a dependable plastic mechanism or by using seismic isolation and energy dissipation devices, should be decided. When a ductile behaviour is selected, **(4)** to **(8)** should be observed.

(4) The number of supporting members (piers and abutments) that will be used to resist the seismic forces in the longitudinal and transverse directions should be decided. In general bridges with continuous deck behave better under seismic conditions than those with many movement joints. The optimum post-elastic seismic behaviour is achieved if plastic hinges develop approximately simultaneously in as many piers as possible. However, the number of the piers that resist the seismic action may have to be less than the total number of piers, by using sliding or flexible mountings between the

deck and some piers in the longitudinal direction, to reduce the stresses arising from imposed deck deformations due to thermal actions, shrinkage and other non-seismic actions.

(5) A balance should be maintained between the strength and the flexibility requirements of the horizontal supports. High flexibility reduces the magnitude of lateral forces induced by the design seismic action but increases the movement at the joints and moveable bearings and may lead to high second order effects.

(6) In the case of bridges with a continuous deck and with transverse stiffness of the abutments and of the adjacent piers which is very high compared to that of the other piers (as may occur in steep-sided valleys), it may be preferable to use transversally sliding or elastomeric bearings over the short piers or the abutments to avoid unfavourable distribution of the transverse seismic action among the piers and the abutments such as that exemplified in Figure 2.6.

(7) The locations selected for energy dissipation should be chosen so as to ensure accessibility for inspection and repair. Such locations should be clearly indicated in the appropriate design documents.

(8) The location of areas of potential or expected seismic damage other than those in (7) should be identified and the difficulty of repairs should be minimised.

(9) In exceptionally long bridges, or in bridges crossing non-homogeneous soil formations, the number and location of intermediate movement joints should be decided.

(10) In bridges crossing potentially active tectonic faults, the probable discontinuity of the ground displacement should be estimated and accommodated either by adequate flexibility of the structure or by provision of suitable movement joints.

(11) The liquefaction potential of the foundation soil should be investigated in accordance with the relevant provisions of EN 1998-5:2004.

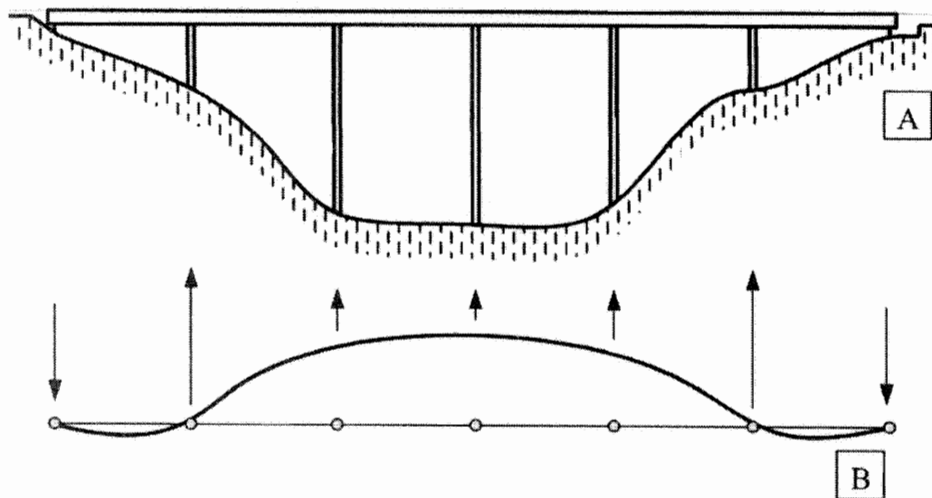

**Key**  
A – Elevation  
B - Plan

**Figure 2.6: Unfavourable distribution of transverse seismic action**



### 3 SEISMIC ACTION

#### 3.1 Definition of the seismic action

##### 3.1.1 General

(1)P The complexity of the model selected to describe the seismic action shall be appropriate to the relevant earthquake motion to be described and the importance of the structure and commensurate with the sophistication of the model used in the analysis of the bridge.

(2)P In this Section only the shaking transmitted by the ground to the structure is considered in the quantification of the seismic action. However, earthquakes can induce permanent displacements in soils arising from ground failure or fault rupture. These displacements may result in imposed deformations with severe consequences for bridges. This type of hazard shall be evaluated through specific studies. Its consequences shall be minimised by appropriate measures, such as selecting a suitable structural system. Tsunami effects are not treated in this Standard.

##### 3.1.2 Application of the components of the motion

(1)P In general only the three translational components of the seismic action need to be taken into account for the design of bridges. When the response spectrum method is applied, the bridge may be analysed separately for the translational components of the seismic action in the longitudinal, transverse and vertical directions. In this case the seismic action is represented by three one-component actions, one for each direction, quantified in accordance with 3.2. The action effects shall be combined in accordance with 4.2.1.4.

(2)P When non-linear time-history analysis is performed, the bridge shall be analysed under the simultaneous action of the different components.

(3) The seismic action is applied at the interface between the structure and the ground. If springs are used to represent the soil stiffness either in connection with spread footings or with deep foundations, such as piles, shafts (caissons), etc. (see EN 1998-5:2004), the motion is applied at the soil end of the springs.

#### 3.2 Quantification of the components

##### 3.2.1 General

(1)P Each component of the earthquake motion shall be quantified in terms of a response spectrum, or a time-history representation (mutually consistent) as set out in EN 1998-1:2004, Section 3, which also provides the basic definitions.

### 3.2.2 Site dependent elastic response spectrum

#### 3.2.2.1 Horizontal component

(1)P The horizontal component shall be in accordance with EN 1998-1:2004, **3.2.2.2**, depending on the ground type at the foundation of the supports of the bridge. When more than one ground types correspond to these supports, then **3.3** applies.

#### 3.2.2.2 Vertical component

(1)P When the vertical component of the seismic motion needs to be taken into account (see **4.1.7**), the site-dependent response spectrum of this component shall be taken in accordance with EN 1998-1:2004, **3.2.2.3**.

#### 3.2.2.3 Near source effects

(1)P Site-specific spectra considering near source effects shall be used, when the site is located within 10 km horizontally of a known active seismotectonic fault that may produce an event of Moment Magnitude higher than 6,5.

NOTE Unless the National Annex defines otherwise, it is recommended that a seismotectonic fault be considered to be active for the purposes of this requirement when there is an average historic slip rate of at least 1 mm/year and topographic evidence of seismic activity within the Holocene times (past 11000 years).

### 3.2.3 Time-history representation

(1)P When a non-linear time-history analysis is carried-out, at least three pairs of horizontal ground motion time-history components shall be used. The pairs should be selected from recorded events with magnitudes, source distances, and mechanisms consistent with those that define the design seismic action.

(2) When the required number of pairs of appropriate recorded ground motions is not available, appropriate modified recordings or simulated accelerograms may replace the missing recorded motions.

(3)P Consistency to the relevant 5% damped elastic response spectrum of the design seismic action shall be established by scaling the amplitude of motions as follows.

- a. For each earthquake consisting of a pair of horizontal motions, the SRSS spectrum shall be established by taking the square root of the sum of squares of the 5%-damped spectra of each component.
- b. The spectrum of the ensemble of earthquakes shall be formed by taking the average value of the SRSS spectra of the individual earthquakes of the previous step.
- c. The ensemble spectrum shall be scaled so that it is not lower than 1,3 times the 5%-damped elastic response spectrum of the design seismic action, in the period range between  $0,2T_1$  and  $1,5T_1$ , where  $T_1$  is the natural period of the fundamental mode of the structure in the case of a ductile bridge, or the effective period ( $T_{eff}$ ) of the isolation system in the case of a bridge with seismic isolation (see **7.2**).

d. The scaling factor derived from the previous step shall be applied to all individual seismic motion components.

(4) When the SRSS spectrum of the components of a recorded accelerogram gives accelerations the ratio of which to the corresponding values of the elastic response spectrum of the design seismic action shows large variation in the period range in (3)Pc, modification of the recorded accelerogram may be carried out, so that the SRSS spectrum of the modified components is in closer agreement with the elastic response spectrum of the design seismic action.

(5)P The components of each pair of time-histories shall be applied simultaneously.

(6) When three component ground motion time-history recordings are used for non-linear time-history analysis, scaling of the horizontal pairs of components may be carried out in accordance with (3)P, independently from the scaling of the vertical components. The latter shall be effected so that the average of the relevant spectra of the ensemble is not lower by more than 10% of the 5% damped elastic response spectrum of the vertical design seismic action in the period range between  $0,2T_v$  and  $1,5T_v$ , where  $T_v$  is the period of the lowest mode where the response to the vertical component prevails over the response to the horizontal components (e.g. in terms of participating mass).

(7) The use of pairs of horizontal ground motion recordings in combination with vertical recordings of different seismic motions, consistent with the requirements of (1)P above, is also allowed. The independent scaling of the pairs of horizontal recordings and of the vertical recordings shall be carried out as in (6).

(8) Modification of the recorded vertical component in (6) and (7) is permitted using the method specified in (4).

### 3.2.4 Site dependent design spectrum for linear analysis

(1)P Both ductile and limited ductile structures shall be designed by performing linear analysis using a reduced response spectrum, called design spectrum, as specified by EN 1998-1:2004, 3.2.2.5.

### 3.3 Spatial variability of the seismic action

(1)P For bridge sections with a continuous deck the spatial variability shall be considered when one or both of the following two conditions hold.

- Soil properties along the bridge vary to the extent that more than one ground types (as specified in EN 1998-1:2004, 3.1.1) correspond to the supports of the bridge deck.
- Soil properties along the bridge are approximately uniform, but the length of the continuous deck exceeds an appropriate limiting length,  $L_{lim}$ .

NOTE The value ascribed to  $L_{lim}$  for use in a country may be found in its National Annex. The recommended value is:  $L_{lim} = L_g/1.5$  where the length  $L_g$  is defined in (6) below.

(2)P The model describing spatial variability should account, even if only in a simplified way, for the propagative character of the seismic waves, as well as for the progressive loss of correlation between motions at different locations due to the random

non homogeneity of the soil, involving complex reflections and refractions of the waves. The model should also account, even if only in a simplified way, for the further increase in loss of correlation due to differences in the mechanical properties of the soil along the bridge, which also modify the frequency content from one support to the other.

NOTE Models of the spatial variability of the earthquake motions and appropriate methods of analysis are presented in informative Annex D.

(3) Unless a more accurate evaluation is made, the simplified method specified in the paragraphs (4) to (7) may be used.

(4) The inertia response should be accounted for by one of the methods specified in Section 4 (see 4.2.1, 4.2.3 and 4.2.4) using a single input seismic action for the entire structure (e.g. a single response spectrum or corresponding accelerogram sets), corresponding to the most severe ground type underneath the bridge supports.

(5) The spatial variation of the seismic action may be estimated by pseudo-static effects of appropriate displacement sets, imposed at the foundation of the supports of the bridge deck. These sets should reflect probable configurations of the spatial variability of the seismic motion at free field and should be selected so as to induce maximum values of the seismic action effect under investigation.

(6) The requirements in (5) are deemed to be satisfied, by imposing each of the following two sets of horizontal displacements, applied separately, in each horizontal direction of the analysis, on the relevant support foundations or on the soil end of the relevant spring representing the soil stiffness. The effects of the two sets need not be combined.

a. Set A

Set A consists of relative displacements:

$$d_{ri} = \varepsilon_r L_i \leq d_g \sqrt{2}$$

$$\text{with } \varepsilon_r = \frac{d_g \sqrt{2}}{L_g}$$

applied simultaneously with the same sign (+ or -) to all supports of the bridge ( $1$  to  $n$ ) in the horizontal direction considered (see Figure 3.1).

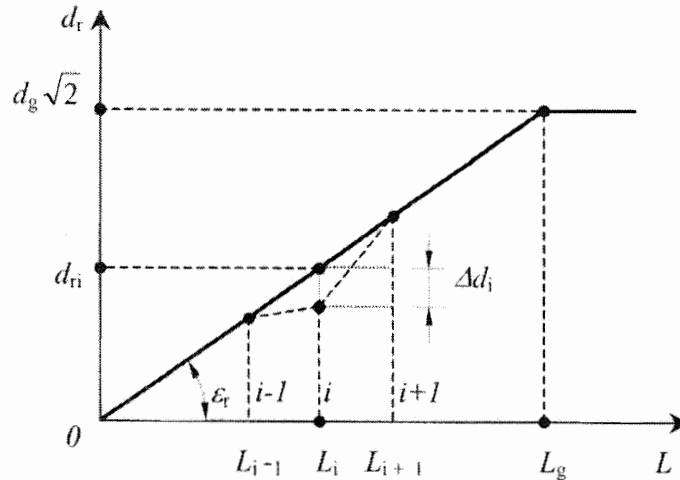

Figure 3.1 : Displacement Set A

where:

- $d_g$  is the design ground displacement corresponding to the ground type of support  $i$ , in accordance with EN 1998-1:2004, 3.2.2.4;
- $L_i$  is the distance (projection on the horizontal plane) of support  $i$  from a reference support  $i = 0$ , that may be conveniently selected at one of the end supports;
- $L_g$  is the distance beyond which the ground motions may be considered as completely uncorrelated.

NOTE 1: The value ascribed to  $L_g$  for use in a country may be found in its National Annex. The recommended value is given in Table 3.1N, depending on the ground type:

Table 3.1N: distance beyond which ground motions may be considered uncorrelated

Ground Type	A	B	C	D	E
$L_g$ (m)	600	500	400	300	500

b. Set B

Set B covers the influence of ground displacements occurring in opposite directions at adjacent piers. This is accounted for by assuming displacements  $\Delta d_i$  of any intermediate support  $i$  ( $>1$ ) relative to its adjacent supports  $i-1$  and  $i+1$  considered undisplaced (see Figure 3.1).

$$\Delta d_i = \pm \beta_r \epsilon_r L_{av,i}$$

where:

- $L_{av,i}$  is the average of the distances  $L_{i-1,i}$  and  $L_{i,i+1}$  of intermediate support  $i$  to its adjacent supports  $i-1$  and  $i+1$  respectively. For the end supports ( $0$  and  $n$ )  $L_{av,0} = L_{01}$  and  $L_{av,n} = L_{n-1,n}$ ;
- $\beta_r$  is a factor accounting for the magnitude of ground displacements occurring in opposite direction at adjacent supports.

NOTE 2: The value ascribed to  $\beta_r$  for use in a country may be found in its National Annex. The recommended value is:

$\beta_r = 0.5$  when all three supports have the same ground type

$\beta_r = 1.0$  when the ground type at one of the supports is different than at the other two.

$\varepsilon_r$  is as defined for set A above. If a change of ground type appears between two supports, the maximum value of  $\varepsilon_r$  should be used.

Set B consists of the following configuration of imposed absolute displacements with opposed sign at adjacent supports  $i$  and  $i+1$ , for  $i = 0$  to  $n-1$  (see Figure 3.2).

$$d_i = \pm \Delta d_i / 2$$

$$d_{i+1} = \pm \Delta d_{i+1} / 2$$

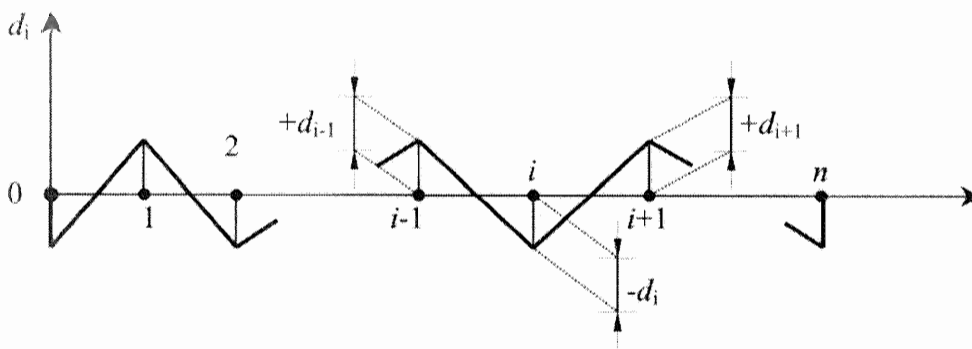

**Figure 3.2 : Displacement Set B**

(7)P In each horizontal direction the most severe effects resulting from the pseudo static analyses of (5) and (6) shall be combined with the relevant effects of the inertia response of (4), by using the SSRS rule (square root of the sum of squares). The result of this combination constitutes the effects of the analysis in the direction considered. For the combination of the effects of the different components of seismic action, the rules of 4.2.1.4 are applicable.

(8) When time-history analysis is performed the seismic motions applied at each support should reflect with sufficient reliability the probable spatial variability of the seismic action.

NOTE Guidance for generating samples of seismic motion reflecting the probable spatial variability is given in D.2 of Informative Annex D.

## 4 ANALYSIS

### 4.1 Modelling

#### 4.1.1 Dynamic degrees of freedom

(1)P The model of the bridge and the selection of the dynamic degrees of freedom shall represent the distribution of stiffness and mass so that all significant deformation modes and inertia forces are activated under the design seismic excitation.

(2) It is sufficient, in certain cases, to use two separate models in the analysis, one for modelling the response in the longitudinal direction of the bridge, and the other for the transverse direction. The cases when it is necessary to consider the vertical component of the seismic action are defined in **4.1.7**.

#### 4.1.2 Masses

(1)P The mean values of the permanent masses and the quasi-permanent values of the masses corresponding to the variable actions shall be considered.

(2) Distributed masses may be lumped at nodes in accordance with the selected degrees of freedom.

(3)P For design purposes the mean values of the permanent actions shall be taken equal to their characteristic values.

(4)P The quasi-permanent values of variable actions shall be taken as equal to  $\psi_{2,1}Q_{k,1}$  where  $Q_{k,1}$  is the characteristic value of traffic load.

NOTE The value ascribed to:  $\psi_{2,1}$  for use in a country may be found in its National Annex. The recommended values are:

Bridges with normal traffic and footbridges. In general and in accordance with the recommendation of EN 1990:2002, **Annex A2**,  $\psi_{2,1}=0$ .

Bridges with severe traffic and for the UDL system of Model 1 (LM1)

Road bridges  $\psi_{2,1} = 0,2;$

Railway bridges  $\psi_{2,1} = 0,3.$

Road bridges with severe traffic conditions may be considered as applying to motorways and other roads of national importance. Railway bridges with severe traffic conditions may be considered as applying to inter-city rail links and high speed railways.

When using  $Q_{k,1}$ , the adjustment factors  $\alpha_Q$  and  $\alpha_q$  should be applied in accordance with EN 1991-2:2003

(5) When the piers are immersed in water, and unless a more accurate assessment of the hydrodynamic interaction is made, this effect may be estimated by taking into account an added mass of entrained water acting in the horizontal directions per unit length of the immersed pier. The hydrodynamic influence on the vertical seismic action may be omitted.

NOTE Informative **Annex F** gives a procedure for the calculation of the added mass of entrained water in the horizontal directions, for immersed piers.

#### 4.1.3 Damping of the structure and stiffness of members

(1) When response spectrum analysis is used, the following values of equivalent viscous damping ratio  $\xi$  may be assumed, on the basis of the material of the members where the larger part of the deformation energy is dissipated during the seismic response. In general this will occur in the piers.

Welded steel	0,02
Bolted steel	0,04
Reinforced concrete	0,05
Prestressed concrete	0,02

NOTE When the structure comprises several components  $i$  with different viscous damping ratios,  $\xi_i$ , the effective viscous damping of the structure  $\xi_{\text{eff}}$  may be estimated as:

$$\xi_{\text{eff}} = \frac{\sum \xi_i E_{di}}{\sum E_{di}}$$

where  $E_{di}$  is the deformation energy induced in component  $i$  by the seismic action. Effective damping ratios may be conveniently estimated separately for each eigenmode, on the basis of the relevant value of  $E_{di}$ .

(2) Member stiffness may be estimated in accordance with **2.3.6.1**.

(3) In concrete decks consisting of precast concrete beams and cast in-situ slabs, continuity slabs (see **2.3.2.2(4)**) should be included in the model of seismic analysis, taking into account their eccentricity relative to the deck axis and a reduced value of their flexural stiffness. Unless this stiffness is estimated on the basis of the rotation of the relevant plastic hinges, a value of 25% of the flexural stiffness of the uncracked gross concrete section may be used.

(4) For second order effects **2.4 (5)** and **5.4 (1)** apply. Significant second order effects may occur in bridges with slender piers and in special bridges, like arch and cable-stayed bridges.

#### 4.1.4 Modelling of the soil

(1)P For the seismic analysis of the global system, the supporting members which transmit the seismic action from the soil to the deck shall, in general, be assumed as fixed relative to the foundation soil (see **3.1.2(3)**). Soil-structure interaction effects may be considered in accordance with EN 1998-5:2004, using appropriate impedances or appropriately defined soil springs.

(2) Soil-structure interaction effects should always be accounted for in piers where, under the action of a unit horizontal load in a given direction at the top of the pier, the soil flexibility contributes more than 20% of the total displacement at the top of the pier.



(3) Effects of soil-structure interaction on piles or shafts (caissons) shall be determined in accordance with EN 1998-5:2004, 5.4.2, taking into account the provisions of 6.4.2.

(4) In cases in which it is difficult to estimate reliably the mechanical properties of the soil, the analysis should be carried out using the estimated probable highest and lowest values. High estimates of soil stiffness should be used for calculating the internal forces and low estimates for calculating the displacements of the bridge.

#### 4.1.5 Torsional effects

(1)P Torsional motions of the bridge about a vertical axis shall be considered only in skewed bridges (skew angle  $\varphi > 20^\circ$ ) and bridges with a ratio  $B/L > 2,0$ .

NOTE Such bridges tend to rotate about the vertical axis, even when the centre of mass theoretically coincides with the centre of stiffness. ( $L$  is the total length of the continuous deck and  $B$  is the width of the deck).

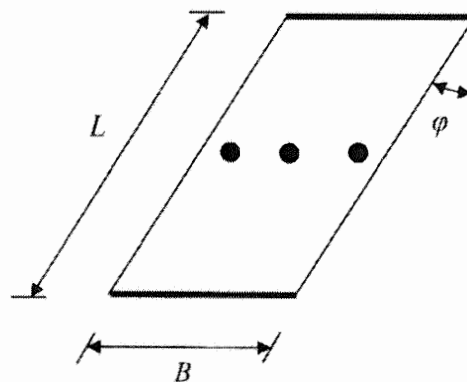

Figure 4.1: Skewed bridge

(2) Highly skewed bridges ( $\varphi > 45^\circ$ ) should in general be avoided in high seismicity regions. If this is not possible, and the bridge is supported on the abutments through bearings, the actual horizontal stiffness of the bearings should be accurately modelled, taking into account the concentration of vertical reactions near the obtuse angles. Alternatively, an increased accidental eccentricity may be used.

(3)P When using the Fundamental Mode Method (see 4.2.2) for the design of skewed bridges, the following equivalent static moment shall be considered to act about the vertical axis at the centre of gravity of the deck:

$$M_t = \pm F e \quad (4.1)$$

where:

$F$  is the horizontal force determined in accordance with expression (4.12);

$$e = e_a + e_d$$

$e_a = 0,03L$  or  $0,03B$  is the accidental eccentricity of the mass; and

$e_d = 0,05L$  or  $0,05B$  is an additional eccentricity reflecting the dynamic effect of simultaneous translational and torsional vibration.

For the calculation of  $e_a$  and  $e_d$  the dimension  $L$  or  $B$  transverse to the direction of excitation shall be used.

(4) When using a Full Dynamic Model (space model), the dynamic part of the torsional excitation is taken into account if the centre of mass is displaced by the accidental eccentricity  $e_a$  in the most unfavourable direction and sense. However, the torsional effects may also be estimated using the static torsional moment of expression (4.1).

(5)P The torsional resistance of a bridge structure shall not rely on the torsional rigidity of a single pier. In single span bridges the bearings shall be designed to resist the torsional effects.

#### 4.1.6 Behaviour factors for linear analysis

(1)P The reference procedure of the present standard is a response spectrum analysis for the design spectrum defined in EN 1998-1:2004, **3.2.2.5** (see **3.2.4(1)**). The behaviour factor is defined globally for the entire structure and reflects its ductility capacity, i.e. the capability of the ductile members to withstand, with acceptable damage but without failure, seismic actions in the post-elastic range. The available levels of ductility are specified in **2.3.2**. The capability of ductile members to develop flexural plastic hinges is an essential requirement for the application of the values of the behaviour factor  $q$  specified in Table 4.1 for ductile behaviour.

NOTE The linear analysis method, using sufficiently conservative global force reduction factors (behaviour factors as defined by Table 4.1), is generally considered to be a reasonable compromise between the uncertainties intrinsic to the seismic problem and the relevant admissible errors on the one hand and the required effort for the analysis and design on the other.

(2) This required capability of ductile members to develop flexural plastic hinges is deemed to be ensured when the detailing rules of Section **6** are followed and capacity design in accordance with **5.3** is performed.

(3)P The maximum values of the behaviour factor  $q$  which may be used for the two horizontal seismic components are specified in Table 4.1, depending on the post-elastic behaviour of the ductile members where the main energy dissipation takes place. If a bridge has various types of ductile members, the behaviour factor  $q$  corresponding to the type-group with the major contribution to the seismic resistance shall be used. Different values of the behaviour factor  $q$  may be used in each of the two horizontal directions.

NOTE Use of behaviour factor values less than the maximum allowable specified in Table 4.1 will normally lead to reduced ductility demands, implying in general a reduction of potential damage. Such a use is therefore at the discretion of the designer and the owner.

Table 4.1: Maximum values of the behaviour factor  $q$ 

Type of Ductile Members	Seismic Behaviour	
	Limited Ductile	Ductile
Reinforced concrete piers:		
Vertical piers in bending	1,5	3,5 $\lambda(\alpha_s)$
Inclined struts in bending	1,2	2,1 $\lambda(\alpha_s)$
Steel Piers:		
Vertical piers in bending	1,5	3,5
Inclined struts in bending	1,2	2,0
Piers with normal bracing	1,5	2,5
Piers with eccentric bracing	-	3,5
Abutments rigidly connected to the deck:		
In general	1,5	1,5
Locked-in structures (see. 4.1.6(9), (10))	1,0	1,0
Arches	1,2	2,0
<p>* <math>\alpha_s = L_s/h</math> is the shear span ratio of the pier, where <math>L_s</math> is the distance from the plastic hinge to the point of zero moment and <math>h</math> is the depth of the cross-section in the direction of flexure of the plastic hinge.</p> <p>For <math>\alpha_s \geq 3</math>      <math>\lambda(\alpha_s) = 1,0</math></p> <p><math>3 &gt; \alpha_s \geq 1,0</math>      <math>\lambda(\alpha_s) = \sqrt{\frac{\alpha_s}{3}}</math></p>		

NOTE In piers of rectangular shape, when under the seismic action in the global direction under consideration, the compression zone has triangular shape, the minimum of the values of  $\alpha_s$ , corresponding to the two sides of the section, should be used.

(4) For all bridges with regular seismic behaviour as specified in 4.1.8, the values of the  $q$ -factor specified in Table 4.1 for Ductile Behaviour may be used without any special verification of the available ductility, provided that the detailing requirements specified in Section 6 are met. When only the requirements specified in 6.5 are met, the values of the  $q$ -factor specified in Table 4.1 for Limited Ductile Behaviour may be used without any special verification of the available ductility, regardless of the regularity or irregularity of the bridge.

(5)P For reinforced concrete ductile members the values of  $q$ -factors specified in Table 4.1 are valid when the normalised axial force  $\eta_k$  defined in 5.3(4) does not exceed 0,30. If  $0,30 < \eta_k \leq 0,60$  even in a single ductile member, the value of the behaviour factor shall be reduced to:

$$q_r = q - \frac{\eta_k - 0,3}{0,3}(q - 1) \geq 1,0 \quad (4.2)$$

A value for  $q_r = 1,0$  (elastic behaviour) should be used for bridges in which the seismic force resisting system contains members with  $\eta_k \geq 0,6$ .

(6) The values of the  $q$ -factor for Ductile Behaviour specified in Table 4.1 may be used only if the locations of all the relevant plastic hinges are accessible for inspection and repair. Otherwise, the values of Table 4.1 shall be multiplied by 0,6; however, final  $q$ -values less than 1,0 need not be used.

NOTE The term “accessible”, as used in the paragraph above, has the meaning of “accessible even with reasonable difficulty”. The foot of a pier shaft located in backfill, even at substantial depth, is considered to be “accessible”. On the contrary, the foot of a pier shaft immersed in deep water, or the heads of piles beneath a large pile cap, should not be considered as “accessible”.

(7) When energy dissipation is intended to occur at plastic hinges located in piles designed for ductile behaviour, and at points which are not accessible, the final  $q$ -value to be used need not be less than 2,1 for vertical piles and 1,5 for inclined piles (see also EN 1998-5:2004, **5.4.2(5)**).

(8) Subclause **2.3.2.2(4)P** applies for plastic hinge formation in the deck.

NOTE The potential formation of plastic hinges in secondary deck members (continuity slabs) is allowed in this case, but should not be relied upon to increase the value of  $q$ .

(9) Bridge structures the mass of which essentially follows the horizontal seismic motion of the ground (“locked-in” structures) do not experience significant amplification of the horizontal ground acceleration. Such structures are characterised by a very low value of the natural period in the horizontal directions ( $T \leq 0,03$  s). The inertial response of these structures in the horizontal directions may be assessed by calculating the horizontal inertia forces directly from the design seismic ground acceleration and  $q = 1$ . Abutments flexibly connected to the deck belong to this category.

(10) Bridge structures consisting of an essentially horizontal deck rigidly connected to both abutments (either monolithically or through fixed bearings or links), may be considered to belong to the category of **(9)** irrespective of the value of the natural period, if the abutments are embedded in stiff natural soil formations over at least 80 % of their lateral area. If these conditions are not met, then the interaction with the soil at the abutments should be included in the model, using realistic soil stiffness parameters. If  $T > 0,03$  s, then the design spectrum defined in EN 1998-1:2004, **3.2.2.5** should be used with  $q = 1,50$ .

(11)P When the main part of the design seismic action is resisted by elastomeric bearings, the flexibility of the bearings leads to a practically elastic behaviour of the system. Such bridges shall be designed in accordance with Section 7.

NOTE: In general no plastic hinges will develop in piers which are flexibly connected to the deck in the direction considered. A similar situation will occur in individual piers with very low stiffness in comparison to the other piers (see **2.3.2.2(7)** and Note under **(9)**). Such members have negligible contribution in resisting the seismic actions and therefore do not affect the value of the  $q$ -factor (see **4.1.6(3)P**).

(12)P The behaviour factor for the analysis in the vertical direction shall always be taken as equal to 1,0.

#### 4.1.7 Vertical component of the seismic action

(1) The effects of the vertical seismic component on the piers may be omitted in cases of low and moderate seismicity. In zones of high seismicity these effects need only be taken into account if the piers are subjected to high bending stresses due to vertical permanent actions of the deck, or when the bridge is located within 5 km of an active seismotectonic fault, with the vertical seismic action determined in accordance with 3.2.2.3

(2)P The effects of the vertical seismic component acting in the upward direction on prestressed concrete decks, shall be always taken into account.

(3)P The effects of the vertical seismic component on bearings and links shall always be taken into account.

(4) The estimation of the effects of the vertical component may be carried out using the Fundamental Mode Method and the Flexible Deck Model (see 4.2.2.4).

#### 4.1.8 Regular and irregular seismic behaviour of ductile bridges

(1) Designating by  $M_{Ed,i}$  the maximum value of design moment at the intended plastic hinge location of ductile member  $i$  as derived from the analysis for the seismic design situation and by  $M_{Rd,i}$  the design flexural resistance of the same section with its actual reinforcement under the concurrent action of the non-seismic action effects in the seismic design situation, then the local force reduction factor  $r_i$  associated with member  $i$ , under the specific seismic action is defined as:

$$r_i = q \frac{M_{Ed,i}}{M_{Rd,i}} \quad (4.3)$$

Note 1 Since  $M_{Ed,i} \leq M_{Rd,i}$ , it follows that  $r_i \leq q$

Note 2 When in a regular bridge the maximum value of  $r_i$  among all ductile members,  $r_{max}$ , is substantially lower than  $q$ , the design cannot fully exploit the allowable maximum  $q$ -values. When  $r_{max} = 1,0$  the bridge responds elastically to the design earthquake considered.

(2)P A bridge shall be considered to have regular seismic behaviour in the considered horizontal direction, when the following condition is satisfied

$$\rho = \frac{r_{max}}{r_{min}} \leq \rho_o \quad (4.4)$$

where:

$r_{min}$  is the minimum value of  $r_i$  and

$r_{max}$  is the maximum value of  $r_i$  among all ductile members  $i$ , and;

$\rho_o$  is a limit value selected so as to ensure that sequential yielding of the ductile members will not cause unacceptably high ductility demands on one member.

NOTE The value ascribed to  $\rho_o$  for use in a country may be found in its National Annex. The recommended value is  $\rho_o = 2,0$ .

(3) One or more ductile members (piers) may be exempted from the above calculation of  $r_{\min}$  and  $r_{\max}$ , if their total shear contribution does not exceed 20% of the total seismic shear in the considered horizontal direction.

(4)P Bridges that do not conform to expression (4.4), shall be considered to have irregular seismic behaviour, in the considered horizontal direction. Such bridges shall either be designed using a reduced  $q$ -value:

$$q_r = q \frac{\rho_o}{\rho} \geq 1,0 \quad (4.5)$$

or shall be designed based on results of non-linear analysis in accordance with **4.1.9**.

#### **4.1.9 Non-linear analysis of irregular bridges**

(1) In bridges of irregular seismic behaviour, the sequential yielding of the ductile members (piers) may cause substantial deviations of the results of the equivalent linear analysis performed with the assumption of a global force reduction factor  $q$  (behaviour factor) from those of the non-linear response of the bridge structure. The deviations are due mainly to the following effects.

- The plastic hinges which appear first usually develop the maximum post-elastic strains, which may lead to concentration of unacceptably high ductility demands in these hinges;
- Following the formation of the first plastic hinges (normally in the stiffer members), the distribution of stiffnesses and hence of forces may change from that predicted by the equivalent linear analysis. This may lead to a substantial change in the assumed pattern of plastic hinges.

(2) In general the realistic response of irregular bridges under the design seismic action may be estimated by means of a dynamic non-linear time-history analysis, performed in accordance with **4.2.4**.

(3) An approximation of the non-linear response may also be obtained by a combination of an equivalent linear analysis with a non-linear static analysis (pushover analysis) in accordance with **4.2.5**.

### **4.2 Methods of analysis**

#### **4.2.1 Linear dynamic analysis - Response spectrum method**

##### **4.2.1.1 Definition and field of application**

(1) The Response Spectrum Analysis is an elastic calculation of the peak dynamic responses of all significant modes of the structure, using the ordinates of the site-dependent design spectrum (see EN 1998-1:2004, **3.2.2.5**). The overall response is

obtained by statistical combination of the maximum modal contributions. Such an analysis may be applied in all cases in which a linear analysis is allowed.

(2)P The earthquake action effects shall be determined from an appropriate discrete linear model (Full Dynamic Model), idealised in accordance with the laws of mechanics and the principles of structural analysis, and compatible with an associated idealisation of the seismic action. In general this model is a space model.

#### 4.2.1.2 Significant modes

(1)P All modes making significant contribution to the total structural response shall be taken into account.

(2) For bridges in which the total mass  $M$  can be considered as a sum of "effective modal masses"  $M_i$ , the criterion (1) is deemed to be satisfied if the sum of the effective modal masses for the modes considered,  $(\sum M_i)_c$ , amounts to at least 90% of the total mass of the bridge.

(3) If the condition (2) is not satisfied after consideration of all modes with  $T \geq 0,033$  sec, the number of modes considered may be deemed acceptable provided that both of the following conditions are satisfied:

- $(\sum M_i)_c / M \geq 0,70$
- The final values of the seismic action effects are multiplied by  $M / (\sum M_i)_c$

#### 4.2.1.3 Combination of modal responses

(1)P In general the probable maximum value  $E$  of a seismic action effect (force, displacement etc.), shall be taken as equal to the square root of the sum of squares of the modal responses,  $E_i$  (SRSS-rule)

$$E = \sqrt{\sum E_i^2} \quad (4.6)$$

This action effect shall be assumed to act with plus and minus signs.

(2)P When two modes have closely spaced natural periods the SRSS rule (expression (4.6)) is unconservative and more accurate rules shall be applied. Two natural periods,  $T_i, T_j$ , may be considered as closely spaced natural periods if they satisfy the condition:

$$\frac{0,1}{0,1 + \sqrt{\xi_i \xi_j}} \leq \rho_{ij} = T_i / T_j \leq 1 + 10 \sqrt{\xi_i \xi_j} \quad (4.7)$$

where  $\xi_i$  and  $\xi_j$  are the viscous damping ratios of modes  $i$  and  $j$  respectively (see (3)),.

(3) For any two modes satisfying expression (4.7), the method of the Complete Quadratic Combination (CQC) may be used instead of the SRSS rule:

$$E = \sqrt{\sum_i \sum_j E_i r_{ij} E_j} \quad (4.8)$$

with:  $i = 1 \dots n, j = 1 \dots n$

In expression (4.8)  $r_{ij}$  is the correlation factor:

$$r_{ij} = \frac{8\sqrt{\xi_i \xi_j} (\xi_i + \rho_{ij} \xi_j) \rho_{ij}^{3/2}}{(1 - \rho_{ij}^2)^2 + 4\xi_i \xi_j \rho_{ij} (1 + \rho_{ij}^2) + 4(\xi_i^2 + \xi_j^2) \rho_{ij}^2} \quad (4.9)$$

where:

$\xi_i, \xi_j$  are the viscous damping ratios  $i$  corresponding to modes  $i$  and  $j$  respectively.

NOTE Expression (4.9) gives  $r_{ij} = r_{ji}$ . When  $T_i = T_j$ , then  $\xi_i = \xi_j$  and  $r_{ij} = 1$ .

#### 4.2.1.4 Combination of the components of the seismic action

(1) The probable maximum action effect  $E$ , due to the simultaneous occurrence of the components of the seismic action along the horizontal axes  $X$  and  $Y$  and the vertical axis  $Z$ , may be estimated in accordance with EN 1998-1: 2004, **4.3.3.5.2(4)**, i.e. through application of the SRSS rule to the maximum action effects  $E_x, E_y$  and  $E_z$  due to independent seismic action along each axis:

$$E = \sqrt{E_x^2 + E_y^2 + E_z^2} \quad (4.10)$$

(2) Again in accordance with EN 1998-1: 2004, **4.3.3.5.2(4)**, the probable maximum action effect  $E$  may be taken as the most adverse of the effects calculated from EN 1998-1: 2004, expressions (4.18)-(4.22).

#### 4.2.2 Fundamental mode method

##### 4.2.2.1 Definition

(1) In the Fundamental mode method, equivalent static seismic forces are derived from the inertia forces corresponding to the fundamental mode and natural period of the structure in the direction under consideration, using the relevant ordinate of the site dependent design spectrum. The method also includes simplifications regarding the shape of the first mode and the estimation of the fundamental period.

(2) Depending on the particular characteristics of the bridge, this method may be applied using three different approaches for the model, namely:

- the Rigid Deck Model
- the Flexible Deck Model
- the Individual Pier Model

(3)P The rules of **4.2.1.4** for the combination of the components of seismic action shall be applied.



#### 4.2.2.2 Field of application

(1) The method may be applied in all cases in which the dynamic behaviour of the structure can be sufficiently approximated by a single dynamic degree of freedom model. This condition is considered to be satisfied in the following cases.

(a) In the longitudinal direction of approximately straight bridges with continuous deck, when the seismic forces are carried by piers the total mass of which is less than 20% of the mass of the deck.

(b) In the transverse direction of case (a), if the structural system is approximately symmetric about the centre of the deck, i.e. when the theoretical eccentricity  $e_0$  between the centre of stiffness of the supporting members and the centre of mass of the deck does not exceed 5% of the length of the deck ( $L$ ).

(c) In the case of piers carrying simply-supported spans, if no significant interaction between piers is expected and the total mass of each pier is less than 20% of the tributary mass of the deck.

#### 4.2.2.3 Rigid deck model

(1) This model may only be applied, when, under the seismic action, the deformation of the deck within a horizontal plane is negligible compared to the horizontal displacements of the pier tops. This condition is always met in the longitudinal direction of approximately straight bridges with continuous deck. In the transverse direction the deck may be assumed rigid either if  $L/B \leq 4,0$ , or if the following condition is satisfied:

$$\frac{\Delta_d}{d_a} \leq 0,20 \quad (4.11)$$

where:

$L$  is the total length of the continuous deck;

$B$  is the width of the deck; and

$\Delta_d$  and  $d_a$  are respectively the maximum difference and the average of the displacements in the transverse direction of all pier tops under the transverse seismic action, or under the action of a transverse load of similar distribution.

(2)P The earthquake effects shall be determined by applying a horizontal equivalent static force  $F$  at the deck given by the expression:

$$F = M S_d(T) \quad (4.12)$$

where:

$M$  is the total effective mass of the structure, equal to the mass of the deck plus the mass of the upper half of the piers;

$S_d(T)$  is the spectral acceleration of the design spectrum (EN 1998-1:2004, 3.2.2.5) corresponding to the fundamental period  $T$  of the bridge, estimated as:

$$T = 2\pi \sqrt{\frac{M}{K}} \quad (4.13)$$

where  $K = \sum K_i$  is the stiffness of the system, equal to the sum of the stiffnesses of the resisting members.

(3) In the transverse direction the force  $F$  may be distributed along the deck proportionally to the distribution of the effective masses.

#### 4.2.2.4 Flexible deck model

(1)P The Flexible Deck Model shall be used when expression (4.11) is not satisfied.

(2) Unless a more accurate calculation is made, the fundamental period of the structure in the horizontal direction considered, may be estimated via the Rayleigh quotient, using a generalised single-degree-of-freedom system, as follows:

$$T = 2\pi \sqrt{\frac{\sum M_i d_i^2}{g \sum M_i d_i}} \quad (4.14)$$

where:

$M_i$  is the mass at the  $i$ -th nodal point

$d_i$  is the displacement in the direction under examination when the structure is acted upon by forces  $gM_i$  acting at all nodal points in the horizontal direction considered.

(3)P The earthquake effects shall be determined by applying horizontal forces  $F_i$  at all nodal points given by:

$$F_i = \frac{4\pi^2}{gT^2} S_d(T) d_i M_i \quad (4.15)$$

where:

$T$  is the period of the fundamental mode of vibration for the horizontal direction considered,

$M_i$  is the mass concentrated at the  $i$ -th point,

$d_i$  is the displacement of the  $i$ -th nodal point in an approximation of the shape of the first mode (may be taken as equal to the values determined in (2) above),

$S_d(T)$  is the spectral acceleration of the design spectrum (EN 1998-1:2004, 3.2.2.5), and

$g$  is the acceleration of gravity.

#### 4.2.2.5 Torsional effects in the transverse direction (rotation about the vertical axis)

(1) When the Rigid or the Flexible Deck Model is used in the transverse direction of a bridge, torsional effects may be estimated by applying a static torsional moment  $M_t$  in accordance with expression (4.1) of 4.1.5(3)P. The relevant eccentricity shall be estimated as follows:

$$e = e_o + e_a \quad (4.16)$$

where:

$e_o$  is the theoretical eccentricity (see case (b) of 4.2.2.2(1))

$e_a = 0,05L$  is an additional eccentricity accounting for accidental and dynamic amplification effects

(2) The force  $F$  may be determined either from expression (4.12), or as  $\Sigma F_i$  from expression (4.15). The moment  $M_t$  may be distributed to the supporting members using the Rigid Deck Model.

#### 4.2.2.6 Individual pier model

(1) In some cases the seismic action in the transverse direction of the bridge is resisted mainly by the piers, without significant interaction between adjacent piers. In such cases the seismic action effects acting in the  $i$ -th pier may be approximated by applying on it an equivalent static force:

$$F_i = M_i S_d(T_i) \quad (4.17)$$

where

$M_i$  is the effective mass attributed to pier  $i$  and

$$T_i = 2\pi \sqrt{\frac{M_i}{K_i}} \quad (4.18)$$

is the fundamental period of the same pier, considered independently of the rest of the bridge.

(2) This simplification may be applied as a first approximation for preliminary analyses, when the following condition is met by the results of expression (4.18) for all adjacent piers  $i$  and  $i+1$ :

$$0,90 \leq T_i/T_{i+1} \leq 1,10 \quad (4.19)$$

Otherwise a redistribution of the effective masses attributed to each pier is required, leading to the satisfaction of the above condition.

### 4.2.3 Alternative linear methods

#### 4.2.3.1 Time series analysis

(1)P In a time series analysis, the design seismic action shall be taken as the average of the extreme response computed for each accelerogram in a set of time-histories considered. Subclause 3.2.3 applies for the choice of time-histories.

### 4.2.4 Non-linear dynamic time-history analysis

#### 4.2.4.1 General

(1)P The time dependent response of the structure shall be obtained through direct numerical integration of its non-linear differential equations of motion. The seismic input shall consist of ground motion time-histories (accelerograms, see 3.2.3). The effects of gravity loads and of the other quasi-permanent actions in the seismic design situation, as well as second order effects, shall be taken into account.

(2)P Unless otherwise specified in this Part, this method can be used only in combination with a standard response spectrum analysis to provide insight into the post-elastic response and comparison between required and available local ductility demands. Generally, the results of the non-linear analysis shall not be used to relax requirements resulting from the response spectrum analysis. However, in the cases of bridges with isolating devices (see Section 7) or irregular bridges (see 4.1.8) lower values estimated from a rigorous time-history analysis may be substituted for the results of the response spectrum analysis.

#### 4.2.4.2 Ground motions and design combination

(1)P The provisions of 3.2.3 apply.

(2)P The provisions of 5.5(1) and 4.1.2 apply.

#### 4.2.4.3 Design action effects

(1)P When non-linear dynamic analysis is performed for at least seven independent pairs of horizontal ground motions, the average of the individual responses may be used as the design value of the action effects, except if otherwise required in this part. When less than seven non-linear dynamic analyses are performed for the corresponding independent pairs of input motions, the maximum responses of the ensemble should be used as design action effects.

#### 4.2.4.4 Ductile structures

##### (1) Objectives

The main objectives of a non-linear time-history analysis of a ductile bridge are the following.

- The identification of the actual pattern of plastic hinge formation
- The estimation and verification of the probable post-yield deformation demands in plastic hinges and the estimation of the displacement demands
- The determination of the strength requirements for the prevention of non-ductile failure modes in the superstructure and for the verification of the soil.

## (2) Requirements

For a ductile structure subjected to high local ductility demands, achievement of the above objectives requires the following.

(a) A realistic identification of the extent of the structure that remains elastic. Such ~~Text deleted~~ identification should be based on probable values of the yield stresses and strains of the materials.

(b) In the regions of plastic hinges, the stress-strain diagrams for both concrete and reinforcement or structural steel, should reflect the probable post-yield behaviour, taking into account confinement of concrete, when relevant, and strain hardening and/or local buckling effects for steel. The shape of hysteresis loops should be properly modelled, taking into account strength and stiffness degradation and hysteretic pinching, if indicated by appropriate laboratory tests.

(c) The verification that deformation demands are safely lower than the capacities of the plastic hinges, should be performed by comparing plastic hinge rotation demands,  $\theta_{p,E}$ , to the relevant design rotation capacities,  $\theta_{p,d}$ , as follows:

$$\theta_{p,E} \leq \theta_{p,d} \quad (4.20)$$

The design values of the plastic rotation capacities,  $\theta_{p,d}$ , should be derived from relevant test results or calculated from ultimate curvatures, by dividing the probable value  $\theta_{p,u}$  by a factor,  $\gamma_{R,p}$ , that reflects local defects of the structure, uncertainties of the model and/or the dispersion of relevant test results, as follows:

$$\theta_{p,d} = \frac{\theta_{p,u}}{\gamma_{R,p}} \quad (4.21)$$

The same condition should be checked for other deformation demands and capacities of dissipative zones of steel structures (e.g. elongation of tensile members in diagonals and shear deformation of shear panels in eccentric bracings).

NOTE Informative Annex E gives information for the estimation of  $\theta_{p,d}$  and for  $\gamma_{R,p}$

(d) Member strength verification against bending with axial force is not needed, as such a verification is inherent in the non-linear analysis procedure according to (a) above. However it should be verified that no significant yield occurs in the deck (5.6.3.6(1)P and (2)).

(e) Verification of members against non-ductile failure modes (shear of members and shear in joints adjacent to plastic hinges), as well as of foundation failure, should be performed in accordance with the relevant rules of Section 5. The capacity design action

effects should be taken as the action effects resulting from the non-linear analysis multiplied by  $\gamma_{Bd1}$ , in accordance with **5.6.2(2)Pb**. These values should not exceed the design resistances  $R_d (= R_k/\gamma_M)$  of the corresponding sections, i.e.:

$$\max E_d \leq R_d \quad (4.22)$$

#### 4.2.4.5 Bridges with seismic isolation

(1) The objective of the analysis in this case is the realistic assessment of the displacement and force demands:

- properly taking into account the effect of the variability of the properties of the isolators, and
- ensuring that the isolated structure remains essentially elastic

(2) The provisions of Section 7 apply.

#### 4.2.5 Static non-linear analysis (pushover analysis)

(1)P Pushover analysis is a static non-linear analysis of the structure under constant vertical (gravity) loads and monotonically increased horizontal loads, representing the effect of a horizontal seismic component. Second order effects shall be accounted for. The horizontal loads are increased until a target displacement is reached at a reference point.

(2) The main objectives of the analysis are the following.

- The estimation of the sequence and the final pattern of plastic hinge formation;
- The estimation of the redistribution of forces following the formation of plastic hinges;
- The assessment of the force-displacement curve of the structure (“capacity curve”) and of the deformation demands of the plastic hinges up to the target displacement.

(3) The method may be applied to the entire bridge structure or to individual components.

(4) The requirements of **4.2.4.4(2)** apply, with the exception of the requirement for modelling of the hysteresis loop shape in **4.2.4.4(2)b**.

NOTE 1 A recommended procedure for the application of this method is given in Informative Annex H.

NOTE 2 It is noted that a static non-linear (pushover) analysis, such as the one given in Annex H, leads to realistic results in structures, the response of which to the horizontal seismic action in the direction considered can be reasonably approximated by a generalized one degree of freedom system. Assuming the influence of the pier masses to be minor, the above condition is always met in the longitudinal direction of approximately straight bridges. The condition is also met in the transverse direction, when the distribution of the stiffness of piers along the bridge provides a more or less uniform lateral support to a relatively stiff deck. This is the most common case for bridges where the height of the piers decreases towards the abutments or does not present intense variations. When, however, the bridge has one exceptionally stiff and unyielding pier, located between groups of regular piers, the system cannot be approximated in the transverse direction by a single-degree-of-freedom and the pushover analysis may not lead to realistic

results. A similar exception holds for long bridges, when very stiff piers are located between groups of regular ones, or in bridges in which the mass of some piers has a significant effect on the dynamic behaviour, in either of the two directions. Such irregular arrangements may be avoided, e.g. by providing sliding connection between the deck and the pier(s) causing the irregularity. If this is not possible or expedient, then non-linear time history analysis should be used.

## 5 STRENGTH VERIFICATION

### 5.1 General

(1)P The provisions of this Section apply to the earthquake resisting system of bridges designed by an equivalent linear method taking into account a ductile or limited ductile behaviour of the structure (see 4.1.6). For bridges provided with isolating devices, Section 7 shall be applied. For verifications on the basis of results of non-linear analysis, 4.2.4 applies. In both latter cases 5.2.1 applies.

### 5.2 Materials and design strength

#### 5.2.1 Materials

(1)P In bridges designed for ductile behaviour with  $q > 1,5$ , concrete members where plastic hinges may form, shall be reinforced with steel of Class C in accordance with EN 1992-1-1:2004, Table C.1.

(2) Concrete members of bridges designed for ductile behaviour, where no plastic hinges may form (as a consequence of capacity design), as well as all concrete members of bridges designed for limited ductile behaviour ( $q \leq 1,5$ ) or all concrete members of bridges with seismic isolation in accordance with Section 7, may be reinforced using steel of Class B in accordance with EN 1992-1-1:2004, Table C.4.

(3)P Structural steel members of all bridges shall conform to EN 1998-1: 2004, 6.2.

#### 5.2.2 Design strength

(1)P The design value of member resistance shall be determined in accordance with EN 1998-1:2004, 5.2.4, 6.1.3 or 7.1.3, as appropriate.

### 5.3 Capacity design

(1)P For structures designed for ductile behaviour, capacity design effects  $F_C$  ( $V_C$ ,  $M_C$ ,  $N_C$ ) shall be calculated by analysing the intended plastic mechanism under:

- a) the non-seismic actions in the design seismic situation and
- b) the level of seismic action in the direction under consideration (see (6)) at which all intended flexural hinges have developed bending moments equal to an upper fractile of their flexural resistance, called the overstrength moment,  $M_o$ .

(2) The capacity design effects need not be taken as greater than those resulting at the seismic design situation (see 5.5) in the direction under consideration, with the seismic action effects multiplied by the behaviour factor  $q$  used in the analysis for the design seismic action.

(3)P The overstrength moment of a section shall be calculated as:

$$M_o = \gamma_o M_{Rd} \quad (5.1)$$



where:

$\gamma_o$  is the overstrength factor;

$M_{Rd}$  is the design flexural strength of the section, in the selected direction and sign, based on the actual section geometry, including reinforcement where relevant, and material properties (with  $\gamma_M$  values for fundamental design situations). In determining  $M_{Rd}$ , biaxial bending shall be taken into account under: (a) the action effects of the non-seismic actions in the seismic design situation and (b) the other seismic action effects corresponding to the design seismic action with the selected direction and sign.

(4) The value of the overstrength factor should reflect the variability of material strength properties, and the ratio of the ultimate strength to the yield strength.

NOTE The value ascribed to  $\gamma_o$  for use in a country may be found in its National Annex. The recommended values are:

For concrete members:  $\gamma_o = 1,35$ ;

For steel members:  $\gamma_o = 1,25$ .

In the case of reinforced concrete sections with special confining reinforcement in accordance with **6.2.1**, and with the value of the normalized axial force

$$\eta_k = N_{Ed}/(A_c f_{ck}) \quad (5.2)$$

exceeding 0,1, the value of the overstrength factor shall be multiplied by  $1+2(\eta_k-0,1)^2$

where:

$N_{Ed}$  is the value of the axial force at the plastic hinge seismic design situation, positive if compressive;

$A_c$  is the cross-sectional area of the section; and

$f_{ck}$  is the characteristic concrete strength.

(5)P Within the length of members that develop plastic hinge(s), the capacity design bending moment  $M_c$  at the vicinity of the hinge (see Figure 5.1) shall not be assumed to be greater than the relevant design flexural resistance  $M_{Rd}$  of the nearest hinge calculated in accordance with **5.6.3.1**.

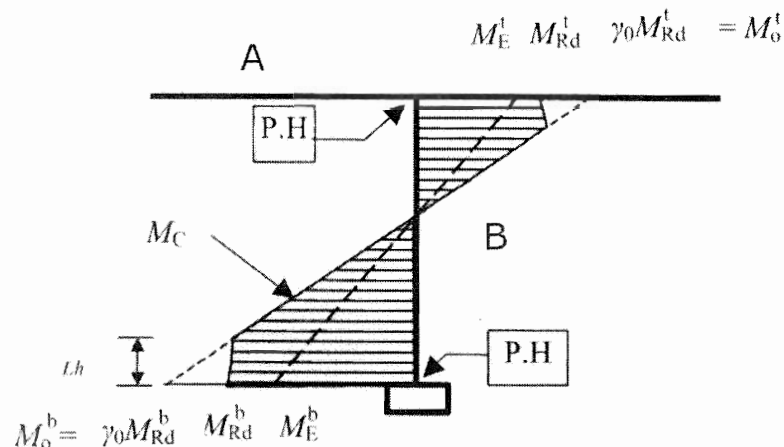

### Key

A – Deck  
 B – Pier  
 PH – Plastic Hinge

**Figure 5.1: Capacity design moments  $M_C$  within the length of member containing plastic hinges**

NOTE 1: The  $M_{Rd}$ -diagrams shown in Figure 5.1 correspond to a pier with variable cross-section (increasing downwards). In the case of a constant cross-section with constant reinforcement,  $M_{Rd}$  is also constant.

NOTE 2: For  $L_h$  see 6.2.1.5.

(6) In general capacity design effects should be calculated separately for seismic action acting (with + and – sign) in each of the longitudinal and the transverse directions. A relevant procedure and simplifications are given in Annex G.

(7)P When sliding bearings participate in the plastic mechanism, their capacity shall be assumed as equal to  $\gamma_{of} R_{df}$ , where:

$\gamma_{of} = 1,30$  is a magnification factor for friction due to ageing effects and

$R_{df}$  is the maximum design friction force of the bearing.

(8)P In bridges with elastomeric bearings and intended to have ductile behaviour, members where no plastic hinges are intended to form and which resist shear forces from the bearings shall be designed as follows: the capacity design effects shall be calculated on the basis of the maximum deformation of the bearings corresponding to the design displacement of the deck and a bearing stiffness increased by 30%.

## 5.4 Second order effects

(1) For linear analysis, approximate methods may be used for estimating the influence of second order effects on the critical sections (plastic hinges), also taking into account the cyclic character of the seismic action wherever it has a significant unfavourable effect.

NOTE: Approximate methods for use in a country to estimate second order effects under seismic actions may be found in its National Annex. The recommended procedure is to assume that the increase of bending moments of the plastic hinge section due to second order effects, is:

$$\Delta M = \frac{1+q}{2} d_{Ed} N_{Ed} \quad (5.3)$$

where  $N_{Ed}$  is the axial force and  $d_{Ed}$  is the relative transverse displacement of the ends of the considered ductile member, both in the design seismic situation.

## 5.5 Combination of the seismic action with other actions

(1)P The design value  $E_d$  of the effects of actions in the seismic design situation shall be determined in accordance with EN 1990:2002, **6.4.3.4** and EN 1998-1:2004, **3.2.4(1)** as:

$$E_d = G_k "+" P_k "+" A_{Ed} "+" \psi_{21} Q_{1k} "+" Q_2 \quad (5.4)$$

where:

“+” implies “to be combined with”;

$G_k$  are the permanent actions with their characteristic values;

$P_k$  is the characteristic value of prestressing after all losses;

$A_{Ed}$  is the design seismic action;

$Q_{1k}$  is the characteristic value of the traffic load;

$\psi_{21}$  is the combination factor for traffic loads in accordance with **4.1.2(3)P**; and

$Q_2$  is the quasi-permanent value of actions of long duration (e.g. earth pressure, buoyancy, currents etc.)

NOTE Actions of long duration are considered to be concurrent with the design seismic action.

(2)P Seismic action effects need not be combined with action effects due to imposed deformations (caused by temperature, shrinkage, settlements of supports, residual ground movements due to seismic faulting).

(3)P An exception to the rule in (2)P is the case of bridges in which the seismic action is resisted by elastomeric laminated bearings (see also **6.6.2.3(4)**). In such a case elastic behaviour of the system shall be assumed and the action effects due to imposed deformations shall be accounted for.

NOTE In the case of (3)P the displacement due to creep does not normally induce additional stresses to the system and can therefore be neglected. Creep also reduces the effective stresses induced in the structure by long-term imposed deformations (e.g. by shrinkage).

(4)P Wind and snow actions shall be neglected in the design value  $E_d$  of the effects of actions in the seismic design situation (expression (5.4)).

## 5.6 Resistance verification of concrete sections

### 5.6.1 Design resistance

(1) When the resistance of a section depends on multi-component action effects (e.g. bending moment, uniaxial or biaxial and axial force), the Ultimate Limit State conditions specified in **5.6.2** and **5.6.3** may be satisfied by considering separately the extreme (maximum or minimum) value of each component of the action effect with the concurrent values of all other components of the action effect.

### 5.6.2 Structures of limited ductile behaviour

(1)P For flexural resistance of sections the following condition shall be satisfied:

$$E_d \leq R_d \quad (5.5)$$

where:

$E_d$  is the design action effect in the seismic design situation including second order effects; and

$R_d$  is the design flexural resistance of the section in accordance with EN 1992-1-1:2004, **6.1** and with **5.6.1(1)**.

(2)P Verifications of shear resistance of concrete members shall be carried out in accordance with EN 1992-1-1:2004, **6.2**, with the following additional rules.

- a) The design action effects shall be calculated in accordance with **5.5(1)P**, where the seismic action effect  $A_{Ed}$  shall be multiplied by the behaviour factor  $q$  used in the linear analysis.
- b) The resistance values,  $V_{Rd,c}$ ,  $V_{Rd,s}$  and  $V_{Rd,max}$  derived in accordance with EN 1992-1-1:2004, **6.2** shall be divided by an additional safety factor  $\gamma_{Bdl}$  against brittle failure.

NOTE The value ascribed to  $\gamma_{Bdl}$   $\overline{AC1}$  for  $\overline{AC1}$  use in a country may be found in its National Annex. The recommended value is  $\gamma_{Bdl} = 1,25$ .

### 5.6.3 Structures of ductile behaviour

#### 5.6.3.1 Flexural resistance of sections of plastic hinges

(1)P The following condition shall be satisfied.

$$M_{Ed} \leq M_{Rd} \quad (5.6)$$

where:

$M_{Ed}$  is the design value of the moment as derived from the analysis for the seismic design situation, including second order effects; and

$M_{Rd}$  is the design flexural resistance of the section, in accordance with **5.6.1(1)**.

(2)P The longitudinal reinforcement of the member containing the hinge shall remain constant and fully effective over the length  $L_h$  shown in Figure 5.1 and specified in **6.2.1.5**.

### 5.6.3.2 Flexural resistance of sections outside the region of plastic hinges

(1)P The following condition shall be satisfied.

$$M_C \leq M_{Rd} \quad (5.7)$$

where :

$M_C$  is the capacity design moment as specified in **5.3**; and

$M_{Rd}$  is the design resistance of the section in accordance with EN 1992-1-1:2004, **6.1** taking into account the interaction of the other components of the design action effect (axial force and, when applicable, bending moment in the orthogonal direction).

NOTE As a consequence of **5.3(5)P**, the cross-section and the longitudinal reinforcement of the plastic hinge section shall not be affected by the capacity design verification.

### 5.6.3.3 Shear resistance of members outside the region of plastic hinges

(1)P Verifications of shear resistance shall be carried out in accordance with EN 1992-1-1:2004, **6.2**, with the following additional rules:

- a) The design action effects shall be assumed equal to the capacity design effects in accordance with **5.3**;
- b) The resistance values,  $V_{Rd,c}$ ,  $V_{Rd,s}$  and  $V_{Rd,max}$  derived in accordance with EN 1992-1-1:2004, **6.2** shall be divided by an additional safety factor  $\gamma_{Bd}$  against brittle failure. One of the following two alternatives shall be used for the value of  $\gamma_{Bd}$ .

$$\text{Alternative 1: } 1 \leq \gamma_{Bd} = \gamma_{BdI} + 1 - \frac{qV_{Ed}}{V_{C,o}} \leq \gamma_{BdI} \quad (5.8a)$$

$$\text{Alternative 2: } 1 \leq \gamma_{Bd} = \gamma_{BdI} \quad (5.8b)$$

where:

$\gamma_{BdI}$  is in accordance with **5.6.2(2)P**;

$V_{Ed}$  is the maximum value of the shear in seismic design situation of **5.5(1)P**; and

$V_{C,o}$  is the capacity design shear determined in accordance with **5.3**, without considering the limitation of **5.3(2)**.

NOTE: As shown in Fig. 5.2N, Alternative 2 is more conservative. The choice between Alternative 1 and Alternative 2 for use in a country may be found in its National Annex.

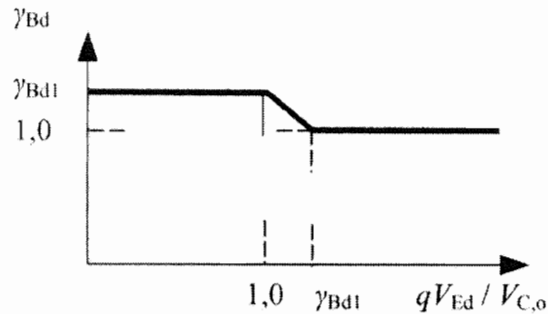

Figure 5.2N : Alternative expressions (5.8a), (5.8b)

(2) Unless a more accurate calculation is made, for circular concrete sections of radius  $r$  where the longitudinal reinforcement is distributed over a circle with radius  $r_s$ , the effective depth:

$$d_c = r + \frac{2r_s}{\pi} \quad (5.9)$$

may be used instead of  $d$  in the relevant expressions for the shear resistance. The value of the internal lever arm  $z$  may be assumed to be equal to:  $z = 0,9d_c$ .

#### 5.6.3.4 Shear resistance of plastic hinges

(1)P Subclause 5.6.3.3(1)P applies.

(2)P The angle  $\theta$  between the concrete compression strut and the main tension chord shall be assumed to be equal to  $45^\circ$ .

(3)P The dimensions of the confined concrete core to the centre line of the perimeter hoop shall be used in lieu of the section dimensions  $b_w$  and  $d$ .

(4) Subclause 5.6.3.3(2) may be applied using the dimensions of the confined concrete core.

(5) For members with shear span ratio  $\alpha_s < 2,0$  (see Table 4.1 for the definition of  $\alpha_s$ ), verification of the pier against diagonal tension and sliding failure should be carried out in accordance with EN 1998-1:2004, 5.5.3.4.3 and 5.5.3.4.4, respectively. In these verifications, the capacity design effects should be used as design action effects.

### 5.6.3.5 Verification of joints adjacent to plastic hinges

#### 5.6.3.5.1 General

(1)P Any joint between a vertical ductile pier and the deck or a foundation element adjacent to a plastic hinge in the pier, shall be designed in shear to resist the capacity design effects of the plastic hinge in the relevant direction. The pier is indexed in the following paragraphs with “c” (for “column”), while any other member framing into the same joint is referred to as “beam” and indexed with “b”.

(2)P For a vertical solid pier of depth  $h_c$  and of width  $b_c$  transverse to the direction of flexure of the plastic hinge, the effective width of the joint shall be assumed as follows:

- when the pier frames into a slab or a transverse rib of a hollow slab:

$$b_j = b_c + 0,5h_c \quad (5.10)$$

- when the pier frames directly into a longitudinal web of width  $b_w$  ( $b_w$  is parallel to  $b_c$ ):

$$b_j = \min(b_w; b_c + 0,5h_c) \quad (5.11)$$

- for circular piers of diameter  $d_c$ , the above definitions are applied assuming  $b_c = h_c = 0,9d_c$

#### 5.6.3.5.2 Joint forces and stresses

(1)P The design vertical shear of the joint,  $V_{jz}$ , shall be assumed as:

$$V_{jz} = \gamma_0 T_{Rc} - V_{b1c} \quad (5.12)$$

where:

$T_{Rc}$  is the resultant force of the tensile reinforcement of the pier corresponding to the design flexural resistance,  $M_{Rd}$ , of the plastic hinge in accordance with 5.3(3)P, and  $\gamma_0$  is the overstrength factor in accordance with 5.3(3)P and 5.3(4) (capacity design); and

$V_{b1c}$  is the shear force of the “beam” adjacent to the tensile face of the column, corresponding to the capacity design effects of the plastic hinge.

(2) The design horizontal shear of the joint  $V_{jx}$  may be calculated as (see Figure 5.3):

$$V_{jx} = V_{jz} \frac{z_c}{z_b} \quad (5.13)$$

where  $z_c$  and  $z_b$  are the internal lever arms of the plastic hinge and the “beam” end sections, respectively, and  $z_c$  and  $z_b$  may be assumed to be equal to 0,9 times the relevant effective section depths (see 5.6.3.3 and 5.6.3.4).

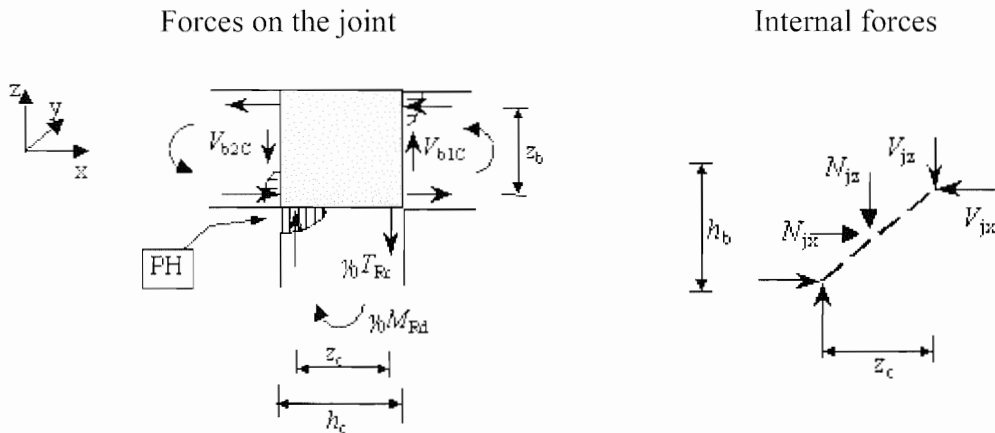

**Key**  
 PH – Plastic Hinge

**Figure 5.3: Joint forces**

(3) The shear verification should be carried out at the centre of the joint, where, in addition to  $V_{jz}$  and  $V_{jx}$ , the influence of following axial forces may be taken into account:

– vertical axial joint force  $N_{jz}$  equal to:

$$N_{jz} = \frac{b_c}{2b_j} N_{cG} \quad (5.14)$$

where:

$N_{cG}$  is the axial force of the column under the non-seismic actions in the design seismic situation;

horizontal force  $N_{jx}$  equal to the capacity design axial force effects in the “beam”, including the effects of longitudinal prestressing after all losses, if such axial forces are actually effective throughout the width  $b_j$  of the joint;

horizontal force  $N_{jy}$  in the transverse direction equal to the effect of transverse prestressing after all losses, effective within the depth  $h_c$ , if such prestressing is provided.

(4) For the joint verification the following average nominal stresses are used.

Shear stresses:

$$v_j = v_x = v_z = \frac{V_{jx}}{b_j z_c} = \frac{V_{jz}}{b_j z_b} \quad (5.15)$$

Axial stresses:

$$n_z = \frac{N_{jz}}{b_j h_c} \quad (5.16)$$



$$n_x = \frac{N_{jx}}{b_j h_b} \quad (5.17)$$

$$n_y = \frac{N_{jy}}{h_b h_c} \quad (5.18)$$

NOTE: As pointed out in 5.3(6), the capacity design, and therefore the relevant joint verification, should be carried out with both signs of the seismic action, + and -. It is also noted that at knee-joints (e.g. over the end column of a multi-column bent in the transverse bridge direction), the sign of  $M_{Rd}$  and  $V_{b1c}$  may be opposite to that shown in Figure 5.3 and  $N_{jx}$  may be tensile.

### 5.6.3.5.3 Verifications

(1) If the average shear stress in the joint,  $v_j$ , does not exceed the cracking shear capacity of the joint,  $v_{j,cr}$ , as given by expression (5.19), then minimum reinforcement should be provided, in accordance with (6)P.

$$v_j \leq v_{j,cr} = f_{ctd} \sqrt{\left(1 + \frac{n_x}{f_{ctd}}\right) \left(1 + \frac{n_z}{f_{ctd}}\right)} \leq 1,50 f_{ctd} \quad (5.19)$$

where:  $f_{ctd} = f_{ctk0,05}/\gamma_c$  is the design value of the tensile strength of concrete.

(2)P The diagonal compression induced in the joint by the diagonal strut mechanism shall not exceed the compressive strength of concrete in the presence of transverse tensile strains, taking into account also confining pressures and reinforcement.

(3) Unless a more accurate model, the requirement of (2)P above is deemed to be satisfied, if the following condition is met.

$$v_j \leq v_{j,Rd} = 0,5 \alpha_c v f_{cd} \quad (5.20)$$

where,

$$v = 0,6 (1 - (f_{ck}/250)) \quad (\text{with } f_{ck} \text{ in MPa}) \quad (5.21)$$

The factor  $\alpha_c$  in expression (5.20) accounts for the effects of any confining pressure ( $n_{jy}$ ) and/or reinforcement ( $\rho_y$ ) in the transverse direction  $y$ , on the compressive strength of the diagonal strut:

$$\alpha_c = 1 + 2(n_{jy} + \rho_y f_{sd})/f_{cd} \leq 1,5 \quad (5.22)$$

where:

$\rho_y = A_{sy}/(h_c h_b)$  is the reinforcement ratio of any closed stirrups in the transverse direction of the joint panel (orthogonal to the plane of action), and

$f_{sd} = 300$  MPa is a reduced stress of this transverse reinforcement, for reasons of limitation of cracking.

(4) Reinforcement, both horizontal and vertical, should be provided in the joint, at amounts adequate to carry the design shear force. This requirement may be satisfied by providing horizontal and vertical reinforcement ratios,  $\rho_x$  and  $\rho_z$ , respectively, such that:

$$\rho_x = \frac{v_j - n_x}{f_{sy}} \quad (5.23)$$

$$\rho_z = \frac{v_j - n_z}{f_{sy}} \quad (5.24)$$

where:

$\rho_x = \frac{A_{sx}}{b_j h_b}$  is the reinforcement ratio in the joint panel in the horizontal direction,

$\rho_z = \frac{A_{sz}}{b_j h_c}$  is the reinforcement ratio in the joint panel in the vertical direction, and

$f_{sy}$  is the design yield strength of the joint reinforcement.

(5)P The joint reinforcement ratios  $\rho_x$  and  $\rho_y$  shall not exceed the maximum value:

$$\rho_{\max} = \frac{v f_{cd}}{2 f_{sy}} \quad (5.25)$$

where  $v$  is given by expression (5.21)

(6)P A minimum amount of shear reinforcement shall be provided in the joint panel in both horizontal directions, in the form of closed links. The required minimum joint reinforcement ratio:

$$\rho_{\min} = \frac{f_{ctd}}{f_{sy}} \quad (5.26)$$

#### 5.6.3.5.4 Reinforcement arrangement

(1) Vertical stirrups should enclose the longitudinal “beam” reinforcement at the face opposite to the pier. Horizontal stirrups should enclose the pier vertical reinforcement, as well as “beam” horizontal bars anchored into the joint. Continuation of pier stirrups/hoops into the joint is recommended.

(2) Up to 50% of the total amount of vertical stirrups required in the joint may be U-bars, enclosing the longitudinal “beam” reinforcement at the face opposite to the column (see Figure 5.4).

(3) 50% of the bars of the top and bottom longitudinal reinforcement of the “beams”, when continuous through the joint body and adequately anchored beyond it, may be taken into account for covering the required horizontal joint reinforcement area  $A_{sx}$ .

(4) The longitudinal (vertical) pier reinforcement should reach as far as possible into the “beam”, ending just before the reinforcement layers of the “beam” at the face

opposite to the pier-“beam” interface. In the direction of flexure of the plastic hinge, the bars of both tensile regions of the pier should be anchored by a rectangular hook directed towards the centre of the pier.

(5) When the amount of required reinforcement  $A_{sz}$  and/or  $A_{sx}$ , in accordance with expressions (5.24) and (5.23) is so high as to impair constructability of the joint, then the alternative arrangement, described in (6) and (7), may be applied (see Figure 5.4).

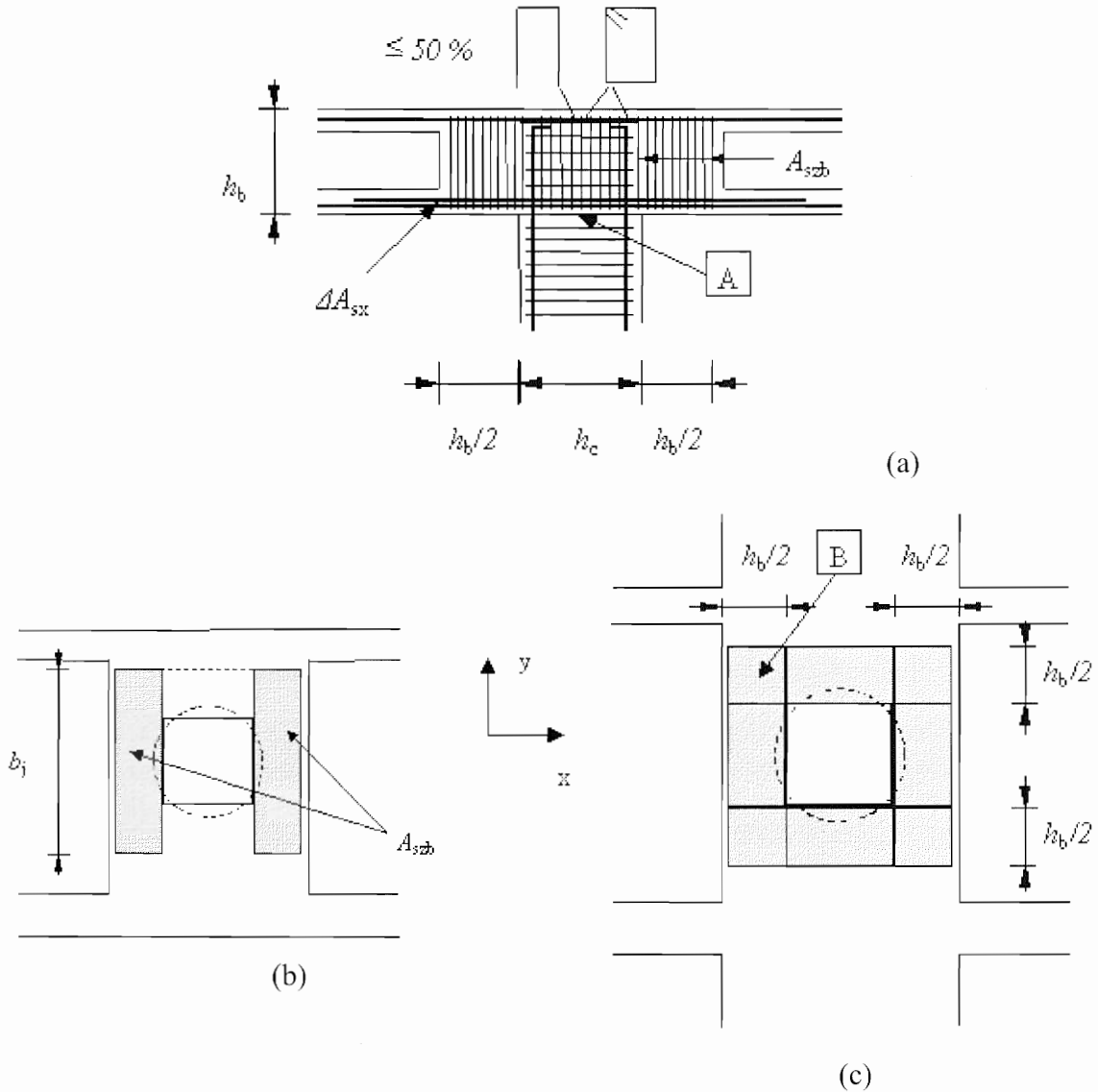

**Key**

A : “Beam”-pier interface

B : Stirrups in common areas count in both directions

**Figure 5.4: Alternative arrangement of joint reinforcement; (a) vertical section within plane xz; (b) plan view for plastic hinges forming in the x-direction; (c) plan view for plastic hinges in the x- and the y-directions.**

(6) Vertical stirrups of amount  $\rho_{1z} \geq \rho_{min}$ , acceptable from the constructability point of view, may be placed within the joint body. The remaining area  $\Delta A_{sz} = (\rho_z - \rho_{1z})b_j h_c$ , should be placed on each side of the “beam”, within the joint width  $b_j$  and not further than  $0,5h_b$  from the corresponding pier face.

(7) The horizontal reinforcement within the joint body may be reduced by  $\Delta A_{sx} \leq \Delta A_{sz}$ , provided that the ratio of the horizontal reinforcement remaining within the joint body satisfies expression (5.26). The tensile reinforcement of the “beam” top and bottom fibres at the faces of the pier should then be increased by  $\Delta A_{sx}$ , over the reinforcement required in the relevant “beam” sections for the verification in flexure under capacity design effects. Additional bars to cover this requirement should be placed within the joint width  $b_j$ ; these bars should be adequately anchored, so as to be fully effective at a distance  $h_b$  from the pier face.

### 5.6.3.6 Deck verification

(1)P It shall be verified that no significant yielding occurs in the deck. This verification shall be carried out:

- for bridges of limited ductile behaviour, under the most adverse design action effect in accordance with 5.5;
- for bridges of ductile behaviour, under the capacity design effects determined in accordance with 5.3.

(2) When the horizontal component of the seismic action in the transverse direction of the bridge is considered, yielding of the deck for flexure within a horizontal plane is considered to be significant if the reinforcement of the top slab of the deck yields up to a distance from its edge equal to 10% of the top slab width, or up to the junction of the top slab with a web, whichever is closer to the edge of the top slab.

(3) When verifying the deck on the basis of capacity design effects for the seismic action acting in the transverse direction of the bridge, the significant reduction of the torsional stiffness of the deck with increasing torsional moments should be accounted for. Unless a more accurate calculation is made, the values specified in 2.3.6.1(4) may be assumed for bridges of limited ductile behaviour, or 70% of these values for bridges of ductile behaviour.

## 5.7 Resistance verification for steel and composite members

### 5.7.1 Steel piers

#### 5.7.1.1 General

(1) For the verification of the pier under multi-component action effects, 5.6.1(1) applies.

(2)P Energy dissipation is allowed to take place only in the piers and not in the deck.

(3)P For bridges designed for ductile behaviour, the provisions of EN 1998-1:2004, 6.5.2, 6.5.4 and 6.5.5 for dissipative structures apply.

(4) The provisions of EN 1998-1:2004, 6.5.3 apply. However cross-sectional class 3 is allowed only when  $q \leq 1,5$ .

(5) The provisions of EN 1998-1:2004, **6.9** apply for all bridge piers.

#### **5.7.1.2 Piers as moment resisting frames**

(1)P In bridges designed for ductile behaviour, the design values of the axial force,  $N_{Ed}$ , and shear forces,  $V_{Ed}$ , in piers consisting of moment resisting frames shall be assumed to be equal to the capacity design action effects  $N_C$  and  $V_C$ , respectively, as the latter are specified in **5.3**.

(2)P The design of the sections of plastic hinges both in beams and columns of the pier shall satisfy the provisions of EN 1998-1:2004, **6.6.2**, **6.6.3** and **6.6.4**, using the values of  $N_{Ed}$  and  $V_{Ed}$  as specified in (1)P.

#### **5.7.1.3 Piers as frames with concentric bracings**

(1)P The provisions of EN 1998-1: 2004 apply with the following modifications for bridges designed for ductile behaviour.

- The design values for the axial shear force shall be in accordance with **5.3**, taking the force in all diagonals as corresponding to the overstrength  $\gamma_o N_{pl,Rd}$  of the weakest diagonal (see **5.3** for  $\gamma_o$ ).
- The second part of expression (6.12) in EN 1998-1:2004, **6.7.4** shall be replaced by the capacity design action  $N_{Ed} = N_C$

#### **5.7.1.4 Piers as frames with eccentric bracings**

(1)P The provisions of EN 1998-1:2004, **6.8** apply.

#### **5.7.2 Steel or composite deck**

(1)P In bridges designed for ductile behaviour ( $q > 1,5$ ) the deck shall be verified for the capacity design effects in accordance with **5.3**. In bridges designed for limited ductile behaviour ( $q \leq 1,5$ ) the verification of the deck shall be carried out using the design action effects from the analysis in accordance with expression (5.4). The verifications may be carried out in accordance with the relevant rules of EN 1993-2:2005 or EN 1994-2:2005 for steel or composite decks, respectively.

### **5.8 Foundations**

#### **5.8.1 General**

(1)P Bridge foundation systems shall be designed to conform to the general requirements set forth in EN 1998-5:2004, **5.1**. Bridge foundations shall not be intentionally used as sources of hysteretic energy dissipation and therefore shall, as far as practicable, be designed to remain elastic under the design seismic action.

(2)P Soil structure interaction shall be assessed where necessary on the basis of the relevant provisions of EN 1998-5: 2004, Section **6**.

### 5.8.2 Design action effects

(1)P For the purpose of resistance verifications, the design action effects on the foundations shall be determined in accordance with (2)P to (4).

(2)P Bridges of limited ductile behaviour ( $q \leq 1,5$ ) and bridges with seismic isolation

The design action effects shall be those resulting from expression (5.4) with seismic effects obtained from the linear analysis of the structure for the seismic design situation in accordance with 5.5, with the analysis results for the design seismic action multiplied by the  $q$ -factor used (i.e. effectively using  $q = 1$ ).

(3)P Bridges of ductile behaviour ( $q > 1,5$ ).

The design action effects shall be obtained by applying the capacity design procedure to the piers in accordance with 5.3.

(4) For bridges designed on the basis of non-linear analysis, the provisions of 4.2.4.4(2)e apply.

### 5.8.3 Resistance verification

(1)P The resistance verification of the foundations shall be carried out in accordance with EN 1998-5:2004, 5.4.1 (Direct foundations) and 5.4.2 (Piles and piers).

## 6 DETAILING

### 6.1 General

- (1)P The rules of this Section apply only to bridges designed for ductile behaviour and aim to ensure a minimum level of curvature/rotation ductility at the plastic hinges.
- (2)P For bridges of limited ductile behaviour, rules for the detailing of critical sections and specific non-ductile components are specified in **6.5**.
- (3)P In general, plastic hinge formation is not allowed in the deck. Therefore there is no need for the application of special detailing rules other than those applying for the design of bridges for the non-seismic actions.

### 6.2 Concrete piers

#### 6.2.1 Confinement

##### 6.2.1.1 General requirements

- (1)P Ductile behaviour of the compression concrete zone shall be ensured within the potential plastic hinge regions.
- (2)P In potential hinge regions where the normalised axial force (see **5.3(3)**) exceeds the limit:

$$\eta_k = N_{Ed}/A_c f_{ck} > 0,08 \quad (6.1)$$

confinement of the compression zone in accordance with **6.2.1.4** should be provided, except as specified in **(3)**.

- (3)P No confinement is required in piers if, under ultimate limit state conditions, a curvature ductility  $\mu_\phi = 13$  for bridges of ductile behaviour, or  $\mu_\phi = 7$  for bridges of limited ductile behaviour, is attainable, with the maximum compressive strain in the concrete not exceeding the value of:

$$\varepsilon_{cu2} = 0,35\% \quad (6.2)$$

NOTE: The condition of **(3)P** may be attainable in piers with flanged section, when sufficient flange area is available in the compressive zone.

- (4) In cases of deep compression zones, the confinement should extend at least up to the depth where the value of the compressive strain exceeds  $0,5\varepsilon_{cu2}$
- (5)P The quantity of confining reinforcement is defined through the mechanical reinforcement ratio:

$$\omega_{wd} = \rho_w \cdot f_{yd} / f_{cd} \quad (6.3)$$

where:

(a) In rectangular sections:

$\rho_w$  is the transverse reinforcement ratio defined as:

$$\rho_w = \frac{A_{sw}}{s_L b} \quad (6.4)$$

where:

$A_{sw}$  is the total area of hoops or ties in the one direction of confinement;

$s_L$  is the spacing of hoops or ties in the longitudinal direction;

$b$  is the dimension of the concrete core perpendicular to the direction of the confinement under consideration, measured to the outside of the perimeter hoop.

(b) In circular sections:

The volumetric ratio  $\rho_w$  of the spiral reinforcement relative to the concrete core is used:

$$\rho_w = \frac{4A_{sp}}{D_{sp} \cdot s_L} \quad (6.5)$$

where:

$A_{sp}$  is the area of the spiral or hoop bar

$D_{sp}$  is the diameter of the spiral or hoop bar

$s_L$  is the spacing of these bars.

### 6.2.1.2 Rectangular sections

(1)P The spacing of hoops or ties in the longitudinal direction,  $s_L$ , shall satisfy both of the following conditions:

- $s_L \leq 6$  times the longitudinal bar diameter,  $d_{bL}$
- $s_L \leq 1/5$  of the smallest dimension of the confined concrete core, to the hoop centre line.

(2)P The transverse distance  $s_T$  between hoop legs or supplementary cross-ties shall not exceed  $1/3$  of the smallest dimension  $b_{min}$  of the concrete core to the hoop centre line, nor 200mm (see Figure 6.1a).

(3)P Bars inclined at an angle  $\alpha > 0$  to the transverse direction in which  $\rho_w$  refers to shall be assumed to contribute to the total area  $A_{sw}$  of expression (6.4) by their area multiplied by  $\cos\alpha$ .



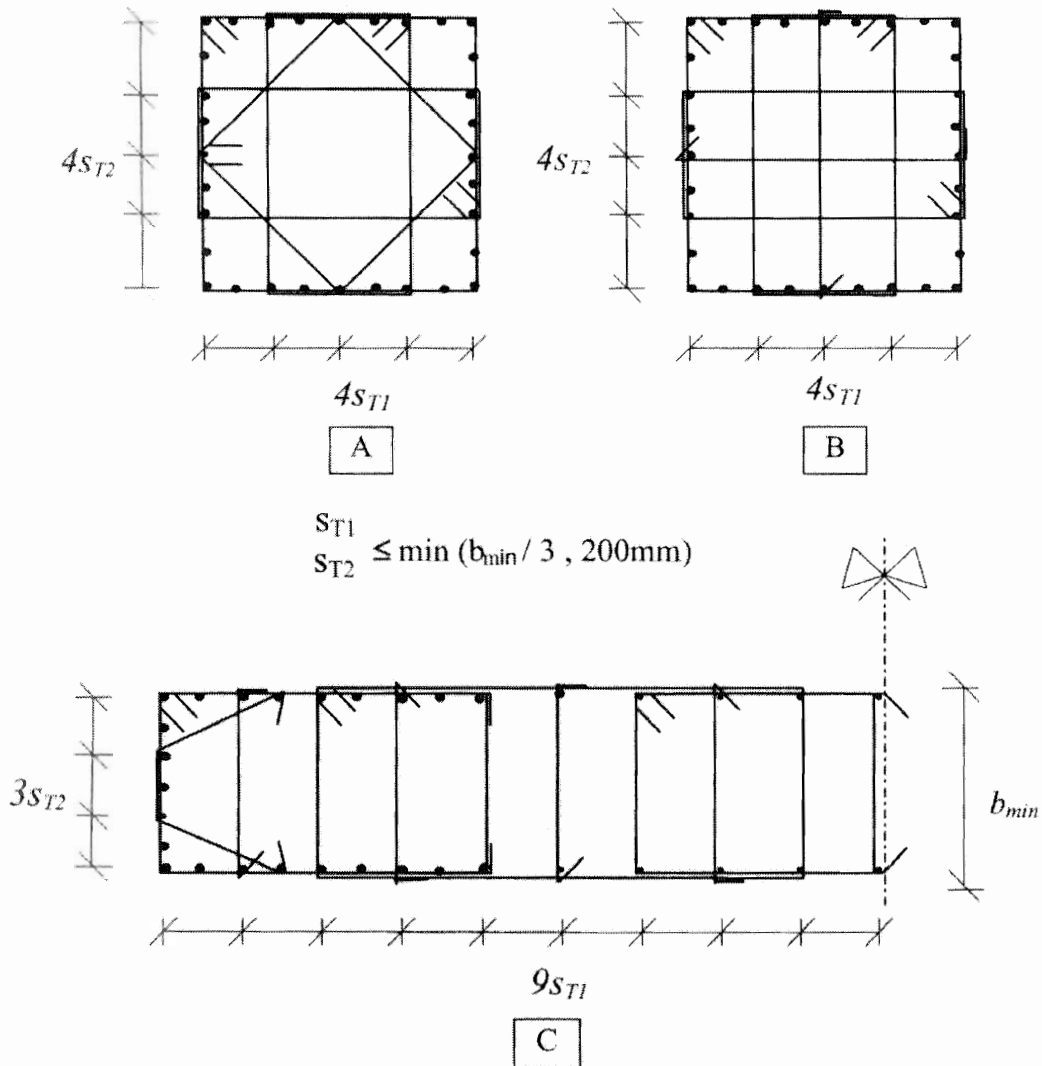

**Key**

- A : 4 closed overlapping hoops
- B : 3 closed overlapping hoops plus cross-ties
- C : closed overlapping hoops plus cross-ties

**Figure 6.1a: Typical confinement details in concrete piers with rectangular section using overlapping rectangular hoops and cross-ties**

**6.2.1.3 Circular sections**

(1)P The spacing of spiral or hoop bars,  $s_L$ , shall satisfy both of the following conditions:

$s_L \leq 6$  times the longitudinal bar diameter,  $d_{bL}$

$s_L \leq 1/5$  of the diameter of the confined concrete core to the hoop centre line.

#### 6.2.1.4 Required confining reinforcement

(1)P Confinement is implemented through rectangular hoops and/or cross-ties or through circular hoops or spirals.

NOTE The National Annex may prohibit the use of a certain type of confinement reinforcement. It is recommended that all types of confinement are allowed.

(2)P The minimum amount of confining reinforcement shall be determined as follows:

- for rectangular hoops and cross-ties

$$\omega_{wd,r} \geq \max\left(\omega_{w,req}; \frac{2}{3}\omega_{w,min}\right) \quad (6.6)$$

where:

$$\omega_{w,req} = \frac{A_c}{A_{cc}} \lambda \eta_k + 0,13 \frac{f_{yd}}{f_{cd}} (\rho_L - 0,01) \quad (6.7)$$

where:

$A_c$  is the area of the gross concrete section;

$A_{cc}$  is the confined (core) concrete area of the section to the hoop centerline;

$\omega_{w,min}$ ,  $\lambda$  are factors specified in Table 6.1; and

$\rho_L$  is the reinforcement ratio of the longitudinal reinforcement.

Depending on the intended seismic behaviour of the bridge, the minimum values specified in Table 6.1 apply.

**Table 6.1: Minimum values of  $\lambda$  and  $\omega_{w,min}$**

Seismic Behaviour	$\lambda$	$\omega_{w,min}$
Ductile	0,37	0,18
Limited ductile	0,28	0,12

- for circular hoops or spirals

$$\omega_{wd,c} \geq \max(1,4\omega_{w,req}; \omega_{w,min}) \quad (6.8)$$

(3)P When rectangular hoops and cross-ties are used, the minimum reinforcement condition shall be satisfied in both transverse directions.

(4)P Interlocking spirals/hoops are quite efficient for confining approximately rectangular sections. The distance between the centres of interlocking spirals/hoops shall not exceed  $0,6D_{sp}$ , where  $D_{sp}$  is the diameter of the spiral/hoop (see Figure 6.1b).

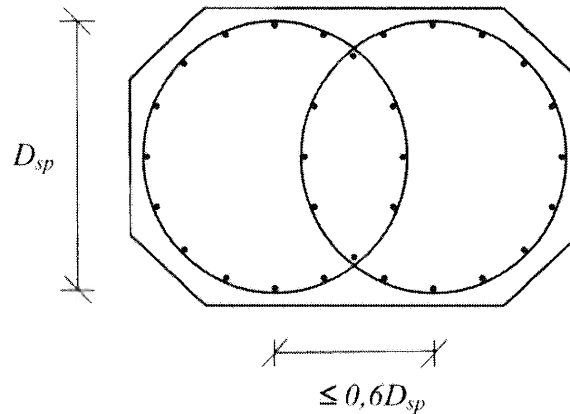

**Figure 6.1b: Typical confinement detail in concrete piers using interlocking spirals/hoops**

### 6.2.1.5 Extent of confinement - Length of potential plastic hinges

(1)P When  $\eta_k = N_{Ed}/A_c f_{ck} \leq 0,3$  the design length  $L_h$  of potential plastic hinges shall be estimated as the largest of the following values:

- the depth of the pier section within the plane of bending (perpendicular to the axis of rotation of the hinge);
- the distance from the point of maximum moment to the point where the design moment is less than 80% of the value of the maximum moment.

(2)P When  $0,6 \geq \eta_k > 0,3$  the design length of the potential plastic hinges as determined in (1)P shall be increased by 50%.

(3) The design length of plastic hinges ( $L_h$ ) defined above should be used exclusively for detailing the reinforcement of the plastic hinge. It should not be used for estimating the plastic hinge rotation.

(4)P When confining reinforcement is required, the amount specified in 6.2.1.4 shall be provided over the entire length of the plastic hinge. Outside the length of the hinge the transverse reinforcement may be gradually reduced to the amount required by other criteria. The amount of transverse reinforcement provided over an additional length  $L_h$  adjacent to the theoretical end of the plastic hinge shall not be less than 50% of the amount of the confining reinforcement required in the plastic hinge.

### 6.2.2 Buckling of longitudinal compression reinforcement

(1)P Buckling of longitudinal reinforcement shall be avoided along potential hinge areas, even after several cycles into the post-yield region.

(2) To meet the requirement in (1)P, all main longitudinal bars should be restrained against outward buckling by transverse reinforcement (hoops or cross-ties) perpendicular to the longitudinal bars at a (longitudinal) spacing  $s_L$  not exceeding  $\alpha l_{bL}$ ,

where  $d_{bL}$  is the diameter of the longitudinal bars. Coefficient  $\delta$  depends on the ratio  $f_t/f_y$  of the tensile strength  $f_{tk}$  to the yield strength  $f_{yk}$  of the transverse reinforcement, in terms of characteristic values, in accordance with the following relation:

$$5 \leq \delta = 2,5 (f_{tk}/f_{yk}) + 2,25 \leq 6 \quad (6.9)$$

(3) Along straight section boundaries, restraining of longitudinal bars should be  $\square{AC1}$  achieved  $\square{AC1}$  in either one of the following ways:

a) through a perimeter tie engaged by intermediate cross-ties at alternate locations of longitudinal bars, at transverse (horizontal) spacing  $s_t$  not exceeding 200 mm. The cross-ties shall have 135°-hooks at one end and 135°-hooks or 90°-hook at the other. Cross-ties with 135°-hooks at both ends may consist of two lapped spliced pieces. If  $\eta_k > 0,30$ , 90°-hooks are not allowed for the cross-ties. If the cross-ties have dissimilar hooks at the two ends, these hooks should be alternated in adjacent cross-ties, both horizontally and vertically. In sections of large dimensions the perimeter tie may be spliced using appropriate lapping length combined with hooks;

b) through overlapping closed ties arranged so that every corner bar and at least every alternate internal longitudinal bar is engaged by a tie leg. The transverse (horizontal) spacing  $s_T$  of the tie legs should not exceed 200 mm.

(4)P The minimum amount of transverse ties shall be determined as follows:

$$\square{AC1} \min \left( \frac{A_t}{s_L} \right) = \frac{\Sigma A_s f_{ys}}{1,6 f_{yt}} (mm^2/m) \quad (6.10)$$

where:

$A_t$  is the area of one tie leg, in  $mm^2$ ;

$s_L$  is the spacing of the legs along the axis of the member  $\square{AC1}$ , in m;

$\Sigma A_s$  is the sum of the areas of the longitudinal bars restrained by the tie, in  $mm^2$ ;

$f_{yt}$  is the yield strength of the tie; and

$f_{ys}$  is the yield strength of the longitudinal reinforcement.

### 6.2.3 Other rules

(1)P Due to the potential loss of concrete cover in the plastic hinge region, the confining reinforcement shall be anchored by 135°-hooks (unless a 90°-hook is used in accordance with 6.2.2(3)a) surrounding a longitudinal bar plus adequate extension (min. 10 diameters) into the core concrete.

(2)P Similar anchoring or a full strength weld is required for the lapping of spirals or hoops within potential plastic hinge regions. In this case laps of successive spirals or hoops, when located along the perimeter of the member, should be staggered in accordance with EN 1992-1-1:2004, 8.7.2.

(3)P No splicing by lapping or welding of longitudinal reinforcement is allowed within the plastic hinge region. For mechanical couplers see EN 1998-1:2004, 5.6.3(2).

## 6.2.4 Hollow piers

- (1) The rules of (2) to (4) are not required in cases of low seismicity.

NOTE: For cases of low seismicity the Notes in 2.3.7(1) apply.

(2) Unless appropriate justification is provided, the ratio  $b/h$  of the clear width  $b$  to the thickness  $h$  of the walls, in the plastic hinge region (length  $L_h$  in accordance with 6.2.1.5) of hollow piers with a single or multiple box cross-section, should not exceed 8.

(3) For hollow cylindrical piers the limitation (2) applies to the ratio  $D_i/h$ , where  $D_i$  is the inside diameter.

(4) In piers with simple or multiple box section and when the value of the ratio  $\eta_k$  defined in expression (6.1) does not exceed 0,20, there is no need for verification of the confining reinforcement in accordance with 6.2.1, provided that the requirements of 6.2.2 are met.

## 6.3 Steel piers

(1)P For bridges designed for ductile behaviour, the detailing rules of EN 1998-1:2004, 6.5, 6.6, 6.7 and 6.8, as modified by 5.7 of the present Part, shall be applied.

## 6.4 Foundations

### 6.4.1 Spread foundation

(1)P Spread foundations such as footings, rafts, box-type caissons, piers etc., shall not enter the plastic range under the design seismic action, and hence do not require special detailing reinforcement.

### 6.4.2 Pile foundations

(1)P When it is not feasible to avoid localised hinging in the piles, using the capacity design procedure (see 5.3), pile integrity and ductile behaviour shall be ensured. For this case following rules apply.

(2) The following locations along the pile should be detailed as potential plastic hinges.

(a) At the pile heads adjacent to the pile cap, when the rotation of the pile cap about a horizontal axis transverse to the seismic action is restrained by the large stiffness of the pile group in this degree-of-freedom.

(b) At the depth where the maximum bending moment develops in the pile. This depth should be estimated by an analysis that takes into account the effective pile flexural stiffness (see 2.3.6.1), the lateral soil stiffness and the rotational stiffness of the pile group at the pile cap.

(c) At the interfaces of soil layers with markedly different shear deformability, due to kinematic pile-soil interaction (see EN 1998-5:2004, 5.4.2(1)P).

(3) At locations of type (a) in (2), confining reinforcement of the amount specified in 6.2.1.4 along a vertical length equal to 3 times the pile diameter, should be provided.

(4) Unless a more accurate analysis is made, , , longitudinal as well as confining reinforcement of the same amount as that required at the pile head shall be provided over a length of two pile diameters on each side of the point of maximum moment at locations of type (b) in (2), and of each side of the interface at locations of type (c) in (2).

## 6.5 Structures of limited ductile behaviour

### 6.5.1 Verification of ductility of critical sections

(1)P The following rules apply at the critical sections of structures designed for limited ductile behaviour (with  $q \leq 1,5$ ) in cases other than those of low seismicity, to ensure a minimum of limited ductility.

NOTE 1: For the definition of cases of low seismicity see Note 1 in 2.3.7(1).

NOTE 2: The National Annex may define simplified verification rules for bridges designed for limited ductile behaviour in low seismicity cases. It is recommended to apply the same rules as in cases other than those of low seismicity.

(2)P A section is considered to be critical, i.e. location of a potential plastic hinge, when:

$$M_{Rd} / M_{Ed} < 1,30 \quad (6.11)$$

where:

$M_{Ed}$  is the maximum design moment at the section in the seismic design situation, and

$M_{Rd}$  is the minimum flexural resistance of the section in the seismic design situation.

(3) As far as possible, the location of potential plastic hinges should be accessible for inspection.

(4)P Unless confinement is not necessary according to 6.2.1.1(3)P, confining reinforcement as required by 6.2.1.4 for limited ductility (see Table 6.1), shall be provided in concrete members. In such cases it is also required to secure the longitudinal reinforcement against buckling in accordance with 6.2.2.

### 6.5.2 Avoidance of brittle failure of specific non-ductile components

(1)P Non-ductile structural components, such as fixed bearings, sockets and anchorages for cables and stays and other non-ductile connections shall be designed using either seismic action effects multiplied by the  $q$ -factor used in the analysis, or capacity design effects. The latter shall be determined from the strength of the relevant ductile members (e.g. the cables) and an overstrength factor of at least 1,3.

(2)P This verification may be omitted if it can be demonstrated that the integrity of the structure is not affected by failure of such connections. This demonstration shall also address the possibility of sequential failure, such as may occur in stays of cable-stayed bridges.

## **6.6 Bearings and seismic links**

### **6.6.1 General requirements**

(1)P Non-seismic horizontal actions on the deck shall be transmitted to the supporting members (abutments or piers) through the structural connections, which may be monolithic, or through bearings. For non-seismic actions the bearings shall be verified in accordance with the relevant standards (Parts 2 of relevant Eurocodes and EN 1337).

(2)P In general the design seismic action shall be transmitted through the bearings. However, seismic links (as specified in **6.6.3**) may be used to transmit the entire design seismic action, provided that dynamic shock effects are mitigated and taken into account in the design. Seismic links should generally allow the non-seismic displacements of the bridge to develop, without transmitting significant loads. When seismic links are used, the connection between the deck and the substructure should be properly modelled. As a minimum, a linear approximation of the force-displacement relationship of the linked structure shall be used (see Figure 6.2).

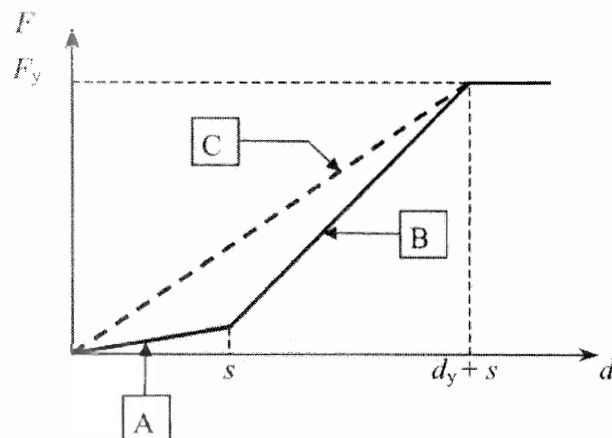

**Key**

- $s$  Slack of the link
- $d_y$  Yield deflection of supporting element
- A : Stiffness of bearing
- B : Stiffness of supporting element
- C : Linear approximation of the curve

**Figure 6.2: Force-displacement relationship for linked structure**

NOTE: Certain types of seismic links may not be applicable to bridges subject to large horizontal non-seismic actions, or to bridges with special displacement limitations, as for instance in railway bridges.

(3)P The structural integrity of the bridge shall be ensured under extreme seismic displacements. At fixed supports this requirement shall be implemented either through capacity design of the normal bearings (see 6.6.2.1), or through provision of additional links as a second line of defence (see 6.6.2.1(2) and 6.6.3.1(2)(b)). At moveable connections adequate overlap (seat) lengths in accordance with 6.6.4 shall be provided. In cases of retrofitting of existing bridge seismic links may be used as an alternative.

(4)P All types of bearings and seismic links shall be accessible for inspection and maintenance and shall be replaceable without major difficulty.

**6.6.2 Bearings**

**6.6.2.1 Fixed bearings**

(1)P Except under the conditions of (2), the design seismic action effects on fixed bearings shall be determined through capacity design.

(2) Fixed bearings may be designed solely for the effects of the seismic design situation from the analysis, provided that they can be replaced without difficulties and that seismic links are provided as a second line of defence.



### 6.6.2.2 Moveable bearings

(1)P Moveable bearings shall accommodate without damage the total design value of the displacement in the seismic design situation determined in accordance with **2.3.6.3(2)**.

### 6.6.2.3 Elastomeric bearings

(1) Elastomeric bearings may be used in the following arrangements:

a. on individual supports, to accommodate imposed deformations and resist only non-seismic horizontal actions, while the resistance to the design seismic action is provided by structural connections (monolithic or through fixed bearings) of the deck to other supporting members (piers or abutments);

b. on all or on individual supports, with the same function as in (a) above, combined with seismic links which are designed to resist the seismic action;

c. on all supports, to resist both the non-seismic and the seismic actions.

(2) Elastomeric bearings used in arrangements (a) and (b) of **(1)** shall be designed to resist the maximum shear deformation due to the design seismic action in accordance with **7.6.2(5)**.

(3) Under the conditions specified in **2.2.2(5)**, significant damage of elastomeric bearings of **(2)** is acceptable.

NOTE: The National Annex may define the extent of damage and the relevant verifications.

(4) The seismic behaviour of bridges, in which the design seismic action is resisted entirely by elastomeric bearings on all supports (arrangement **(1)c** above), is governed by the large flexibility of the bearings. Such bridges and the bearings shall be designed in accordance with Section 7.

## 6.6.3 Seismic links, holding-down devices, shock transmission units

### 6.6.3.1 Seismic links

(1) Seismic links may consist of shear key arrangements, buffers, and/or linkage bolts or cables. Friction connections are not considered as positive linkage.

(2) Seismic links are required in the following cases.

(a) In combination with elastomeric bearings, where the links are designed to carry the design seismic action.

(b) In combination with fixed bearings not designed for capacity design effects.

(c) In the longitudinal direction at moveable end-supports between the deck and the abutment or pier of existing bridges being retrofitted, if the requirements for minimum overlap length in **6.6.4** are not met.

(d) Between adjacent sections of the deck at intermediate separation joints (located within the span).

(3)P The design actions for the seismic links of the previous paragraph shall be determined as follows.

- In cases (a), (b) and (c) of (2) as capacity design effects (the horizontal resistance of the bearings shall be assumed to be equal to zero).
- In the case of (d) of (2), and unless a more accurate analysis is made taking into account the dynamic interaction of adjacent sections of the deck, the linkage elements may be designed for an action equal to  $1,5\alpha_g SM_d$  where  $\alpha_g$  is the design ground acceleration on type A ground, S is the soil factor from EN 1998-1: 2004, 3.2.2.2 and  $M_d$  is the mass of the section of the deck linked to a pier or abutment, or the least of the masses of the two deck sections on either side of the intermediate separation joint.

(4)P The links shall be provided with adequate slack or margins, so as to remain inactive:

- under the design seismic action in cases (c) and (d) of (2)
- under any non-seismic actions in case (a) of (2).

(5) When using seismic links, means for reducing shock effects should be provided.

#### 6.6.3.2 Holding-down devices

(1)P Holding down devices shall be provided at all supports where the total vertical reaction due to the design seismic action opposes and exceeds a percentage,  $p_H$ , of the compressive (downward) reaction due to the permanent load.

NOTE The value ascribed to  $p_H$  for use in a country may be found in its National Annex. The recommended value are as follows:

- $p_H = 80\%$  in bridges of ductile behaviour, where the vertical reaction due to the design seismic action is determined as a capacity design effect.
- $p_H = 50\%$  in bridges of limited ductile behaviour, where the vertical reaction due to the design seismic action is determined from the analysis under the design seismic action alone (including the contribution of the vertical seismic component).

(2) The requirement (1) refers to the total vertical reaction of the deck on a support and does not apply to individual bearings of the same support. However, no up-lift of individual bearings may take place in the seismic design situation in accordance with 5.5.

#### 6.6.3.3 Shock transmission units (STUs)

(1) Shock transmission units (STUs) are devices which provide velocity-dependent restraint of the relative displacement between the deck and the supporting element (pier or abutment), as follows.

- For low velocity movements ( $v < v_1$ ), such as those due to temperature effects or creep and shrinkage of the deck, the movement is practically free (with very low reaction).
- For high velocity movements ( $v > v_2$ ), such as those due to seismic or braking actions, the movement is blocked and the device acts practically as rigid connection.
- The units can also have a force limiting function, that limits the force transmitted through it (for  $v > v_2$ ) to a defined upper bound,  $F_{\max}$ , beyond which movement takes place.

NOTE The properties and the design of STUs will be covered by prEN 15129:200X (Antiseismic Devices). The order of magnitude of the velocities mentioned above is  $v_1 \cong 0,1$  mm/s,  $v_2 \cong 1,0$  mm/s.

(2)P Full description of the laws defining the behaviour of the units used (force-displacement and force-velocity relationships) shall be available at the design stage (from the manufacturer of the units), including any influence of environmental factors (mainly temperature, ageing, cumulative travel) on this behaviour. All values of parameters necessary for the definition of the behaviour of the units (including the values of  $v_1$ ,  $v_2$ ,  $F_{\max}$ , for the cases mentioned in (1)), as well as the geometric data and design resistance  $F_{Rd}$  of the units and their connections, shall also be available. Such information shall be based on appropriate official test results, or an ETA.

(3)P When STUs without force limiting function are used to resist seismic forces, they shall have a design resistance,  $F_{Rd}$ , as follows.

- For ductile bridges:  $F_{Rd}$  should be not less than the reaction corresponding to the capacity design effects,
- For limited ductile bridges:  $F_{Rd}$  should be not less than the reaction due to the design seismic action from the analysis, multiplied by the  $q$ -factor used.

The devices shall provide sufficient displacement capability for all slow velocity actions and shall retain their force capacity at their displaced state.

(4)P When STUs with force limiting function are used to resist seismic forces, the devices shall provide sufficient displacement capability to accommodate the total design value of the relative displacement,  $d_{Ed}$ , in the seismic design situation determined in accordance with 2.3.6.3(2)P, or in accordance with 7.6.2(2) for bridges with seismic isolation.

(5)P All STUs shall be accessible for inspection and maintenance/replacement.

#### 6.6.4 Minimum overlap lengths

(1)P At supports where relative displacement between supported and supporting members is intended under seismic conditions, a minimum overlap length shall be provided.

(2)P The overlap length shall be such as to ensure that the function of the support is maintained under extreme seismic displacements.

(3) At an end support of an abutment the minimum overlap length  $l_{ov}$  may be estimated as follows:

$$l_{ov} = l_m + d_{cg} + d_{cs} \quad (6.12)$$

$$d_{cg} = \varepsilon_c L_{eff} \leq 2d_g \quad (6.13)$$

$$\varepsilon_c = \frac{2d_g}{L_g} \quad (6.14)$$

where:

$l_m$  is the minimum support length ensuring the safe transmission of the vertical reaction, but no less than 400 mm,

$d_{cg}$  is the effective displacement of the two parts due to the spatial variation of the seismic ground displacement. When the bridge site is at a distance less than 5km of a known seismically active fault, capable of producing a seismic event of magnitude  $M \geq 6.5$ , and unless a specific seismological investigation is available, the value of  $d_{cg}$  to be used should be taken as double that obtained from expression (6.13).

$d_g$  is the design ground displacement in accordance with EN 1998-1:2004, **3.2.2.4**,

$L_g$  is the distance parameter specified in **3.3(6)**.

$L_{eff}$  is the effective length of the deck, taken as the distance from the deck joint in question to the nearest full connection of the deck to the substructure. If the deck is fully connected to a group of more than one piers, then  $L_{eff}$  shall be taken as the distance between the support and the centre of the group of piers. In this context “full connection” means a connection of the deck or deck section to a substructure member, either monolithically or through fixed bearings, seismic links, or STUs, without force limiting function.

$d_{cs}$  is the effective seismic displacement of the support due to the deformation of the structure, estimated as follows.

- For decks connected to piers either monolithically or through fixed bearings acting as full seismic links:

$$d_{cs} = d_{Ed}, \quad (6.15a)$$

where  $d_{Ed}$  is the total design value of the longitudinal displacement in the seismic design situation determined in accordance with expression (2.7) in **2.3.6.3**.

- For decks connected to piers or to an abutment through seismic links with slack equal to  $s$ :

$$d_{cs} = d_{Ed} + s \quad (6.15b)$$

(4) In the case of an intermediate separation joint between two sections of the deck,  $l_{ov}$  should be estimated by taking the square root of the sum of the squares of the values calculated for each of the two sections of the deck in accordance with (3). At an end support of a deck section on an intermediate pier,  $l_{ov}$  should be taken as the value

estimated in accordance with (3) plus the maximum displacement of the top of the pier in the seismic design situation,  $d_E$ .

## 6.7 Concrete abutments and retaining walls

### 6.7.1 General requirements

(1)P All critical structural components of the abutments shall be designed to remain essentially elastic under the design seismic action. The design of the foundation shall be in accordance with 5.8. Depending on the structural function of the horizontal connection between the abutment and the deck the provisions of 6.7.2 and 6.7.3 apply.

NOTE: Regarding controlled damage in abutment back-walls see 2.3.6.3(5).

### 6.7.2 Abutments flexibly connected to the deck

(1) In abutments flexibly connected to the deck, the deck is supported through sliding or elastomeric bearings. The elastomeric bearings (or the seismic links, if provided) may be designed to contribute to the seismic resistance of the deck, but not to that of the abutments.

(2) The following actions, assumed to act in phase, should be taken into account for the seismic design of these abutments.

a. Earth pressures including seismic effects determined in accordance with EN 1998-5:2004, Section 7.

b. Inertia forces acting on the mass of the abutment and on the mass of earthfill lying over its foundation. In general these effects may be determined on the basis of the design ground acceleration at the top of the ground of the site,  $a_g S$ .

c. Actions from the bearings determined as capacity design effects in accordance with 5.3(7)P and 5.3(8)P if a ductile behaviour has been assumed for the bridge. If the bridge is designed for  $q = 1,0$ , then the reactions on the bearings resulting from the seismic analysis shall be used.

(3) When the earth pressures assumed in (2)a are determined in accordance with EN 1998-5:2004, on the basis of an acceptable displacement of the abutment, provision for this displacement should be made in determining the gap between the deck and the abutment back-wall. In this case it should also be ensured that the displacement assumed in determining the actions in (2)a, can actually take place before a potential failure of the abutment itself occurs. This requirement is deemed to be satisfied if the design of the body of the abutment is effected using the seismic part of the actions in (2)a increased by 30%.

### 6.7.3 Abutments rigidly connected to the deck

(1) The connection of the abutment to the deck is considered as rigid, if it is either monolithic, or through fixed bearings, or through links designed to carry the seismic action. Such abutments have a major contribution to the seismic resistance, both in the longitudinal and in the transverse direction.

(2) The analysis model should incorporate the effect of interaction of the soil and the abutments, using either best-estimate values of the relevant soil stiffness parameters or values corresponding to upper and lower bound stiffness.

(3) When the seismic resistance of the bridge is provided by both piers and abutments, the use of upper and lower bound estimates of the soil stiffness is recommended, in order to arrive at results which are on the safe side both for the abutments and for the piers.

(4)P A behaviour factor  $q = 1,5$  shall be used, in the analysis of the bridge.

(5) The following actions should be taken into account in the longitudinal direction.

a. Inertia forces acting on the mass of the structure, which may be estimated using the Fundamental Mode Method (see **4.2.2**).

b. Static earth pressures acting on both abutments ( $E_o$ ).

c. The additional seismic earth pressures

$$\Delta E_d = E_d - E_o \quad (6.16)$$

where:

$E_d$  is the total earth pressure acting on the abutment under the design seismic action in accordance with EN 1998-5:2004. The pressures  $\Delta E_d$  are assumed to act in the same direction on both abutments.

(6) The connection of the deck to the abutment (including fixed bearings or links, if provided) should be designed for the action effects resulting from the above paragraphs. Reactions on the passive side may be taken into account in accordance with **(8)**.

(7) In order that damage of the soil or the embankment behind an abutment rigidly connected to the deck is kept within acceptable limits, the design seismic displacement should not exceed a limit value,  $d_{lim}$ , depending on the importance class of the bridge.

NOTE: The value ascribed to  $d_{lim}$  for use in a country may be found in its National Annex. The recommended values of  $d_{lim}$  are as follows:

**Table 6.2N. Recommended limit value of design seismic displacement at abutments rigidly connected to the deck**

Bridge Importance Class	Displacement Limit $d_{lim}$ (mm)
III	30
II	60
I	No limitation

(8) The soil reaction activated by the movement of the abutment, and of any wing-walls monolithically connected to it, towards the fill is assumed to act on the following surfaces.

- In the longitudinal direction, on the external face of the back-wall of that abutment which moves against the soil or fill.
- In the transverse direction, on the internal face of those wing-walls which move against the fill.

These reactions may be estimated on the basis of horizontal soil moduli corresponding to the specific geotechnical conditions.

The relevant abutment should be designed to resist this soil reaction, in addition to the static earth pressures.

(9) When an abutment is embedded in stiff natural soil formations over more than 80% of its height, it can be considered as fully locked-in. In that case  $q = 1$  should be used and the inertia forces should be determined on the basis of the design ground acceleration at the top of the ground of the site,  $a_g S$  (that is without spectral amplification).

#### 6.7.4 Culverts with large overburden

(1) In culverts with a large depth of fill over the top slab (exceeding 50% of its span), the assumptions of inertial seismic response used in 6.7.3 may not be applied, as they lead to unrealistic results. In such a case the inertial response should be neglected and the response should be calculated on the basis of kinematic compatibility between the culvert structure and free-field seismic deformation of the surrounding soil corresponding to the design seismic action.

(2) To this end the free-field seismic soil deformation may be assumed as a uniform shear-strain field (see Figure 6.3) with shear strain:

$$\gamma_s = \frac{v_g}{v_s} \quad (6.17)$$

where

$v_g$  is the peak ground velocity (see (3) below)

$v_s$  is the shear wave velocity in the soil under the shear strain corresponding to the ground acceleration. This value may be estimated from the value  $v_{s,max}$  for small strains, from EN 1998-5:2004, Table 4.1.

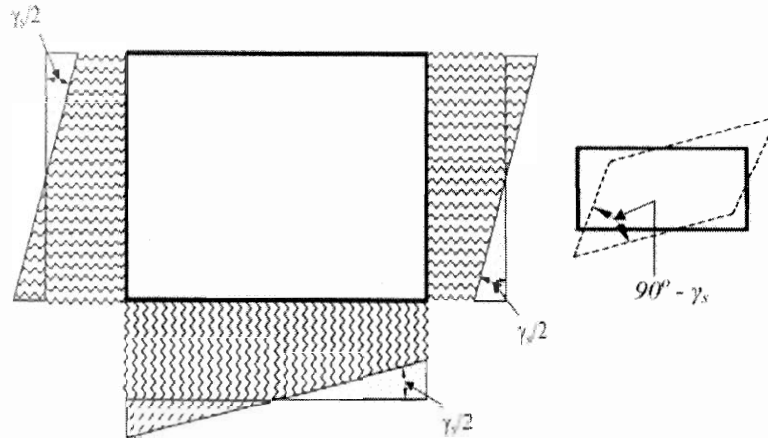

### Key

$\gamma_s$ : Free-field soil deformation

**Figure 6.3: Kinematic response of culvert**

(3) In the absence of specific data, the peak ground velocity should be estimated from the design ground acceleration  $a_g$  on type A ground, using the relation

$$v_g = \frac{ST_C a_g}{2\pi} \quad (6.18)$$

where  $S$  and  $T_C$  are in accordance with EN 1998-1:2004, 3.2.2.2.

### 6.7.5 Retaining walls

(1)P Free standing retaining walls shall be designed in accordance with 6.7.2(2) and (3), without any action from bearings.



## 7 BRIDGES WITH SEISMIC ISOLATION

### 7.1 General

(1)P This Section covers the design of bridges that are provided with a special isolating system, aiming to reduce their response due to horizontal seismic action. The isolating units are arranged over the isolation interface, usually located under the deck and over the top of the piers/abutments.

(2) The reduction of the response may be achieved:

- by lengthening of the fundamental period of the structure (effect of period shift in the response spectrum), which reduces forces but increases displacements;
- by increasing the damping, which reduces displacements and may reduce forces;
- (preferably) by a combination of the two effects.

### 7.2 Definitions

#### **isolating system**

collection of components used for providing seismic isolation, located at the isolation interface

#### **isolator units or isolators**

the individual components, constituting the isolation system. Each unit provides a single or a combination of the following functions:

- vertical-load carrying capability, combined with high lateral flexibility and high vertical rigidity;
- energy dissipation (hysteretic, viscous, frictional);
- lateral restoring capability;
- horizontal restraint (sufficient elastic stiffness) under non-seismic service horizontal loads

#### **substructure(s)**

part(s) of the structure located under the isolation interface, usually consisting of the piers and abutments. The horizontal flexibility of the substructures should in general be accounted for.

#### **superstructure**

part of the structure located above the isolation interface. In bridges this part is usually the deck

#### **effective stiffness centre**

stiffness centre  $C$  at the top of the isolation interface, considering the superstructure as rigid, but accounting for the flexibilities of the isolator units and of the substructure(s)

#### **design displacement ( $d_{cd}$ ) of the isolating system in a principal direction**

maximum horizontal displacement (relative to the ground) of the superstructure at the stiffness centre, occurring under the design seismic action

**design displacement ( $d_{bi}$ ) of an isolator  $i$**

displacement of the superstructure relative to the substructure at the location of the isolator, corresponding to the design displacement of the isolating system

**increased design displacement ( $d_{bi,a}$ ) of isolator  $i$**

design displacement of the isolator, multiplied by the amplification factor  $\gamma_S$  in accordance with 7.6.2

**maximum total displacement of isolator unit  $i$**

sum of the increased design displacement, the offset displacement due to permanent actions, long-term deformations of the superstructure (post-tensioning, shrinkage and creep for concrete decks) and 50% of the displacement due to thermal movements.

**effective stiffness of the isolating system in a principal direction**

ratio of the value of the total horizontal force transferred through the isolation interface, concurrent to the design displacement in the same direction, divided by the absolute value of the design displacement (secant stiffness).

**effective period**

fundamental period in the direction considered, of a single-degree-of-freedom system having the mass of the superstructure and stiffness equal to the effective stiffness of the isolating system, as specified in 7.5.4

**effective damping of the isolating system**

value of viscous damping ratio, corresponding to the energy dissipated by the isolation system during cyclic response at the design displacement

**simple low-damping elastomeric bearings**

laminated low-damping elastomeric bearings in accordance with EN 1337-3:2005, not subject to prEN 15129:200X (Antiseismic Devices) (see 7.5.2.3.3(5))

**special elastomeric bearings**

laminated high damping elastomeric bearings successfully tested in accordance with the requirements of prEN 15129:200X (Antiseismic Devices) (see 7.5.2.3.3(7)).

**7.3 Basic requirements and compliance criteria**

- (1)P The basic requirements set forth in 2.2 shall be satisfied.
- (2)P The seismic response of the superstructure and substructures under the design seismic design situations shall be assumed as limited ductile ( $q \leq 1,5$ ).
- (3) The bridge is deemed to satisfy the basic requirements, if it is designed in accordance with 7.4 and 7.5 and conforms to 7.6 and 7.7.
- (4)P Increased reliability is required for the strength and integrity of the isolating system, due to the critical role of its displacement capability for the safety of the bridge. This reliability is deemed to be achieved if the isolating system is designed in accordance with the requirements of 7.6.2.

(5)P For all types of isolator units, with the exception of simple elastomeric low-damping bearings in accordance with 7.5.2.3.3(5) and (6) and the flat sliding bearings in accordance with 7.5.2.3.5(5), the design properties shall be validated on the basis of Qualification and Prototype tests.

NOTE Informative annex K is intended to provide guidance on prototype testing in cases where prEN 15129:200X (“Anti-seismic devices”) does not include detailed requirements for type testing

## 7.4 Seismic action

### 7.4.1 Design spectra

(1)P The spectrum used shall be not lower than the elastic response spectrum specified in EN 1998-1:2004, 3.2.2.2 for non-isolated structures (see EN 1998-1:2004, 3.2.2.5(8)P).

NOTE Particular attention should be given to the fact that the safety of structures with seismic isolation depends mainly on the displacement demands for the isolating system that are directly proportional to the value of period  $T_D$ . Therefore, and in accordance with EN 1998-1:2004, 3.2.2.5(8)P, the National Annex to this Part of Eurocode 8 may specify a value of  $T_D$  specifically for the design of bridges with seismic isolation that is more conservative (longer) than the value ascribed to  $T_D$  in the National Annex to EN 1998-1:2004 (see also 3.2.2.3).

### 7.4.2 Time-history representation

(1)P The provisions of 3.2.3 apply.

## 7.5 Analysis procedures and modelling

### 7.5.1 General

(1) The following analysis procedures, with conditions for application specified in 7.5.3, are provided for bridges with seismic isolation.

- a) Fundamental mode spectrum analysis
- b) Multi-mode spectrum analysis
- c) Time-history non-linear analysis

(2)P In addition to the conditions specified in 7.5.3, the following are prerequisites for the application of methods (a) and (b) in (1)

- The usually non-linear force–displacement relationship of the isolating system shall be approximated with sufficient accuracy by the effective stiffness ( $K_{eff}$ ), i.e. the secant value of the stiffness at the design displacement (see Figure 7.1). This representation shall be based on successive approximations of the design displacement ( $d_{cd}$ ).
- The energy dissipation of the isolating system shall be expressed in terms of an equivalent viscous damping as the “effective damping” ( $\zeta_{eff}$ ).

(3) If the isolating system consists exclusively of simple low-damping elastomeric bearings (equivalent viscous damping ratio approximately 0,05), the normal linear dynamic analysis methods specified in 4.2 may be applied. The elastomeric bearings may be considered as linear elastic members, deforming in shear (and possibly in compression). Their damping may be assumed equal to the global viscous damping of the structure (see also 7.5.2.3.3(2)). The entire structure should remain essentially elastic.

## 7.5.2 Design properties of the isolating system

### 7.5.2.1 General

(1)P All isolators shall conform to EN pr15129:200X (Antiseismic Devices) or be covered by an ETA (European Technical Approval).

NOTE 1: prEN 15129:200X: Antiseismic Devices is being prepared by CEN/TC340. Until this EN is published by CEN, as well as for the case of isolators whose Prototype tests are not fully covered by this latter EN, the requirements given in Informative Annex K of the present standard may be used.

NOTE 2: Regarding simple low-damping elastomeric bearings in accordance with 7.5.2.3.3(4), (5) and (6) and lubricated PTFE (polytetrafluorethylene) flat sliding bearings used in accordance with 7.5.2.3.5(5) see references above as well as 7.5.2.4 (5), (6) and (7).

### 7.5.2.2 Stiffness in vertical direction

(1)P The isolator units that carry vertical loads shall be sufficiently stiff in the vertical direction.

(2) The requirement in (1)P is deemed to be satisfied if the horizontal displacement at the centre of mass of the superstructure, due to the vertical flexibility of the isolator units, is less than 5% of the design displacement  $d_{cd}$ . This condition need not be checked if sliding or simple low-damping elastomeric bearings are used as vertical load carrying elements at the isolation interface.

### 7.5.2.3 Design properties in horizontal directions

#### 7.5.2.3.1 General

(1) The design properties of the isolators depend on their behaviour, which may be one or a combination of those described in subclauses 7.5.2.3.2 to 7.5.2.3.5.

#### 7.5.2.3.2 Hysteretic behaviour

(1) The force-displacement relationship of the isolator unit in the horizontal direction may be approximated by a bi-linear relationship, as shown in Figure 7.1, for an isolator unit  $i$  (index  $i$  is omitted).

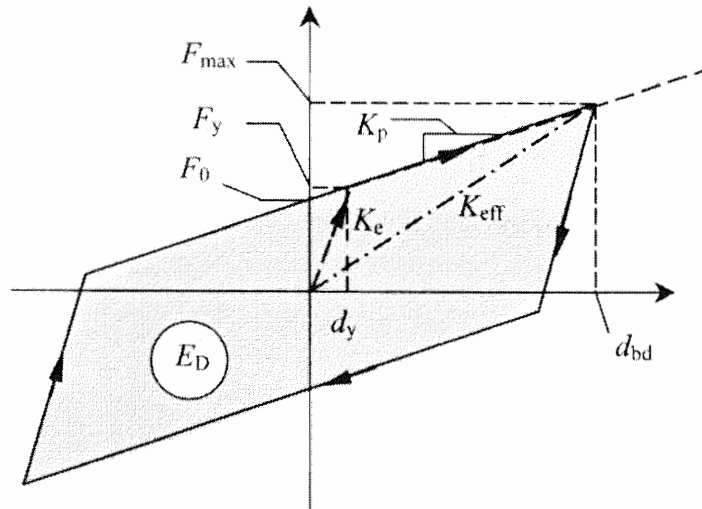

**Figure 7.1: Bilinear approximation of hysteretic force-displacement behaviour**

(2) The parameters of the bi-linear approximation are the following:

$d_y$  = yield displacement;

$d_{bd}$  = design displacement of the isolator corresponding to the design displacement  $d_{cd}$  of the isolating system;

$E_D$  = dissipated energy per cycle at the design displacement  $d_{bd}$ , equal to the area enclosed by the actual hysteresis loop =  $4(F_y d_{bd} - F_{max} d_y)$ ;

$F_y$  = yield force under monotonic loading;

$F_0$  = force at zero displacement under cyclic loading =  $F_y - K_p d_y$ ;

$F_{max}$  = maximum force, corresponding to the design displacement  $d_{bd}$ ;

$K_e$  = elastic stiffness at monotonic loading =  $F_y/d_y$ , equal also to the unloading stiffness in cyclic loading;

$K_p$  = post-elastic (tangent) stiffness =  $(F_{max} - F_y)/(d_{bd} - d_y)$ .

### 7.5.2.3.3 Behaviour of elastomeric bearings

(1) Elastomeric bearings considered in this Part are laminated rubber bearings consisting of rubber layers reinforced by integrally bonded steel plates. With regard to damping, elastomeric bearings are distinguished in low-damping and high-damping bearings.

(2) Low-damping elastomeric bearings are those with an equivalent viscous damping ratio  $\xi$  less than 0,06. Such bearings have a cyclic behaviour similar to hysteretic behaviour with very slender hysteresis loops. Their behaviour should be approximated by that of a linear elastic member with equivalent elastic stiffness in the horizontal direction equal to  $G_b A_b / t_c$  where  $G_b$  is the shear modulus of the elastomer (see 7.5.2.4(5)),  $A_b$  its effective horizontal area and  $t_c$  is the total thickness of the elastomer.

(3) High-damping elastomeric bearings exhibit substantial hysteresis loops, corresponding to an equivalent viscous damping ratio  $\zeta$  usually between 0,10 and 0,20. Their behaviour should be considered as linear hysteretic.

(4) From the point of view of required special tests for seismic performance, elastomeric bearings are distinguished in this part as simple low-damping and special elastomeric bearings.

(5) Low-damping bearings conforming to EN 1337-3:2005 are defined as simple low-damping elastomeric bearings.

(6) Simple low-damping elastomeric bearings may be used as isolators, without being subjected to special tests for seismic performance.

(7) Special elastomeric bearings are high damping elastomeric bearings specially tested in accordance with the requirements of EN pr15129:200X (Antiseismic Devices).

(8) The design properties of elastomeric bearings used in this Section should cover both the unscragged and the scragged conditions of the bearings.

NOTE Scragging is exhibited by elastomeric bearings if they have been previously (i.e. before testing) subjected to one or more cycles of high shear deformation. Scragged bearings show a significant drop of the shear stiffness in subsequent cycles. It appears however that the original (virgin) shear stiffness of the bearings is practically recovered after a certain time (a few months). This effect is prominent mainly in high damping and in low shear modulus bearings and should be accounted for by using an appropriate range of design parameters (see **K.2.1** and **K.2.3.3 R4**).

(9) Lead Rubber Bearings (LRB) consist of low-damping elastomeric bearings with a cylindrical lead core. Yielding of the lead core provides such devices with substantial hysteretic behaviour. This hysteretic behaviour may be represented by the bilinear approximation shown in Figure 7.1 with the following parameters:

– Elastic stiffness:  $K_e = K_L + K_R$

where  $K_R$  and  $K_L$  are the shear stiffnesses of the elastomeric and lead parts of the device, respectively;

– Post-elastic stiffness:  $K_p = K_R$ ;

– Yield force:  $F_y = F_{Ly} (1 + K_R/K_L)$

where  $F_{Ly}$  is the yield force of the lead core.

NOTE 1: When  $K_R \ll K_L$ , then  $K_e \cong K_L$  and  $F_y \cong F_{Ly}$

NOTE 2: LRBs should be in accordance with EN pr15129:200X: Antiseismic Devices.

#### 7.5.2.3.4 Fluid viscous dampers

(1) The reaction of fluid viscous dampers is proportional to  $v^{\alpha_b}$ , where

$v = \dot{d}_b = \frac{d}{dt}(d_b)$  is the velocity of motion. This reaction is zero at the maximum displacement  $d_{\max} = d_{bd}$  and therefore does not contribute to the effective stiffness of the isolating system. The force-displacement relationship of a fluid viscous damper is shown in Figure 7.2 (for sinusoidal motion), depending on the value of the exponent  $\alpha_b$ .

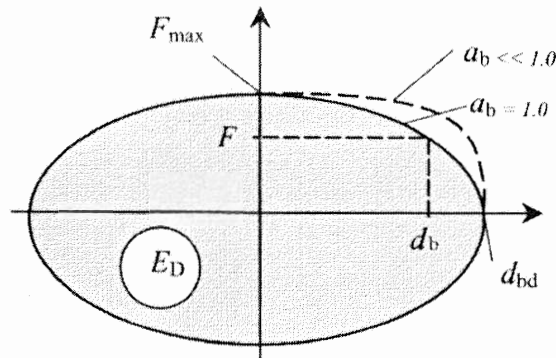

**Figure 7.2: Viscous force-displacement behaviour**

$$d_b = d_{bd} \sin(\omega t), \text{ with } \omega = 2\pi/T_{\text{eff}}$$

$$F = C v^{\alpha_b} = F_{\max} (\cos(\omega t))^{\alpha_b}$$

$$F_{\max} = C (d_{bd} \omega)^{\alpha_b}$$

$$E_D = \lambda(\alpha_b) F_{\max} d_{bd}$$

$$\lambda(\alpha_b) = 2^{2+\alpha_b} \frac{\Gamma^2(1+0,5\alpha_b)}{\Gamma(2+\alpha_b)}$$

$\Gamma()$  = is the gamma function

NOTE: In certain cases of viscous devices (fluid dampers) with low  $\alpha_b$ -values, combination of the viscous element with a linear spring in series (reflecting the fluid compressibility) is necessary to give satisfactory agreement of the force-velocity relationship with test results for  $E_D$ . However this has only minor influence on the energy ( $E_D$ ) dissipated by the device.

#### 7.5.2.3.5 Friction behaviour

(1) Sliding devices with a flat sliding surface limit the force transmitted to the superstructure to:

$$F_{\max} = \mu_d N_{Sd} \text{sign}(\dot{d}_b) \quad (7.1)$$

where:

$\mu_d$  is the dynamic friction coefficient

$N_{Sd}$  is the normal force through the device, and

$\text{sign}(\dot{d}_b)$  is the sign of the velocity vector  $\dot{d}_b$

$d_b$  is the relative displacement of the two sliding surfaces

Such devices however can result in substantial permanent displacements. Therefore they should be used in combination with devices providing adequate restoring capability (see 7.7.1).

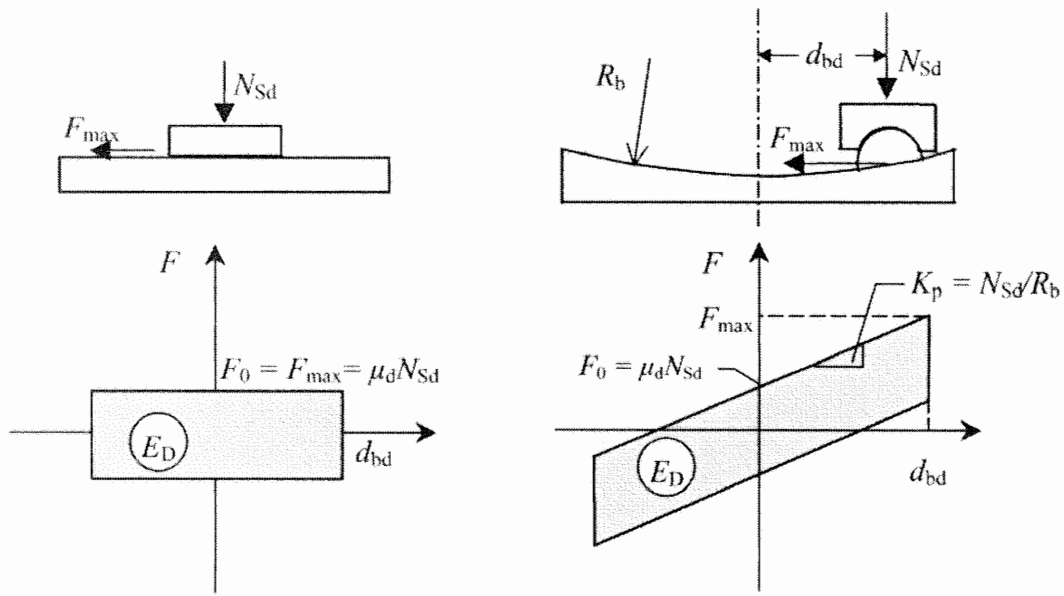

**Figure 7.3: Friction force-displacement behaviour**

(2) Sliding devices with a spherical sliding surface of radius  $R_b$  provide a restoring force at displacement  $d_b$  equal to  $N_{Sd}d_b/R_b$ . For such a device the force displacement relationship is:

$$F_{\max} = \frac{N_{Sd}}{R_b} d_{bd} + \mu_d N_{Sd} \text{sign}(\dot{d}_{bd}) \quad (7.2)$$

NOTE: Expression (7.2) offers sufficient approximation when  $d_b/R_b \leq 0,25$

(3) In both the above cases the energy dissipated per cycle  $E_D$  (see Figure 7.3), at the design displacement  $d_{bd}$  amounts to:

$$E_D = 4\mu_d N_{Sd} d_{bd} \quad (7.3)$$

(4) The dynamic friction coefficient  $\mu_d$  depends mainly on:

- the composition of the sliding surfaces;
- the use or not of lubrication;
- the bearing pressure on the sliding surface in the seismic design situation;
- the velocity of sliding



and should be determined by appropriate tests.

NOTE: Information on tests that may be used for the determination of the dynamic friction coefficient is given in Informative Annex K. It should be noted that for lubricated pure virgin PTFE that slides on polished stainless steel surface, the dynamic friction coefficient may be quite low ( $\leq 0,01$ ) at the range of velocities corresponding to seismic motions and under the usual range of bearing pressures on the sliding surface in the seismic design situation.

(5) Provided that the equivalent damping of the isolating system is assessed ignoring any contribution from these elements, sliding bearings with a lubricated PTFE flat sliding surface allowing sliding in both horizontal directions in accordance with EN 1337-2:2000 and elastomeric bearings with sliding lubricated PTFE elements allowing sliding in one horizontal direction, while in the other direction they behave as simple low damping elastomeric bearings, in accordance with EN 1337-2:2000 and EN 1337-3:2005, are not subject to special tests for seismic performance.

#### 7.5.2.4 Variability of properties of the isolator units

(1)P The nominal design properties (DP) of isolator units shall be validated in general in accordance with prEN15129:200X: Antiseismic Devices or be included in a ETA, with the exception of the special cases of simple low damping elastomeric bearings in accordance with 7.5.2.3.3(5) and 7.5.2.3.3(6), and of sliding bearings in accordance with 7.5.2.3.5(5), for which (4), (5) and (6) below apply.

NOTE See also Note under 7.5.2.1(1)P.

(2)P The nominal properties of the isolator units, and hence those of the isolating system, may be affected by ageing, temperature, loading history (scragging), contamination, and cumulative travel (wear). This variability shall be accounted for in accordance with Annex J, by using the following two sets of design properties of the isolating system, properly established,:

- Upper bound design properties (UBDP), and
- Lower bound design properties (LBDP).

(3)P In general and independently of the method of analysis, two analyses shall be performed: one using the UBDPs and leading to the maximum forces in the substructure and the deck, and another using the LBDPs and leading to the maximum displacements of the isolating system and the deck.

(4) Multi-mode spectrum analysis or Time-history analysis may be performed on the basis of the set of the nominal design properties, only if the design displacements  $d_{cd}$ , resulting from a Fundamental mode analysis, in accordance with 7.5.4, based on UBDPs and LBDPs, do not differ from that corresponding to the design properties by more than  $\pm 15\%$ .

$\boxed{A_1}$  (5) The nominal design properties of simple low-damping elastomeric bearings in accordance with 7.5.2.3.3(5) and (6), may be assumed as follows:  $\boxed{A_1}$

- Shear modulus  $G_b = \alpha G_g$

NOTE: The value of  $\alpha$  typically ranges from 1,1 to 1,4. The appropriate value is best determined by testing of the device.

– where  $G_g$  is the value of the “apparent conventional shear modulus” in accordance with EN 1337-3:2005;

– Equivalent viscous damping  $\xi_{\text{eff}} = 0,05$

(6) The variability of the design properties of simple low-damping elastomeric bearings, due to ageing and temperature, may be limited to the value of  $G_b$  and assumed as follows:

– LBDPs  $G_{b,\text{min}} = G_b$

– UBDPs depend on the “minimum bearing temperature for seismic design”  $T_{\text{min},b}$  (see **J.1(2)**) as follows:

- when  $T_{\text{min},b} \geq 0^\circ\text{C}$

**A1**

$G_{b,\text{max}} = 1,2 G_b$

- when  $T_{\text{min},b} < 0^\circ\text{C}$

the value of  $G_{b,\text{max}}$  should correspond to  $T_{\text{min},b}$ .

NOTE: In the absence of relevant test results, the  $G_{b,\text{max}}$  value for  $T_{\text{min},b} < 0^\circ\text{C}$  may be obtained from  $G_b$  adjusted regarding temperature and ageing in accordance with the  $\lambda_{\text{max}}$  values corresponding to  $K_p$ , specified in Tables JJ.1 and JJ.2. **A1**

(7) Values of friction parameters of the sliding elements whose contribution in the energy dissipation is ignored in accordance with **7.5.2.3.5(5)**, should be taken in accordance with EN 1337-2:2000.

### 7.5.3 Conditions for application of analysis methods

(1)P The Fundamental mode spectrum analysis may be applied if all of the following conditions are met:

a. The distance of the bridge site to the nearest known seismically active fault exceeds 10 km.

b. The ground conditions of the site correspond to one of the ground types A, B, C or E of EN 1998-1:2004, **3.1.1**.

c. The effective damping ratio does not exceed 0,30.

(2)P Multi-mode Spectrum Analysis may be applied if both conditions b and c of (1)P are met.

(3) Time-history non-linear analysis may be applied for the design of any isolated bridge.

### 7.5.4 Fundamental mode spectrum analysis

(1) The rigid deck model (see **4.2.2.3**) should be used in all cases.

(2)P The shear force transferred through the isolating interface in each principal direction shall be determined considering the superstructure as a single-degree-of-freedom system and using:

- the effective stiffness of the isolation system,  $K_{\text{eff}}$
- the effective damping of the isolation system,  $\zeta_{\text{eff}}$
- the mass of the superstructure,  $M_d$
- the spectral acceleration  $S_e(T_{\text{eff}}, \eta_{\text{eff}})$  (see EN 1998-1:2004, 3.2.2.2) corresponding to the effective period,  $T_{\text{eff}}$ , with  $\eta_{\text{eff}} = \eta(\zeta_{\text{eff}})$

The values of these parameters should be determined as follows:

- Effective stiffness

$$K_{\text{eff}} = \sum K_{\text{eff},i} \quad (7.4)$$

where  $K_{\text{eff},i}$  is the composite stiffness of the isolator unit and the corresponding substructure (pier)  $i$ .

- Effective damping

$$\zeta_{\text{eff}} = \frac{1}{2\pi} \left[ \frac{\sum E_{D,i}}{K_{\text{eff}} d_{\text{cd}}^2} \right] \quad (7.5)$$

where:

$\sum E_{D,i}$  is the sum of dissipated energies of all isolators  $i$  in a full deformation cycle at the design displacement  $d_{\text{cd}}$ .

- Effective Period

$$T_{\text{eff}} = 2\pi \sqrt{\frac{M_d}{K_{\text{eff}}}} \quad (7.6)$$

Ⓐ) (3) This leads to the results shown in Table 7.1 and Figure 7.4.

**Table 7.1: Spectral acceleration  $S_e$  and design displacement  $d_{\text{cd}}$**

$T_{\text{eff}}$	$S_e$	$d_{\text{cd}}$
$T_C \leq T_{\text{eff}} < T_D$	$2,5 \frac{T_C}{T_{\text{eff}}} a_g S \eta_{\text{eff}}$	$\frac{T_{\text{eff}}}{T_C} d_C$
$T_D \leq T_{\text{eff}} \leq 4 \text{ s}$	$2,5 \frac{T_C T_D}{T_{\text{eff}}^2} a_g S \eta_{\text{eff}}$	$\frac{T_D}{T_C} d_C$

where:

$$a_g = \gamma_1 a_{g,R} \quad (7.7)$$

and

$$d_C = \frac{0,625}{\pi^2} a_g S \eta_{\text{eff}} T_C^2 \quad (7.8) \quad \text{Ⓐ}$$

Ⓐ) The value of  $\eta_{\text{eff}}$  should be taken from the expression

$$\eta_{\text{eff}} = \sqrt{\frac{0,10}{0,05 + \zeta_{\text{eff}}}} \geq 0,40 \quad (7.9)$$

Maximum shear force

$$V_d = M_d S_e = K_{\text{eff}} d_{\text{cd}} \quad (7.10)$$

where:

$S_e$ ,  $T_C$  and  $T_D$  are parameters of the design spectrum depending on the ground type, in accordance with 7.4.1(1)P and EN 1998-1:2004, 3.2.2.2;

$a_g$  is the design ground acceleration on type A ground corresponding to the importance category of the bridge;

$\gamma_I$  is the importance factor of the bridge; and

$a_{g,R}$  is the reference design ground acceleration (corresponding to the reference return period).

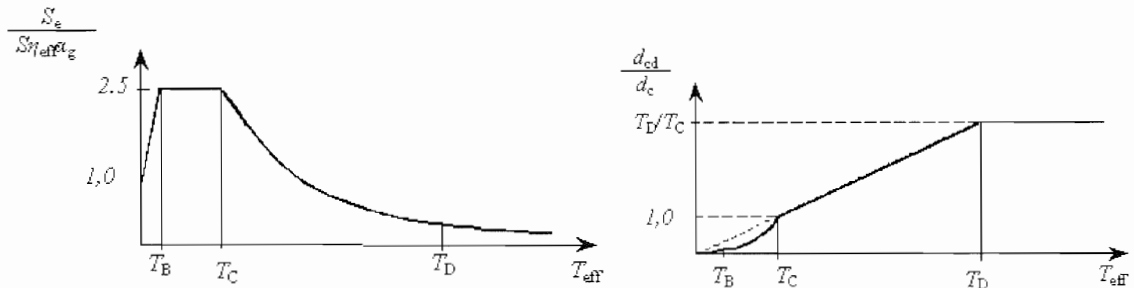

Figure 7.4: Acceleration and displacement spectra

NOTE 1: The elastic response spectrum in EN 1998-1:2004, 3.2.2.2(1)P applies up to periods of 4 s. For values of  $T_{\text{eff}}$  longer than 4 s the elastic displacement response spectrum in EN 1998-1:2004, Annex A may be used and the elastic acceleration response spectrum may be derived from the elastic displacement response spectrum by inverting expression (3.7) in EN 1998-1:2004. Nonetheless, isolated bridges with  $T_{\text{eff}} > 4$  s deserve special attention, due to their inherently low stiffness against any horizontal action.

NOTE 2: For a pier of height  $H_i$  with a displacement stiffness  $K_{si}$  (kN/m), supported by a foundation with translation stiffness  $K_{ti}$  (kN/m), rotation stiffness  $K_{fi}$  (kNm/rad), and carrying isolator unit  $i$  with effective stiffness  $K_{bi}$  (kN/m), the composite stiffness  $K_{\text{eff},i}$  is (see Figure 7.5N):

$$\frac{1}{K_{\text{eff},i}} = \frac{1}{K_{bi}} + \frac{1}{K_{ti}} + \frac{1}{K_{si}} + \frac{H_i^2}{K_{fi}} \quad (7.11N)$$

The flexibility of the isolator and its relative displacement  $d_{bi} = \frac{F}{K_{bi}}$  typically is much larger than the other components of the superstructure displacement. For this reason the effective damping of the system depends only on the sum of dissipated energies of the isolators,  $\Sigma E_{Di}$ , and the relative displacement of the isolator is practically equal to the displacement of the superstructure at this point ( $d_{bi}/d_{id} = K_{\text{eff},i}/K_{bi} \cong 1$ ). Ⓐ)

A1

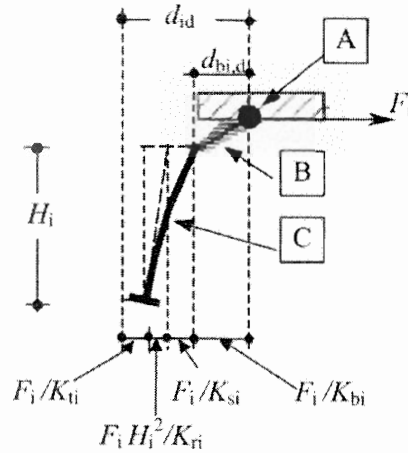

**Key**

A – Superstructure

B – Isolator *i*

C – Pier *i*

**Figure 7.5N: Composite stiffness of pier and *i* isolator** A1

(4) In essentially non-linear systems,  $K_{eff}$  and  $\zeta_{eff}$  depend on the design displacement  $d_{cd}$  (see  $d_{bd}$  in Figure 7.1). Successive approximations of  $d_{cd}$  should be performed to limit deviations between the assumed and calculated values within  $\pm 5\%$ .

(5) For the determination of the seismic action effects on the isolating system and the substructures in the principal transverse direction (let's say direction *y*), the influence of plan eccentricity in the longitudinal direction  $e_x$  (between the effective stiffness centre and the centre of mass of the deck) on the superstructure displacement  $d_{id}$  over pier *i*, should be evaluated as follows:

$$d_{id} = \delta_i d_{cd} \tag{7.12}$$

$$\delta_i = 1 + \frac{e_x}{r r_x} x_i \tag{7.13}$$

with:

$$r_x^2 = \frac{\Sigma(x_i^2 K_{yi} + y_i^2 K_{xi})}{\Sigma K_{yi}} \tag{7.14}$$

where:

$e_x$  is the eccentricity in the longitudinal direction;

$r$  is the radius of gyration of the deck mass about the vertical axis through its centre of mass;

$x_i$  and  $y_i$  are the coordinates of pier  $i$  relative to the effective stiffness center;

$K_{yi}$  and  $K_{xi}$  are the effective composite stiffnesses of isolator unit and pier  $i$ , in the  $y$  and  $x$  directions, respectively.

NOTE: In straight bridges usually  $y_i \ll x_i$ . In such cases the term  $y_i^2 K_{xi}$  in expression (7.14) may be omitted.

(6)P Subclause 4.2.1.4(2) shall be applied for the combination of components of the seismic action.

### 7.5.5 Multi-mode Spectrum Analysis

(1)P The modelling of the isolating system shall reflect with sufficient accuracy:

- the spatial distribution of the isolator units and the relevant overturning effects, and
- the translation in both horizontal directions and the rotation about the vertical axis of the superstructure.

(2)P The modelling of the superstructure shall reflect with sufficient accuracy its deformation in plan. Accidental mass eccentricity need not be considered.

(3) The modelling of the substructures should reflect with sufficient accuracy the distribution of their stiffness properties and at least the rotational stiffness of the foundation. When the pier has significant mass and height, or if it is immersed in water, its mass distribution should also be properly modelled.

(4) The effective damping given by expression (7.5) may be applied only to modes having periods higher than  $0,8T_{eff}$ . For all other modes, unless a more accurate estimation of the relevant damping ratio is made, the damping ratio corresponding to the structure without seismic isolation should be used.

(5)P Subclause 4.2.1.4(2) shall be applied for the combination of the horizontal components of the seismic action.

(6) The resulting displacement of the stiffness centre of the isolating system ( $d_{cd}$ ) and the resulting total shear force transferred through the isolation interface ( $V_d$ ) in each of the two-horizontal directions, are subject to lower bounds as follows:

$$\rho_d = \frac{d_{cd}}{d_{cf}} \geq 0,80 \quad (7.15)$$

$$\rho_v = \frac{V_d}{V_f} \geq 0,80 \quad (7.16)$$

where:

$d_{cf}$ ,  $V_f$  are respectively the design displacement and the shear force transferred through the isolation interface, calculated in accordance with the Fundamental mode spectrum analysis of 7.5.4. For the needs of the verification of expressions (7.15) and (7.16), the limitations of 7.5.3(1)P do not apply.

(7) In case the conditions in (6) are not met, the relevant effects on the isolation system, the deck and the substructures should be multiplied times:

$$\frac{0,80}{\rho_d} \text{ for the seismic displacements, or} \quad (7.17)$$

$$\frac{0,80}{\rho_v} \text{ for the seismic forces and moments} \quad (7.18)$$

(8) The limitations of (6) and the relevant corrections in (7), need not be applied if the bridge cannot be approximated (even crudely) as a single-degree-of-freedom model. Such cases may appear in:

- bridges with high piers, the mass of which has a significant influence on the displacement of the deck
- bridges with a substantial eccentricity  $e_x$  in the longitudinal direction between the centre of mass of the deck and the effective stiffness centre ( $e_x > 0,10L$ )

In such cases it is recommended that the limitations and corrections of (6) and (7) are applied in each direction to displacements and forces derived from the fundamental mode of the actual bridge model in the same direction.

### 7.5.6 Time history analysis

(1)P Subclauses 7.5.5(1)P, (2)P, (3), (6), (7)P and (8)P apply, using in expressions (7.15) and (7.16) as values of  $d_{cd}$  and  $V_d$  the corresponding design action effects in accordance with 4.2.4.3(1)P.

### 7.5.7 Vertical component of seismic action

(1) The effects of the vertical component of the seismic action may be determined by linear response spectrum analysis, regardless of the method used for the determination of the response to the horizontal seismic action. For the combination of the action effects 4.2.1.4 applies.

## 7.6 Verifications

### 7.6.1 Seismic design situation

(1)P The seismic design situation is described by expression (5.4) in 5.5(1)P.

(2)P The design seismic action effects for the isolating system shall be taken in accordance with 7.6.2 and those for the superstructure and substructure in accordance with 7.6.3.

### 7.6.2 Isolating system

**A1)** (1)P The required increased reliability of the isolating system (see 7.3(4)P) shall be implemented by designing each isolator  $i$  for increased design displacements  $d_{bi,a}$ : **A1**

$$\boxed{\text{A1}} \quad d_{\text{bi,a}} = \gamma_{\text{S}} d_{\text{bi,d}} \quad (7.19)$$

where  $\gamma_{\text{S}}$  is an amplification factor that is applied only on the design seismic displacement  $d_{\text{bi,d}}$  of each isolator  $i$  resulting from one of the procedures specified in 7.5.

If the spatial variability of the seismic action is accounted for through the simplified method of 3.3(4), (5), (6) and (7)P, the increased design displacements shall be estimated by application of the rule of 3.3(7)P, where the displacements  $d_{\text{bi,d}}$  due the inertia response determined in accordance with one of the methods in 7.5 shall be amplified in accordance with expression (7.19) above, while those corresponding to the spatial variability determined in accordance with 3.3.(5) and (6), need not be amplified.

NOTE The value ascribed to  $\gamma_{\text{S}}$  for use in a country may be defined in its National Annex. The recommended value is  $\gamma_{\text{S}} = 1,50$ .

(2)P The maximum total displacement of each isolator unit in each direction  $d_{\text{m,i}}$  shall be verified from expression (7.19a) by adding to the above increased design seismic displacement, the offset displacement  $d_{\text{G,i}}$  potentially induced by:

- a) the permanent actions;
- b) the long-term deformations (post-tensioning, shrinkage and creep for concrete decks) of the superstructure; and
- c) 50% of the thermal action.

$$d_{\text{m,i}} \geq d_{\text{G,i}} + d_{\text{bi,a}} \quad (7.19a)$$

NOTE An additional condition for the displacement capacity  $d_{\text{m,i}}$  of the isolators is given in 7.7.1(4).

(3)P All components of the isolating system shall be capable of functioning without significant change in isolation properties up to their displacement capacity  $d_{\text{m,i}}$  in the relevant direction.

(4)P The design resistance of each load-carrying member of the isolation system, including its anchorage, shall exceed the force acting on the member at the total maximum displacement. It shall also exceed the design force caused by wind loading of the structure in the relevant direction.

NOTE The maximum reaction of hydraulic viscous dampers (see 7.5.2.3.4) corresponding to the increased displacement  $d_{\text{bi,a}}$  may be estimated by multiplying the reaction resulting from the analysis times  $\gamma_{\text{IS}}^{\alpha_{\text{b}}/2}$ , with  $\alpha_{\text{b}}$  as defined in 7.5.2.3.4

(5) Isolator units consisting of simple low-damping elastomeric bearings should be verified for the action effects in (1)P to (4)P, in accordance with the relevant rules of EN 1337-3:2005 as follows. The maximum total design shear strain in the bearing should be calculated as the sum of

- a) the design shear strain due to vertical compression,
- b) the shear strain corresponding to the total design horizontal displacement and
- c) the shear strain corresponding to the total design angular rotation  $\boxed{\text{A1}}$



**A1)** of the bearing in the seismic design situation, without multiplication of this sum by an amplification factor. This strain should not exceed the value of  $\varepsilon_{u,d}$  according to relation (2) of 5.3.3 of EN 1337-3:2005. Buckling and sliding stability should be checked according to the relevant rules of 5.3.3.6 of EN 1337-3:2005.

NOTE The value ascribed to the partial factor  $\gamma_m$  in the relation for  $\varepsilon_{u,d}$  for use in a country for the calculation of the design resistance of simple low-damping elastomeric bearings in the seismic design situation may be specified in the National Annex of the country. The recommended value is  $\gamma_m = 1,00$ . **A1)**

(6) For simple low damping elastomeric bearings, in addition to the verification of (5), the following condition should be verified:

$$\varepsilon_{q,d} \leq 2,0 \quad (7.20)$$

where  $\varepsilon_{q,d}$  is the shear strain calculated in accordance with expression (10) in EN 1337-3:2005, **5.3.3.3**. In this context  $v_{x,d}$  and  $v_{y,d}$  should be taken equal to the maximum total relative displacements in the horizontal directions x and y, as specified in (2) above.

(7) No uplift of isolators carrying vertical force is allowed in the seismic design situation with the seismic action as specified by **7.4**.

(8) The sliding elements mentioned in **7.5.2.3.5(5)** should be designed in accordance with EN 1337-2:2000, for seismic design displacement in accordance with (1)P above.

### 7.6.3 Substructures and superstructure

(1)P The seismic internal forces  $E_{EA}$  in the substructures and superstructure due to the design seismic action alone, shall be derived from the results of an analysis in accordance with **7.5**.

(2) The design seismic forces  $E_E$  due to the design seismic action alone, may be derived from the forces  $E_{EA}$  of (1)P, after division by the  $q$ -factor corresponding to limited ductile/essentially elastic behaviour, i.e.  $F_E = F_{E,A}/q$  with  $q \leq 1,50$ .

(3) All members of the structure should be verified to have an essentially elastic behaviour in accordance with the rules of **5.6.2** and **6.5**.

(4)P Design action effects for the foundation shall be in accordance with **5.8.2(2)P**.

(5) The design horizontal forces of supporting members (piers or abutments) carrying sliding bearings described in **7.5.2.3.5(5)**, should be derived from the maximum friction values in accordance with the relevant provision of EN 1337-2:2000.

(6) In the case of (5) above and when the same supporting member also carries viscous fluid dampers, then:

(a) the design horizontal seismic force of the supporting member in the direction of the action of the damper should be increased by the maximum seismic force of the damper (see expression (7.21)).

(b) the design horizontal force of non-seismic design situations under imposed deformation actions (temperature variation) should be increased by the damper reaction, estimated as 10% of the maximum seismic force of the damper, used in (a) above.

(7) When single or multiple mode spectral analysis is carried out for isolating systems consisting of combination of elastomeric bearings and fluid viscous dampers supported on the same supporting element(s), the phase difference between the maxima of the elastic and the viscous elements may be taken into account, by the following approximation. The seismic forces should be determined as the most adverse of those corresponding to the following characteristic states:

a. At the state of maximum displacement, as given by expression (7.10). The damper forces are then equal to zero.

b. At the state of maximum velocity and zero displacement, when the maximum damper forces should be determined by assuming the maximum velocity to be:

$$v_{\max} = 2\pi d_{bd}/T_{\text{eff}} \quad (7.21)$$

where  $d_{bd}$  is the maximum damper displacement corresponding to the design displacement  $d_{cd}$  of the isolating system.

c. At the state of the maximum inertial force on the superstructure, that should be estimated as follows:

$$F_{\max} = (f_1 + 2\zeta_b f_2) S_e M_d \quad (7.22)$$

where  $S_e$  is determined from Table 7.1 with  $K_{\text{eff}}$  in accordance with expression (7.4), without any stiffness contribution from the dampers, and

$$f_1 = \cos[\arctan(2\zeta_b)] \quad (7.23a)$$

$$f_2 = \sin[\arctan(2\zeta_b)] \quad (7.23b)$$

where  $\zeta_b$  is the contribution of the dampers to the effective damping  $\zeta_{\text{eff}}$  of expression (7.5).

At this state the displacement amounts to  $f_1 d_{cd}$  and the velocity of the dampers to  $v = f_2 v_{\max}$

(8) In isolating systems consisting of a combination of fluid viscous dampers and elastomeric bearings, as in the case of (7), without sliding elements, the design horizontal force acting on supporting element(s) that carry both bearings and dampers, for non-seismic situations of imposed deformation actions (temperature variation, etc.) should be determined by assuming that the damper reactions are zero.

## 7.7 Special requirements for the isolating system

### 7.7.1 Lateral restoring capability

(1)P The isolating system shall present self-restoring capability in both principal horizontal directions, to prevent cumulative build-up of displacements. This capability is available when the system has small residual displacements in relation to its displacement capacity  $d_m$ . A1

- Ⓐ<sub>1</sub> (2) The requirements in (1)P are considered to be satisfied in a direction when the displacement  $d_0$  as defined below meets the following condition in the examined direction:

$$\frac{d_{cd}}{d_0} \geq \delta \quad (7.24)$$

where:

$d_{cd}$  is the design displacement of the isolating system in the examined direction, as defined in 7.2,

$d_0$  is the maximum residual displacement for which the isolating system can be in static equilibrium in the considered direction using system properties as defined in this paragraph and in (5) below. Thereby no account should be taken of any limitation due to the displacement capacity of the isolators (unlimited capacity). For systems with bilinear behaviour, according to 7.5.2.3.2 or systems that can be approximated as such,  $d_0$  is given as:

$$d_0 = F_0 / K_p \quad (7.25)$$

$\delta$  is a numerical value

NOTE 1: The value of ratio  $\delta$  for use in a country may be found in its National Annex. The recommended value is  $\delta = 0,50$  (see also Figure 7.8 and 7.7.1(4) Note 2).

NOTE 2: For systems that are approximated by bilinear hysteretic behaviour (see Figure 7.6N) the properties of the equivalent bilinear system should be determined as follows: The force value at zero displacement  $F_0$  and an estimated value of the design displacement  $d_{cd}$  are maintained. The straight lines for the loading branch AB and the unloading branch BC are defined so as to approximate the corresponding branches of the actual loop on an equal area basis.

NOTE 3: For systems with bilinear behaviour according to 7.5.2.3.2, or systems that can be approximated as such, the displacement  $d_0 = F_0 / K_p$  depends on properties of the isolating system considered independently from its displacement capacity. Therefore in Figure 7.6N the systems with the loops ABCD and AB'C'D have the same  $d_0$ . The value of  $d_0$  is positive when the post-elastic stiffness  $K_p$  is positive, negative when  $K_p$  is negative, and  $\infty$  when  $K_p$  is zero. Systems with negative  $K_p$  should not be used.

NOTE 4: For systems of sliding devices with spherical sliding surface (see 7.5.2.3.5(2))  $d_0 = \mu_d R_b$ .

NOTE 5: For systems with hysteretic behaviour that cannot be approximated by a bilinear relationship (see Figure 7.7N) the value of  $d_0$  may be defined from the intersection of the post-elastic branches with the displacement axis. The yield displacement  $d_y$  may be assumed equal to zero, for increased reliability. Ⓐ<sub>1</sub>

A1

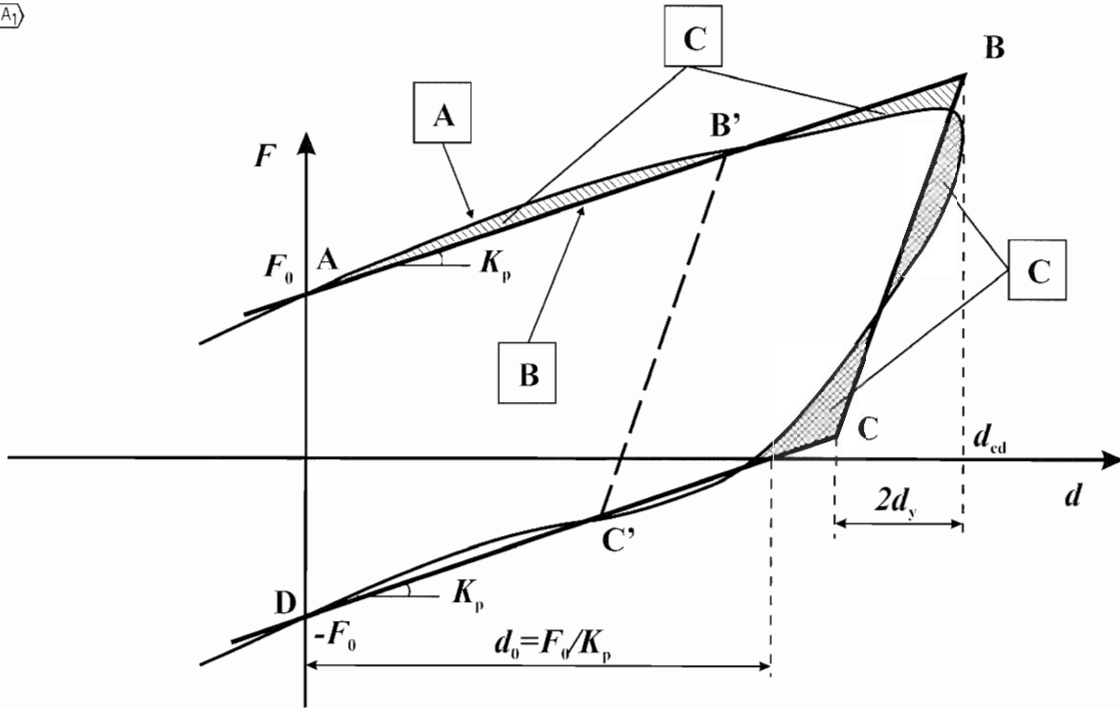

**Key**

$F$  – Force

$d$  – Displacement

A – Actual force-displacement relation

B – Approximation by bilinear model (ABCD)

C – Equal areas

**Figure 7.6N: Definition of the equivalent bilinear model for the evaluation of restoring capability** A1

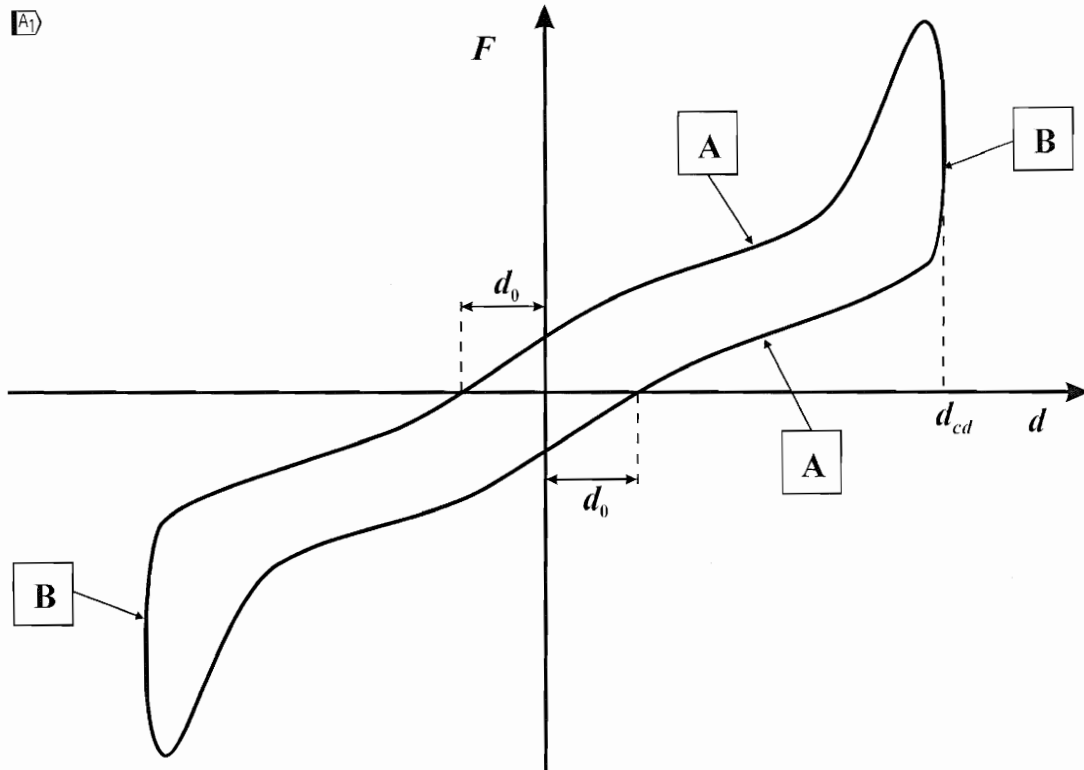

**Key**

$F$  – Force

$d$  – Displacement

**A** – Post-elastic branch

**B** – Elastic branch

**Figure 7.7N: Hysteretic systems that cannot be approximated by a bilinear model**

(3) Systems that do not satisfy condition (7.24) in a certain direction may be considered to meet the requirements of **1(P)** if they have sufficient displacement capacity in order to accommodate, with adequate reliability, the accumulation of residual displacements in this direction during the service life of the structure.

(4) The condition in (3) is considered to be met when the following relation is satisfied for every isolator:

$$d_{m,i} \geq d_{G,i} + \gamma_{du} d_{bi,d} \rho_d \tag{7.26a}$$

$$\text{where: } \rho_d = 1 + 1,35 \frac{1 - (d_y / d_{cd})^{0,6}}{1 + 80(d_{cd} / d_0)^{1,5}} \tag{7.26b}$$

and is depicted in Figure 7.8

and

$d_{m,i}$  is the displacement capacity of the isolator  $i$  in the considered direction, i.e. the maximum displacement that the isolator can accommodate in this direction, **A1**

- $d_{bi,d}$  is the design displacement of isolator  $i$  in the examined direction, as defined in 7.6.2(1)P,
- $d_{G,i}$  is the non-seismic offset displacement of isolator  $i$  according to 7.6.2(2)P,
- $d_y$  is the yield displacement of the equivalent bilinear system that is determined in accordance to (2) above. For sliding systems  $d_y$  can be assumed zero. When uncertainties regarding the magnitude of  $d_y$  are present it should be assumed zero.
- $\gamma_{du}$  is a numerical coefficient reflecting uncertainties in the estimation of design displacements.

NOTE 1: The value ascribed to  $\gamma_{du}$  for use in a country may be found in its National Annex. The recommended value is:  $\gamma_{du} = 1,20$ .

NOTE 2: The second term in the expression for  $\rho_d$  in (7.26b) reflects the accumulation of residual displacements under a sequence of earthquake events occurring before the design earthquake, considered to have a collective probability equal to the probability of the design earthquake. For systems with  $d_{cd}/d_0 \geq 0,50$ , the accumulation of residual displacements is insignificant (see Figure 7.8). For systems with  $d_{cd}/d_0 < \delta$  the maximum  $d_{m,i}$  value should be derived either from expression (7.26a) or from expression (7.19a), whichever gives the greater value.

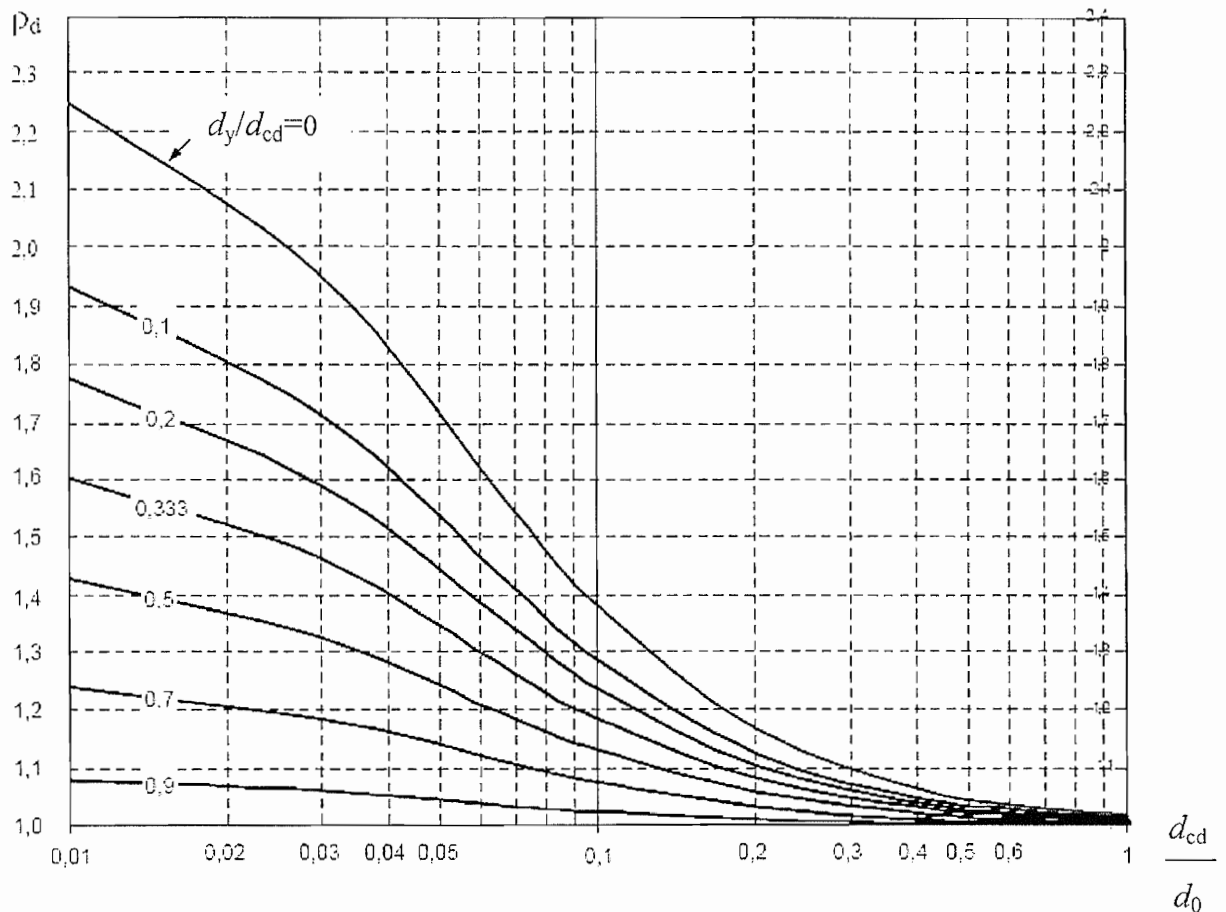

Figure 7.8: Plot of  $\rho_d$  according to expression (7.26b)

(5) The same properties of the isolators under dynamic conditions should be used for the estimation of both  $d_{cd}$  and  $d_0$ . The lateral restoring conditions (7.24) and (7.26) do not account for effects of velocity variation on the forces of isolators.  $\square$

### 7.7.2 Lateral restraint at the isolation interface

(1)P The isolating system shall provide sufficient lateral restraint at the isolation interface to satisfy any relevant requirements of other Eurocodes or Standards regarding limitation of displacements/deformations under serviceability criteria.

NOTE This requirement is usually critical for braking action in railway bridges.

(2) When sacrificial bracings (a fuse system) are used at certain support(s) in the final bridge system for implementing serviceability displacement restraints between the deck and substructures, their yield capacity should not exceed 40% of the design seismic force transferred through the isolation interface of the isolated structure, at the same support and direction. If this requirement is not met, the serviceability state requirements (except fatigue) of the relevant material Eurocodes (EN 1992-2:2005, EN 1993-2:2005 or EN 1994-2:2005) should be satisfied for the members of the bridge structure, under the loading for which the restraining bracing is designed, when this loading is increased so that the relevant reaction reaches the yield capacity of the bracing.

NOTE: prEN 15129:200X, Section 5, gives specifications for rigid connection devices that can be used to provide lateral restraint at the isolation interface.

(3) When shock transmission units with force limiting function (see 6.6.3.3) are used for implementing serviceability displacement restraints, the shock transmission units should be included in the model, in the verifications and in the testing procedure of the isolating system.

### 7.7.3 Inspection and Maintenance

(1)P All isolator units shall be accessible for inspection and maintenance.

(2)P An inspection and maintenance programme for the isolating system and all components crossing the isolation interface shall be prepared.

(3)P Repair, replacement or retrofitting of any isolator unit or component crossing the isolation interface shall be performed under the direction of the entity responsible for the maintenance of the bridge, and shall be recorded in detail in a relevant report.

**ANNEX A (Informative)**  
**PROBABILITIES RELATED TO THE REFERENCE SEISMIC ACTION.**  
**GUIDANCE FOR THE SELECTION OF DESIGN SEISMIC ACTION**  
**DURING THE CONSTRUCTION PHASE**

**A.1 Reference seismic action**

(1) The reference seismic action can be defined by selecting an acceptably low probability ( $p$ ) of it being exceeded within the design life ( $t_L$ ) of the structure. Then the return period of the event ( $T_R$ ) is given by the expression:

$$T_R = 1/(1 - (1 - p)^{1/t_L}) \quad (\text{A.1})$$

(2) The reference seismic action (corresponding to  $\gamma_1 = 1,0$ ) usually reflects a seismic event with a reference return period,  $T_{NCR}$ , of 475 years. Such an event has a probability of exceedance between 0,10 and 0,19 for a design life ranging between 50 and 100 years respectively. This level of design action is applicable to the majority of the bridges considered to be of average importance.

**A.2 Design seismic action for the construction phase**

(1) Assuming that  $t_c$  is the duration of the construction phase of a bridge and  $p$  is the acceptable probability of exceedance of the design seismic event during this phase, the return period  $T_{Rc}$  is given by expression (A.1), using  $t_c$  instead of  $t_L$ . For the relatively small values usually associated with  $t_c$  ( $t_c \leq 5$  years), expression (A.1) may be approximated by the following simpler relationship:

$$T_{Rc} \cong \frac{t_c}{p} \quad (\text{A.2})$$

It is recommended that the value of  $p$  does not exceed 0,05.

(2) The value of the design ground acceleration  $a_{gc}$  corresponding to a return period  $T_{Rc}$ , depends on the seismicity of the region. In many cases the following relationship offers an acceptable approximation

$$\frac{a_{gc}}{a_{g,R}} = \left( \frac{T_{Rc}}{T_{NCR}} \right)^k \quad (\text{A.3})$$

where:

$a_{g,R}$  is the reference peak ground acceleration corresponding to the reference return period  $T_{NCR}$ .

The value of the exponent  $k$  depends on the seismicity of the region. Normally, values in the range of 0,30 – 0,40 may be used.

(3) The robustness of all partial bridge structures should be ensured during the construction phases independently of the design seismic actions.



**ANNEX B(INFORMATIVE)**  
**RELATIONSHIP BETWEEN DISPLACEMENT DUCTILITY AND**  
**CURVATURE DUCTILITY FACTORS OF PLASTIC HINGES IN**  
**CONCRETE PIERS**

(1) Assuming that:

- the horizontal displacement at the centre of mass of the deck is due only to the deformation of a fully fixed cantilever pier of length  $L$ , that
- the mass of the pier is negligible compared to that of the deck, and that
- $L_p$  is the length of the plastic hinge developing at the base of the pier,

the required curvature ductility factor  $\mu_{\Phi}$  of the hinge corresponding to a structure displacement ductility factor  $\mu_d$ , as defined in 2.3.5.2, is:

$$\mu_{\Phi} = \frac{\Phi_u}{\Phi_y} = 1 + \frac{\mu_d - 1}{3\lambda(1 - 0,5\lambda)} \quad (\text{B.1})$$

where:  $\lambda = L_p/L$

(2) In reinforced concrete sections (where the curvature ductility factor is used as a measure of the ductility of the plastic hinge), the value of the ratio  $\lambda$  is influenced by such effects as the reinforcement tensile strain penetration in the adjoining member, the inclined cracking due to shear-flexure interaction etc. The value of  $L_p$  in accordance with E.3.2(5) may be used.

(3) When a considerable part of the deck displacement is due to the deformation of other components which remain elastic after the formation of the plastic hinge, the required curvature ductility factor  $\mu_{\Phi d}$  is given by the expression

$$\mu_{\Phi d} = 1 + f(\mu_{\Phi} - 1) \quad (\text{B.2})$$

where:

$f = d_{\text{tot}}/d_p$  is the ratio of the total deck displacement  $d_{\text{tot}}$  to the displacement  $d_p$ , due to the deformation of the pier only, and

$\mu_{\Phi}$  is calculated from expression (B.1).

NOTE: If the seismic action is transferred between deck and pier through flexible elastomeric bearings inducing for example a value of  $f = 5$  and assuming that for example  $\mu_{\Phi} = 15$ , would be required in the case of rigid connection between the deck and the pier, the required value of  $\mu_{\Phi d}$  in accordance with equation (B.2) amounts to 71, which is certainly not available. It is therefore evident that the high flexibility of the elastomeric bearings, used in the same force path with the stiff pier, imposes a practically elastic overall behaviour of the system.

## ANNEX C (INFORMATIVE)

### ESTIMATION OF THE EFFECTIVE STIFFNESS OF REINFORCED CONCRETE DUCTILE MEMBERS

#### C.1 General

(1) The effective stiffness of ductile concrete components used in linear seismic analysis should be equal to the secant stiffness at the theoretical yield point. Unless otherwise substantiated by calculation, one of the following approximate methods may be used to determine the secant stiffness at the theoretical yield point:

#### C.2 Method 1

(1) The effective moment of inertia  $J_{\text{eff}}$  of a pier of constant cross section may be estimated as follows:

$$J_{\text{eff}} = 0,08 J_{\text{un}} + J_{\text{cr}} \quad (\text{C.1})$$

where:

$J_{\text{un}}$  is the moment of inertia of the gross section of the uncracked pier;

$J_{\text{cr}}$  is the moment of inertia of the cracked section at the yield point of the tensile reinforcement. This may be estimated from the expression:

$$J_{\text{cr}} = M_y / (E_c \cdot \Phi_y) \quad (\text{C.2})$$

in which  $M_y$  and  $\Phi_y$  are the yield moment and curvature of the section respectively and  $E_c$  is the elastic modulus of concrete.

(2) These expressions have been derived from a parametric analysis of a simplified non-linear model of a cantilever pier with hollow rectangular and hollow and solid circular cross-sections.

#### C.3 Method 2

(1) The effective stiffness may be estimated from the design ultimate moment  $M_{\text{Rd}}$  and the yield curvature  $\Phi_y$  of the plastic hinge section as follows:

$$E_c J_{\text{eff}} = \nu M_{\text{Rd}} / \Phi_y \quad (\text{C.3})$$

where:

$\nu = 1,20$  is a correction coefficient reflecting the stiffening effect of the uncracked part of the pier.

The curvature at yield  $\Phi_y$  may be determined as follows:

$$\Phi_y = (\varepsilon_{\text{sy}} - \varepsilon_{\text{cy}}) / d_s \quad (\text{C.4})$$

and

- $d_s$  is the depth of the section to the centre of the tension reinforcement  
 $\varepsilon_{sy}$  is the yield strain of the reinforcement,  
 $\varepsilon_{cy}$  is the compressive strain of concrete at yielding of the tension reinforcement.

The value of  $\varepsilon_{cy}$  may be estimated by a section analysis on the basis of  $\varepsilon_{sy}$  and the actual force in the seismic design situation,  $N_{Ed}$ .

(2) The assumptions of the following value for the yield curvature:

$$\text{for rectangular sections: } \Phi_y = 2,1 \varepsilon_{sy}/d \quad (\text{C.5})$$

$$\text{and for circular sections: } \Phi_y = 2,4 \varepsilon_{sy}/d \quad (\text{C.6})$$

where  $d$  is the effective depth of the section, give in general satisfactory approximation.

(3) The analysis performed on the basis of a value of  $E_c J_{eff}$  based on an assumed value of  $M_{Rd}$  needs to be corrected only if the finally required value of flexural capacity,  $M_{Rd,req}$  is significantly higher than the assumed value  $M_{Rd}$ . If  $M_{Rd,req} < M_{Rd}$ , the correction may just entail multiplication of the displacements resulting from the first analysis times the ratio  $M_{Rd}/M_{Rd,req}$ .

**ANNEX D (INFORMATIVE)**  
**SPATIAL VARIABILITY OF EARTHQUAKE GROUND MOTION:**  
**MODEL AND METHODS OF ANALYSIS**

**D.1 Description of the model**

(1) Spatial variability can be described by means of a vector of zero-mean random processes. Under the assumption of stationarity, this vector is fully defined by means of its symmetric  $n \times n$  matrix of auto- and cross-power spectral density functions:

$$G(\omega) = \begin{bmatrix} G_{11}(\omega) & G_{12}(\omega) & \dots & G_{1n}(\omega) \\ & G_{22}(\omega) & \dots & G_{2n}(\omega) \\ & & \dots & \dots \\ & & & G_{nn}(\omega) \end{bmatrix} \quad (\text{D.1})$$

where  $n$  is the number of supports.

It is useful to introduce the following non-dimensional complex-valued function, called *coherency function*:

$$\gamma_{ij}(\omega) = \frac{G_{ij}(\omega)}{\sqrt{G_{ii}(\omega)G_{jj}(\omega)}} \quad (\text{D.2})$$

Its modulus is bounded by 0 and 1,0 and provides a measure of the linear statistical dependence of the two processes at the supports  $i$  and  $j$ , whose distance is  $d_{ij}$ .

(2) The following form of the coherency function is frequently referred to [1][2]:

$$\gamma_{ij}(\omega) = \gamma_{ij,1}(\omega) \cdot \gamma_{ij,2}(\omega) \cdot \gamma_{ij,3}(\omega) = \exp\left[-\left(\frac{\alpha\omega d_{ij}}{v_s}\right)^2\right] \cdot \exp\left[i\frac{\omega d_{ij}^L}{v_{app}}\right] \cdot \exp[i\theta_{ij}(\omega)] \quad (\text{D.3})$$

where:

$v_s$  is the shear-wave velocity,

$\alpha$  is a constant,

$v_{app}$  is the so-called apparent velocity of waves,

$d_{ij}^L$  is the distance between supports  $i$  and  $j$  projected along the direction of propagation of the waves, and

$\theta_{ij}(\omega)$  is a frequency-dependent phase angle.

(3) The factors  $\gamma_{ij,1}(\omega)$ ,  $\gamma_{ij,2}(\omega)$  and  $\gamma_{ij,3}(\omega)$  account for the loss of correlation due to reflections/refractions in the propagation medium, for the finiteness of the propagation velocity of the waves and their angle of incidence at the surface and for the different soil conditions at the two supports, respectively. The difference of the soil properties at

two supports is taken into account in the model by considering two soil columns representing the two soil profiles acted upon at their base by a stationary white noise of intensity  $G_0$ . The soil columns are characterised by transfer functions  $H_i(\omega)$  and  $H_j(\omega)$ , respectively, which are such as to provide the desired spectral content and intensity of the motion at the upper surface in locations  $i$  and  $j$

$$G_{ij}(\omega) = G_0 |H_i(\omega)|^2 \quad (D.4)$$

(4)P The power density spectrum at the site shall be consistent with the elastic response spectrum as given in EN 1998-1: 2004, **3.2.2.2**.

It can also be shown that:

$$\theta_{ij}(\omega) = \tan^{-1} \left\{ \frac{\text{Im}[H_i(\omega)H_j(-\omega)]}{\text{Re}[H_i(\omega)H_j(-\omega)]} \right\} \quad (D.5)$$

## D.2 Generation of samples

(1) For the purposes of structural analysis samples of the vector of random processes described in **D.1** may need to be derived. To this end the matrix  $\mathbf{G}(\omega)$  is first decomposed into the product:

$$\mathbf{G}(\omega) = \mathbf{L}(\omega)\mathbf{L}^{*T}(\omega) \quad (D.6)$$

between matrix  $\mathbf{L}(\omega)$  and the transpose of its complex conjugate. If Cholesky decomposition is employed  $\mathbf{L}(\omega)$  is a lower triangular matrix.

According to [3] a sample of the acceleration motion at the generic support  $i$  is obtained from the series:

$$a_i(t) = 2 \sum_{j=1}^i \sum_{k=1}^N |L_{ij}(\omega_k)| \sqrt{\Delta\omega} \cos[\omega_k t - \theta_{ij}(\omega_k) + \phi_{jk}] \quad (D.7)$$

where:

$N$  is the total number of frequencies  $\omega_k$  into which the significant bandwidth of  $L_{ij}(\omega)$  is discretised;

$\Delta\omega = \omega_{\max}/N$ , and the angles  $\phi_{jk}$  are, for any  $j$ , a set of  $N$  independent random variables uniformly distributed between zero and  $2\pi$ .

Samples generated according to Expression (D.7) are characterised by the desired local frequency content as well as the assigned degree of correlation.

### **D.3 Methods of analysis**

#### **D.3.1 General**

(1) Based on **D.1** and **D.2**, the options described in **D.3.2** to **D.3.4** are available for determining the structural response to spatially varying ground motions.

#### **D.3.2 Linear random vibration analysis**

(1) A linear random vibration analysis is performed, using either modal analysis of frequency-dependent transfer matrices and input given by the matrix  $\mathbf{G}(\omega)$ .

(2) The elastic action effects are assumed as the mean values from the probability distribution of the largest extreme value of the response for the duration consistent with the seismic event underlying the establishment of  $a_g$ .

(3) The design values are determined by dividing the elastic effects by the appropriate behaviour factor  $q$  and ductile response is assured by conformity to the relevant rules of the normative part of this Standard.

#### **D.3.3 Time history analysis with samples of correlated motions**

(1) Linear time-history analysis can be performed using sample motions generated as indicated in **D.2**, starting from power spectra consistent with the elastic response spectra at the supports.

(2) The number of samples used should be such as to yield stable estimates of the mean of the maximum responses of interest. The elastic action effects are assumed as the mean values of the above maxima. The design values are determined by dividing the elastic action effects by the appropriate behaviour factor  $q$  and ductile response is assured by conformity to the relevant rules of the normative part of this Standard.

(3) Non-linear time-history analysis may be performed using sample motions generated as indicated in **D.2** starting from power spectra consistent with the elastic response spectra at the supports. The number of samples used should be such as to yield stable estimates of the mean of the maximum responses of interest.

(4) The design values of the action effects  $E_d$  are assumed as the mean values of the above maxima. The comparison between action effect  $E_d$  and design resistance  $R_d$  is to be performed in accordance with EN 1998-1:2004.

#### **D.3.4 Response spectrum for multiple-support input**

##### **D.3.4.1 General**

(1) A solution for the elastic response of a structure subjected to multiple support input in terms of response spectra has been derived in [4]. An outline is given here. For complete information refer to [4].

**D.3.4.2 Linear response to multiple-support input**

(1) The equations of motion for a discretised,  $n$ -degrees of freedom linear system subjected to  $m$  support motions can be written as:

$$\begin{bmatrix} \mathbf{M} & \mathbf{M}_c \\ \mathbf{M}_c^T & \mathbf{M}_g \end{bmatrix} \begin{bmatrix} \ddot{\mathbf{x}} \\ \ddot{\mathbf{u}} \end{bmatrix} + \begin{bmatrix} \mathbf{C} & \mathbf{C}_c \\ \mathbf{C}_c^T & \mathbf{C}_g \end{bmatrix} \begin{bmatrix} \dot{\mathbf{x}} \\ \dot{\mathbf{u}} \end{bmatrix} + \begin{bmatrix} \mathbf{K} & \mathbf{K}_c \\ \mathbf{K}_c^T & \mathbf{K}_g \end{bmatrix} \begin{bmatrix} \mathbf{x} \\ \mathbf{u} \end{bmatrix} = \begin{bmatrix} \mathbf{0} \\ \mathbf{F} \end{bmatrix} \quad (\text{D.8})$$

where:

$\mathbf{x}$  is the  $n$ -vector of the total displacements at the unconstrained degrees of freedom;

$\mathbf{u}$  is the  $m$ -vector of prescribed support displacements;

$\mathbf{M}$ ,  $\mathbf{C}$  and  $\mathbf{K}$  are the  $n \times n$  mass, damping and stiffness matrices associated with the unconstrained degrees of freedom, respectively;

$\mathbf{M}_g$ ,  $\mathbf{C}_g$  and  $\mathbf{K}_g$  are the  $m \times m$  mass, damping and stiffness matrices associated with the support degrees of freedom, respectively;

$\mathbf{M}_c$ ,  $\mathbf{C}_c$  and  $\mathbf{K}_c$  are the  $n \times m$  coupling matrices; and

$\mathbf{F}$  is the  $m$ -vector of the reacting forces at the support degrees of freedom.

(2) The total response is decomposed as:

$$\mathbf{x} = \mathbf{x}^s + \mathbf{x}^d \quad (\text{D.9})$$

where  $\mathbf{x}^s$ , called pseudo-static component, is the solution of expression (D.8) without the inertia and damping terms, i.e.:

$$\mathbf{x}^s = -\mathbf{K}^{-1} \mathbf{K}_c \mathbf{u} = \mathbf{R} \mathbf{u} \quad (\text{D.10})$$

Substituting expression (D.9) and (D.10) into expression (D.8), the differential equation for the dynamic component is obtained in the form:

$$\mathbf{M} \ddot{\mathbf{x}}^d + \mathbf{C} \dot{\mathbf{x}}^d + \mathbf{K} \mathbf{x}^d \cong -(\mathbf{M} \mathbf{R} + \mathbf{M}_c) \ddot{\mathbf{u}} \quad (\text{D.11})$$

after eliminating the comparatively negligible term  $-(\mathbf{C} \mathbf{R} + \mathbf{C}_c) \dot{\mathbf{u}}$ .

(3) Let  $\Phi$ ,  $\omega_i$  and  $\xi_i$  be the matrix of modal shapes, the modal frequencies and corresponding damping ratios of the fixed base structure. Setting  $\mathbf{x}^d = \Phi \mathbf{y}$  in Expression (D.11), the uncoupled modal equations are obtained as:

$$\ddot{y}_i + 2\xi_i \omega_i \dot{y}_i + \omega_i^2 y_i = \sum_{k=1}^m \beta_{ki} \ddot{u}_k(t) \quad i = 1, \dots, n \quad (\text{D.12})$$

where the modal participation factor has the form:

$$\beta_{ki} = \frac{\boldsymbol{\varphi}_i^T (\mathbf{M} \mathbf{r}_k + \mathbf{M}_c \mathbf{i}_k)}{\boldsymbol{\varphi}_i^T \mathbf{M} \boldsymbol{\varphi}_i} \quad (\text{D.13})$$

in which  $\mathbf{r}_k$  is the  $k$ -th column of  $\mathbf{R}$  and  $\mathbf{i}_k$  is the  $k$ -th column of a  $n \times n$  identity matrix.

(4) It is convenient to define a normalised modal response  $s_{ki}(t)$ , representing the response of a single-degree-of-freedom oscillator with frequency and damping ratio of the  $i$ -th mode, and subjected to the base acceleration  $\ddot{u}_k(t)$ :

$$\ddot{s}_{ki} + 2\xi_i \omega_i \dot{s}_{ki} + \omega_i^2 s_{ki} = \ddot{u}_k(t) \quad (\text{D.14})$$

Clearly one has:

$$y_i(t) = \sum_{k=1}^m \beta_{ki} s_{ki}(t) \quad (\text{D.15})$$

(5) A generic response quantity of interest  $z(t)$  (nodal displacement, internal force, etc) can be expressed as a linear function of the nodal displacement  $\mathbf{x}(t)$ :

$$z(t) = \mathbf{q}^T \mathbf{x}(t) = \mathbf{q}^T [\mathbf{x}^s(t) + \mathbf{x}^d(t)] \quad (\text{D.16})$$

Substituting for the expressions obtained for  $\mathbf{x}^s$  and  $\mathbf{x}^d$  one arrives at:

$$z(t) = \sum_{k=1}^m a_k u_k(t) + \sum_{k=1}^m \sum_{i=1}^n b_{ki} s_{ki}(t) \quad (\text{D.17})$$

in which:

$$a_k(t) = \mathbf{q}^T \mathbf{r}_k \quad b_{ki} = \mathbf{q}^T \boldsymbol{\varphi}_i \beta_{ki} \quad (\text{D.18})$$

### D.3.4.3 Response spectrum solution

(1) Using basic random vibration theory in conjunction with a model such as that described in **D.1** for the support motions  $\mathbf{u}(t)$ , the standard deviation of the response quantity of interest  $z(t)$  can be directly determined in terms of the standard deviations of the input processes  $\mathbf{u}(t)$  and of the normalised modal responses  $\mathbf{s}(t)$ , as well as of the correlation between input and output quantities.

(2) Further, by taking into account the relationship between the power spectral densities of the input processes,  $\mathbf{G}_{\ddot{\mathbf{u}}\ddot{\mathbf{u}}}(\omega)$ <sup>5</sup>, and the above standard deviations and correlations, as well as the relationships between power spectral density of the response

<sup>5</sup>  $\mathbf{G}_{\ddot{\mathbf{u}}\ddot{\mathbf{u}}}(\omega)$  denotes the power spectral densities matrix of the ground acceleration processes which, for simplicity of notation, is denoted in D.1 simply by  $\mathbf{G}(\omega)$ .



process and response spectrum, the following expression is derived for the mean value of the maximum response (i.e. the elastic action effect)<sup>6</sup>:

$$\mu_{z_{\max}} = \sqrt{\sum_{k=1}^m \sum_{l=1}^m a_k a_l \rho_{u_k u_l} u_{k,\max} u_{l,\max} + \sum_{k=1}^m \sum_{l=1}^m \sum_{i=1}^n \sum_{j=1}^n b_{ki} b_{lj} \rho_{s_{ki} s_{lj}} D_k(\omega_i, \xi_i) D_l(\omega_j, \xi_j)} \quad (\text{D.19})$$

where  $u_{k,\max}$  and  $u_{l,\max}$  are the peak ground displacements at supports  $k$  and  $l$  consistent with the respective local elastic response spectrum as given in EN 1998-1:2004, **3.2.2.4**;  $D_k(\omega_i, \xi_i)$  and  $D_l(\omega_j, \xi_j)$  are the elastic displacement response spectra values at supports  $k$  and  $l$  for frequencies and damping ratios of the considered modes, consistent with the respective local elastic response spectrum as given in EN 1998-1:2004, **3.2.2.2**.

(3) The correlation coefficients  $\rho_{u_k u_l}$ , between peak ground displacements, and  $\rho_{s_{ki} s_{lj}}$ , between normalised modal responses, are given by:

$$\begin{aligned} \rho_{u_k u_l} &= \frac{1}{\sigma_{u_k} \sigma_{u_l}} \int_{-\infty}^{\infty} G_{u_k u_l}(\omega) d\omega \\ \rho_{s_{ki} s_{lj}} &= \frac{1}{\sigma_{s_{ki}} \sigma_{s_{lj}}} \int_{-\infty}^{\infty} H_i(\omega) H_j(-\omega) G_{\ddot{u}_k \ddot{u}_l}(\omega) d\omega \\ \sigma_{u_k}^2 &= \int_{-\infty}^{\infty} G_{u_k u_k}(\omega) d\omega \\ \sigma_{s_{ki}}^2 &= \int_{-\infty}^{\infty} |H_i(\omega)|^2 G_{\ddot{u}_k \ddot{u}_k}(\omega) d\omega \end{aligned} \quad (\text{D.20})$$

where  $G_{u_k u_l}(\omega)$  is the  $kl$ -term of the power spectral densities matrix of the ground displacement processes, related to the corresponding one for the acceleration processes by:  $\mathbf{G}_{\mathbf{u}\mathbf{u}}(\omega) = \frac{1}{\omega^4} \mathbf{G}_{\ddot{\mathbf{u}}\ddot{\mathbf{u}}}(\omega)$ ;  $H_i(\omega)$  is the frequency transfer function of the normalised modal displacement, given by:

$$H_i(\omega) = \frac{1}{\omega_i^2 - \omega^2 + i2\xi_i \omega_i \omega} \quad (\text{D.21})$$

(4) In order to evaluate the integrals in Expression (D.20) the power spectral densities should be related to the response spectra that represent the information supposed to be available to the user of the present approach. The following approximate expression, slightly adjusted from that proposed in [4], can be used to relate response and power spectrum at any station:

<sup>6</sup> In Expression (D.19) one contribution has been omitted, which accounts for the correlation between the  $U$ -terms and the  $S$ -terms, i.e.  $\rho_{u_k s_{lj}}$ . Numerical analyses show that this contribution is insignificant and can be disregarded.

$$G_{iii}(\omega) = \omega^2 \left( \frac{2\xi\omega}{\pi} + \frac{4}{\pi\tau} \right) \left[ \frac{D(\omega, \xi)}{2.5} \right]^2 \quad \omega \geq 0 \quad (D.22)$$

where  $\tau$  is the duration of the stationary part of the ground motion to be taken consistently with the seismic event underlying the establishment of  $a_g$ .

(5) In practical cases, when local soil conditions differ from one support to another, the effect of this difference tends to dominate over the other two phenomena generating loss of correlation. Numerical analyses show in addition that the consideration of the third term  $\gamma_{ij,3}(\omega)$  in the coherency function has small influence on the results so that it can be, in approximation, set to zero. Based on these considerations and taking into account the approximate character of the described response spectrum procedure, a significant simplification is to consider a diagonal matrix  $\mathbf{G}(\omega)$ , i.e. to consider the structure as subjected to a vector of independent ground motion processes, each one characterised by its own power spectral density function. Correspondingly, Expression (D.19) simplifies to:

$$\mu_{z_{\max}} = \sqrt{\sum_{k=1}^m \alpha_k^2 u_{k,\max}^2 + \sum_{k=1}^m \sum_{i=1}^n \sum_{j=1}^n b_{ki} b_{kj} \rho_{s_{ki}s_{kj}} D_k(\omega_i, \xi_i) D_k(\omega_j, \xi_j)} \quad (D.23)$$

## References

- [1] Luco, J. and Wong, H., 1986, "Response of a rigid foundation to a spatially random ground motion" *Earth. Eng. Struct. Dyn.*, 14: 891-908
- [2] Der Kiureghian, A., 1996, "A coherency model for spatially varying ground motions" *Earth. Eng. Struct. Dyn.*, 25: 99-111
- [3] Shinozuka, M., 1972, "Monte Carlo solution of structural dynamics" *Comp. Struct.*, 2: 855-874
- [4] Der Kiureghian, A. and Neuenhofer, A., 1992, "Response spectrum method for multi-support seismic excitations" *Earth Eng. Struct. Dyn.*, 21: 713-740

## ANNEX E (INFORMATIVE)

### PROBABLE MATERIAL PROPERTIES AND PLASTIC HINGE DEFORMATION CAPACITIES FOR NON-LINEAR ANALYSES

#### E.1 General

(1) This Annex provides guidance for the selection of the probable material properties and for the estimation of the deformation capacities of the plastic hinges. Both are intended for use exclusively for non-linear analyses in accordance with 4.2.4 and 4.2.5.

#### E.2 Probable material properties

##### E.2.1 Concrete

(1) Mean values  $f_{cm}$ ,  $E_{cm}$  in accordance with EN 1992-1-1: 2004, Table 3.1 should be used.

(2) For unconfined concrete the stress-strain relationship for non-linear analysis specified in EN 1992-1-1:2004, 3.1.5(1), should be used, with the values of strains  $\varepsilon_{cl}$  and  $\varepsilon_{cu1}$  as specified in Table 3.1 of the same standard.

(3) For confined concrete the following procedure may be used, as an alternative to EN 1992-1-1:2004, 3.1.9 (see Figure E.1):

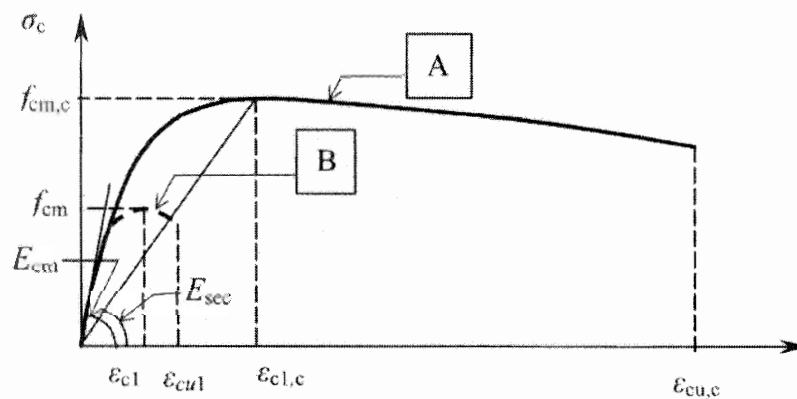

#### Key

A – Confined concrete  
B – Unconfined concrete

**Figure E.1: Stress-strain relationship for confined concrete**

NOTE This model of confined concrete properties is compatible with the values for  $\Phi_u$  and  $L_p$  given in expressions (E.18) and (E.19) respectively.

(a) Concrete stress  $\sigma_c$ :

$$\frac{\sigma_c}{f_{cm,c}} = \frac{xr}{r-1+x^r} \quad (E.1)$$

where:

$$x = \frac{\varepsilon_c}{\varepsilon_{cl,c}} \quad (E.2)$$

$$r = \frac{E_{cm}}{E_{cm} - E_{sec}} \quad (E.3)$$

secant modulus to ultimate strength:

$$E_{sec} = \frac{f_{cm,c}}{\varepsilon_{cl,c}} \quad (E.4)$$

ultimate strength:

$$f_{cm,c} = f_{cm} \lambda_c \quad (E.5)$$

$$\lambda_c = 2,254 \sqrt{1 + 7,94 \frac{\sigma_c}{f_{cm}} - \frac{2\sigma_c}{f_{cm}}} - 1,254 \quad (E.6)$$

strain at ultimate strength:

$$\varepsilon_{cl,c} = 0,002 \left[ 1 + 5 \left( \frac{f_{cm,c}}{f_{cm}} - 1 \right) \right] \quad (E.7)$$

(b) Effective confining stress  $\sigma_e$ :

$\sigma_e$  is the effective confining stress acting in both transverse directions 2 and 3 ( $\sigma_e = \sigma_{e2} = \sigma_{e3}$ ). This stress may be estimated on the basis of the ratio of confining reinforcement  $\rho_w$ , as defined in **6.2.1.2** or **6.2.1.3**, and its probable yield stress  $f_{ym}$  as follows:

– For circular hoops or spirals:

$$\sigma_e = \frac{1}{2} \alpha \rho_w f_{ym} \quad (E.8)$$

– For rectangular hoops or ties:

$$\sigma_e = \alpha \rho_w f_{ym} \quad (E.9)$$

where  $\alpha$  is the confinement effectiveness factor (see EN 1998-1: 2004, **5.4.3.2.2**)

For bridge piers confined in accordance with the detailing rules of 6.2.1 and with a minimum dimension  $b_{\min} \cong 1,0$  m, the value  $\alpha \cong 1,0$  may be assumed.

NOTE If, in the case of orthogonal hoops, the values of  $\rho_w$  in the two transverse directions are not equal ( $\rho_{w2} \neq \rho_{w3}$ ), the effective confining stress may be estimated as  $\sigma_c = \sqrt{\sigma_{c2}\sigma_{c3}}$ .

(c) Ultimate concrete strain  $\varepsilon_{cu,c}$

This strain should correspond to the first fracture of confining hoop reinforcement. Unless otherwise substantiated, it may be assumed as follows:

$$\varepsilon_{cu,c} = 0,004 + \frac{1,4\rho_s f_{ym} \varepsilon_{su}}{f_{cm,c}} \quad (\text{E.10})$$

where:

$\rho_s = \rho_w$  for circular spirals or hoops

$\rho_s = 2\rho_w$  for orthogonal hoops, and

$\varepsilon_{su} = \varepsilon_{um}$  is the mean value of the reinforcement steel elongation at maximum force (see EN 1992-1-1:2004, 3.2.2.2)

### E.2.2 Reinforcement steel

(1) In the absence of relevant information on the specific steel for the project, the following values may be used:

$$\frac{f_{ym}}{f_{yk}} = 1,15 \quad (\text{E.11})$$

$$\frac{f_{um}}{f_{tk}} = 1,20 \quad (\text{E.12})$$

$$\varepsilon_{su} = \varepsilon_{uk} \quad (\text{E.13})$$

### E.2.3 Structural steel

(1) In the absence of relevant information on the specific steel for the project, the following values may be used:

$$\frac{f_{ym}}{f_{yn}} = 1,25 \quad (\text{E.14})$$

$$\frac{f_{um}}{f_{un}} = 1,30 \quad (\text{E.15})$$

where  $f_{yn}$  and  $f_{un}$  are the nominal values of the yield and ultimate tensile strength respectively.

### E.3 Rotation capacity of plastic hinges

#### E.3.1 General

(1) In general the rotation capacity of plastic hinges,  $\theta_{p,u}$  (see **4.2.4.4(2)c**) should be evaluated on the basis of laboratory tests, satisfying the conditions of **2.3.5.2(3)**, that have been carried out on similar components. This applies for the deformation capacities of tensile members or of plastic shear mechanisms used in eccentric structural steel bracings.

(2) The similarity mentioned above refers to the following aspects of the components where relevant:

- geometry of the component
- loading rate
- ratios between action effects (bending moment, axial force, shear)
- reinforcement configuration (longitudinal and transverse reinforcement, including confinement), for reinforced concrete components
- local and/or shear buckling conditions for steel components

(3) In the absence of specific justification based on actual data, the reduction factor  $\gamma_{R,p}$  of expression (4.21) may be assumed as  $\gamma_{R,p} = 1,40$ .

#### E.3.2 Reinforced concrete

(1) In the absence of appropriate laboratory test results, as mentioned in **E.3.1**, the plastic rotation capacity  $\theta_{p,u}$ , and the total chord rotation  $\theta_u$  of plastic hinges (see Figure 2.4) may be estimated on the basis of the ultimate curvature  $\Phi_u$  and the plastic hinge length  $L_p$  (see Figure E.2), as follows:

$$\theta_u = \theta_y + \theta_{p,u} \quad (\text{E.16a})$$

$$\theta_{p,u} = (\Phi_u - \Phi_y)L_p \left(1 - \frac{L_p}{2L}\right) \quad (\text{E.16b})$$

where:

$L$  is the distance from the end section of the plastic hinge to the point of zero moment in the pier

$\Phi_y$  is the yield curvature

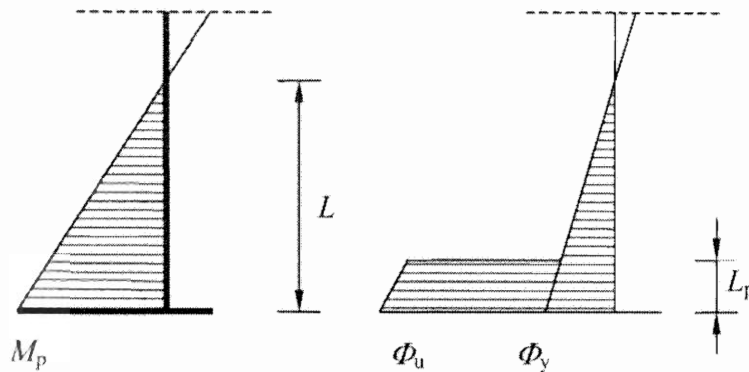
Figure E.2:  $\Phi_y$  and  $\Phi_u$ 

For linear variation of the bending moment, the yield rotation  $\theta_y$  may be assumed as:

$$\theta_y = \frac{\Phi_y L}{3} \quad (\text{E.17})$$

(2) Both  $\Phi_y$  and  $\Phi_u$  should be determined by means of a moment curvature analysis of the section under the axial load corresponding to the design seismic combination (see also (4)). When  $\varepsilon_c \geq \varepsilon_{cu1}$ , only the confined concrete core section should be taken into an account.

(3)  $\Phi_y$  should be evaluated by idealising the actual M- $\Phi$  diagram by a bilinear diagram of equal area beyond the first yield of reinforcement, as shown in Figure E.3.

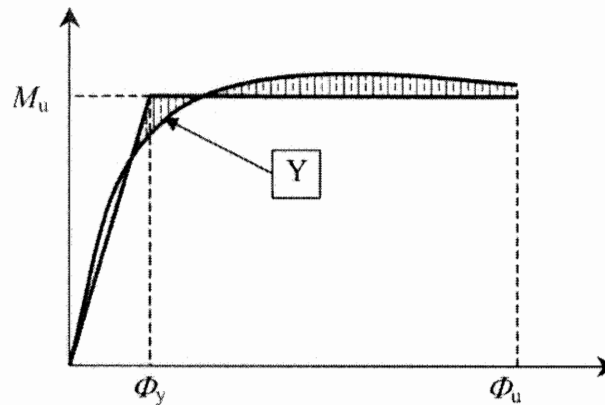

### Key

Y – Yield of first bar

Figure E.3: Definition of  $\Phi_y$ 

(4) The ultimate curvature  $\Phi_u$  at the plastic hinge of the member should be taken as:

$$\Phi_u = \frac{\varepsilon_s - \varepsilon_c}{d} \quad (\text{E.18})$$

where

$d$  is the effective section depth

$\varepsilon_s$  and  $\varepsilon_c$  are the reinforcement and concrete strains respectively (compressive strains negative), derived from the condition that either of the two or both have reached the following ultimate values:

- $\varepsilon_{cu1}$  for the compression strain of unconfined concrete (see EN 1992-1-1:2004, Table 3.1)
- $\varepsilon_{cu,c}$  for the compression strain of confined concrete (see **E.2.1(3)(c)** or EN 1992-1-1: 2004, **3.1.9(2)**)
- $\varepsilon_{su}$  for the tensile strain of reinforcement (see **E.2.1(3)(c)**)

(5) For a plastic hinge occurring at the top or the bottom junction of a pier with the deck or the foundation body (footing or pile cap), with longitudinal reinforcement of characteristic yield stress  $f_{yk}$  (in MPa) and bar diameter  $d_{bL}$ , the plastic hinge length  $L_p$  may be assumed as follows:

$$L_p = 0,10L + 0,015f_{yk}d_{bL} \quad (\text{E.19})$$

where  $L$  is the distance from the plastic hinge section to the section of zero moment, under the seismic action.

(6) The above estimation of the plastic rotation capacity is valid for piers with shear span ratio

$$\alpha_s = \frac{L}{d} \geq 3,0 \quad (\text{E.20})$$

For  $1,0 \leq \alpha_s < 3,0$  the plastic rotation capacity should be multiplied by the reduction factor

$$\lambda(\alpha_s) = \sqrt{\frac{\alpha_s}{3}} \quad (\text{E.21})$$



**ANNEX F (INFORMATIVE)**  
**ADDED MASS OF ENTRAINED WATER FOR IMMERSED PIERS**

(1) Unless otherwise substantiated by calculation, the total effective mass in a horizontal direction of an immersed pier should be assumed equal to the sum of:

- the actual mass of the pier (without allowance for buoyancy);
- the mass of water possibly enclosed within the pier (for hollow piers);
- the added mass  $m_a$  of externally entrained water per unit length of immersed pier.

(2) For piers of circular cross-section of radius  $R$ ,  $m_a$  may be estimated as:

$$m_a = \rho\pi R^2 \quad (F.1)$$

where  $\rho$  is the water density.

(3) For piers of elliptical section (see Figure F1) with axes  $2a_x$  and  $2a_y$  and horizontal seismic action at an angle  $\theta$  to the x-axis of the section,  $m_a$  may be estimated as:

$$m_a = \rho\pi (a_y^2 \cos^2\theta + a_x^2 \sin^2\theta) \quad (F.2)$$

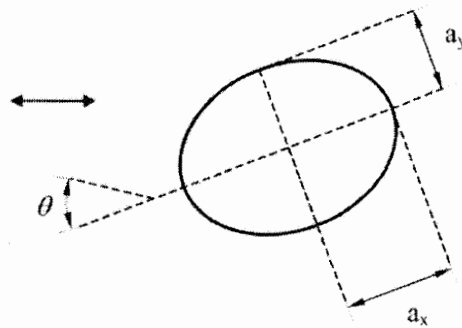

**Figure F.1: Definition of dimensions of elliptical pier section**

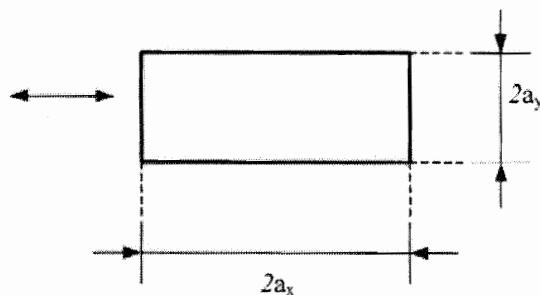

**Figure F.2: Definition of dimensions of rectangular pier section**

(4) For piers of rectangular section with dimensions  $2a_x$  by  $2a_y$  and for earthquake action in the x-direction (see Figure F.2),  $m_a$  may be estimated as:

$$m_a = k\rho\pi a_y^2 \quad (\text{F.3})$$

where the value of  $k$  is taken from Table F.1 (linear interpolation is permitted).

**Table F.1 Dependence of added mass coefficient of rectangular piers on cross-sectional aspect ratio**

$a_y/a_x$	$k$
0,1	2,23
0,2	1,98
0,5	1,70
1,0	1,51
2,0	1,36
5,0	1,21
10,0	1,14
$\infty$	1,00

## ANNEX G (NORMATIVE) CALCULATION OF CAPACITY DESIGN EFFECTS

### G.1 General procedure

(1)P The following procedure shall be applied in general, separately for each of the two horizontal components of the design seismic action with signs + or –:

(2)P Step 1:

Calculation of the design flexural strengths  $M_{Rd,h}$  of the sections of the intended plastic hinges, corresponding to the selected horizontal direction of the seismic action ( $A_E$ ) with the sign considered (+ or –). The strengths shall be based on the actual dimensions of the cross-sections and the final amount of longitudinal reinforcement. The calculation shall consider the interaction with the axial force and possibly with the bending moment in the orthogonal direction, both resulting from the analysis in the design seismic situation of expression (5.4) of 5.5.

(3)P Step 2:

Calculation of the change of action effects  $\Delta A_C$  of the plastic mechanism, corresponding to the increase of the moments of the plastic hinges ( $\Delta M_h$ ), from (a) the values due to the permanent actions ( $M_{G,h}$ ) to (b) the overstrength moments of the sections.

$$\Delta M_h = \gamma_o M_{Rd,h} - M_{G,h} \quad (G.1)$$

where  $\gamma_o$  is the overstrength factor specified in 5.3.

(4) The effects  $\Delta A_C$  may in general be estimated from equilibrium conditions, while reasonable approximations regarding the compatibility of deformations are acceptable.

(5)P Step 3:

The final capacity design effects  $A_C$  shall be obtained by superimposing the change  $\Delta A_C$  to the permanent action effects  $A_G$

$$A_C = A_G + \Delta A_C \quad (G.2)$$

### G.2 Simplifications

(1) Simplifications of the general procedure specified in G.1 are allowed, as long as G.1(4) is satisfied.

(2) When the bending moment due to the permanent actions at the plastic hinge is negligible compared to the moment overstrength of the section ( $M_{G,h} \ll \gamma_o M_{Rd,h}$ ), Step 2 in G.1(3)P may be replaced by a direct estimation of the effects  $\Delta A_C$  from the effects  $A_E$  of the design seismic action. This is usually the case in the transverse direction of the piers, or in both directions when the piers are hinged to the deck. In such cases the capacity design shear of pier "i" may be estimated as follows:

$$V_{C,i} = \Delta V_i = \frac{\gamma_o M_{Rd,h,l}}{M_{E,i}} V_{E,i} \quad (G.3)$$

and the capacity design effects on the deck and on the abutments may be estimated from the relationship:

$$\Delta A_C \cong \frac{\Sigma V_{C,i}}{\Sigma V_{E,i}} A_E \quad (G.4)$$

## ANNEX H (INFORMATIVE) STATIC NON-LINEAR ANALYSIS (PUSHOVER)

### H.1 Analysis directions, reference point and target displacements

(1) The non-linear static analysis specified in **4.2.5** should be carried out in the following two horizontal directions:

- the longitudinal direction  $x$ , as defined by the centres of the two end-sections of the deck.
- the transverse direction  $y$ , that should be assumed to be orthogonal to the longitudinal direction.

(2) The reference point should be the centre of mass of the deformed deck.

(3) In each of the two horizontal directions  $x$  and  $y$ , defined in **(1)** above, a static non-linear analysis in accordance with **4.2.5** should be carried out, until the following target displacements of the reference point are reached:

- in  $x$ -direction (longitudinal):

$$d_{T,x} = d_{E,x} \quad (\text{H.1})$$

- in  $y$ -direction: (transverse) :

$$d_{T,y} = d_{E,y} \quad (\text{H.2})$$

where:

$d_{E,x}$  is the displacement in the  $x$ -direction, at the centre of mass of the deformed deck, resulting from equivalent linear multi-mode spectrum analysis (in accordance with **4.2.1.3**) assuming  $q = 1,0$  due to  $E_x$  “+”  $0,3E_y$ . The spectrum analysis should be carried out using effective stiffness of ductile members as specified in **2.3.6.1**.

$d_{E,y}$  is the displacement in  $y$ -direction at the same point calculated similarly to  $d_{E,x}$  above.

### H.2 Load distribution

(1) The horizontal load increments  $\Delta F_{i,j}$  assumed acting on lumped mass  $M_i$ , in the direction investigated, at each loading step  $j$ , should be taken as equal to:

$$\Delta F_{i,j} = \Delta \alpha_j g M_i \zeta_i \quad (\text{H.3})$$

where:

$\Delta \alpha_j$  is the horizontal force increment, normalized to the weight  $gM_i$ , applied in step  $j$ , and

$\zeta_i$  is a shape factor defining the load distribution along the structure.

(2) Unless a better approximation is used, both of the following distributions should be investigated:

a) *constant along the deck*, where

for the deck

$$\zeta_i = 1 \quad (\text{H.4})$$

and for the piers connected to the deck

$$\zeta_i = \frac{z_i}{z_p} \quad (\text{H.5})$$

where

$z_i$  is the height of point  $i$  above the foundation of the individual pier and

$z_p$  is the total height of pier  $P$  (distance from the ground to the centre line of the deck).

b) *proportional to the first mode shape*, where

$\zeta_i$  is proportional to the component, in the considered horizontal direction, of the modal displacement at point  $i$ , of the first mode, in the same direction. The mode with the largest participation factor in the considered direction, should be taken as first mode in this direction. Especially for the piers, the following approximation may be used alternatively

$$\zeta_i = \zeta_{T,P} \frac{z_i}{z_p} \quad (\text{H.6})$$

where  $\zeta_{T,P}$  is the value of  $\zeta$  corresponding to the joint connecting the deck and pier  $P$ .

### H.3 Deformation demands

(1) Deformation demands at each plastic hinge should be verified using expression (4.20) where  $\theta_{Ed}$  denotes the maximum chord rotation demands, when the target displacement is reached (see 4.2.4.4(2)c).

(2) In each direction, the total deformation at the first loading step when the two sides of expression (4.20) become equal at any plastic hinge, defines the design ultimate deformation state of the bridge. If, at this state, the displacement of the reference point is less than the target displacement in the relevant direction, the design should be considered unsatisfactory and should be modified.

NOTE 1: Increasing the longitudinal reinforcement of the critical plastic hinge sections, within the limits of constructability, leads primarily to a corresponding increase of the effective stiffness of the ductile members (in accordance with 2.3.6.1) and consequently to a reduction of the target displacement in accordance with H.1(3), and of the deformation demands  $\theta_{Ed}$  of H.3(1). In general increasing the dimensions of the sections of the ductile members leads to a reduction of the deformation demands, as well as to an increase in the deformation capacities of the members.

NOTE 2: A design procedure of the ductile members along these lines involves only deformation/displacement verifications (no strength verifications). However, non-ductile failure verifications (shear) of both the ductile and non-ductile members are carried out through strength verifications, in accordance with **4.2.4.4(2)(e)**.

(3) In the longitudinal direction of an essentially straight bridge, the displacements of all pier heads connected to the deck are practically equal to the displacement of the reference point. In this case the deformation demands of the plastic hinges can be assessed directly from the target displacement.

#### **H.4 Deck verification**

(1) It should be verified that no significant yielding, in accordance with **5.6.3.6(2)** and **5.6.3.6(3)**, occurs in the deck before the target displacement is reached (see **4.2.4.4(2)d**).

(2) Up-lift of all bearings at the same support, before the target displacement is reached, should be avoided. Up-lift of individual bearings of the same support, before the target displacement is reached, is acceptable, if it has no detrimental effect on the bearings.

#### **H.5 Verification of non-ductile failure modes and of the foundation soil**

(1) All members should be verified against non-ductile failure modes (shear), in accordance with **4.2.4.4(2)e**, using the force distribution corresponding to the target displacement as design actions. The same applies for the verification of the foundation soil.

## ANNEX J (NORMATIVE)

### VARIATION OF DESIGN PROPERTIES OF SEISMIC ISOLATOR UNITS

#### J.1 Factors causing variation of design properties

(1) The assessment of Upper Bound Design Properties and Lower Bound Design Properties (UBDPs and LBDPs) required for the design of the isolating system in accordance with 7.5.2.4, should be established by evaluating the influence of the following factors on each property:

- $f_1$ : ageing (including corrosion);
- $f_2$ : temperature (minimum isolator design temperature  $T_{\min,b}$ );
- $f_3$ : contamination;
- $f_4$ : cumulative travel (wear).

In general the design properties of cyclic response influenced by the above factors are the following (see Figure 7.1 and Figure 7.3).

- The post elastic stiffness  $K_p$ .
- The force at zero displacement  $F_0$ .

<sup>A2</sup>(2) The minimum isolator temperature for the seismic design situation,  $T_{\min,b}$ , should correspond to the climatic conditions of the bridge location.

NOTE The method for determining the value of the minimum isolator temperature for use in a country in the seismic design situation may be found in its National Annex. The recommended method is as follows:

$$T_{\min,b} = T_{av} - \psi_2 (T_{av} - T_{\min}) + \psi_2 \Delta T_1$$

where

$T_{av}$  is the annual average shade air temperature at the location of the bridge. It may be taken as the average of the characteristic values of the maximum and minimum ambient shade air temperatures at ' bridge location, in accordance with EN 1991-1-5:2003, 6.1.3.2 i.e.  $T_{av} = (T_{\max} + T_{\min})/2$ . If no specific information is available the value  $T_{av} = 10^\circ\text{C}$  may be used.

$\psi_2$  is the combination factor for thermal actions for seismic design situations, in accordance with EN 1990:2002 and EN 1990:2002/A1:2005, Annex A2 and

$\Delta T_1 = T_{e,\min} - T_{\min}$  is the difference between the minimum uniform bridge temperature component  $T_{e,\min}$  and the minimum shade air temperature  $T_{\min}$ , in accordance with EN 1991-1-5: 2003 and EN 1991-1-5:2003/AC:2009, 6.1.3.1(4). <sup>A2</sup>

#### J.2 Evaluation of the variation

(1) In general the effect of each of the factors  $f_i$  ( $i = 1$  to 4) listed in J.1 on each design property, should be evaluated by comparing: (a) the maximum and minimum values ( $maxDP_{f_i}$  and  $minDP_{f_i}$ ) of the design property, resulting from the influence of factor  $f_i$ , to (b) the maximum and minimum nominal values ( $maxDP_{nom}$  and  $minDP_{nom}$ ) respectively, of the same property, as measured by Prototype tests. The following ratios should be established for the influence of each factor  $f_i$  on the investigated design property.



$$\lambda_{\max,fi} = \frac{\max DP_{fi}}{\max DP_{\text{nom}}} \quad (\text{J.2})$$

$$\lambda_{\min,fi} = \frac{\min DP_{fi}}{\min DP_{\text{nom}}} \quad (\text{J.3})$$

NOTE 1: Informative Annex K provides guidance on prototype (or type) tests in cases where prEN 15129:200X (“Anti-seismic devices”) does not include detailed requirements for such tests

NOTE 2: The values to be ascribed to the  $\lambda$ -factors for use in a country may be found in its National Annex. Recommended values/guidance for commonly used isolators, i.e. special elastomeric bearings, lead-rubber bearings, sliding isolating units and hydraulic viscous dampers, is given in Informative Annex JJ.

(2) The effective UBDP used in the design should be estimated as follows:

$$UBDP = \max DP_{\text{nom}} \cdot \lambda_{U,f1} \cdot \lambda_{U,f2} \dots \lambda_{U,fi5} \quad (\text{J.4})$$

with modification factors

$$\lambda_{U,fi} = 1 + (\lambda_{\max,fi} - 1) \psi_{fi} \quad (\text{J.5})$$

where, the combination factors  $\psi_{fi}$  account for the reduced probability of simultaneous occurrence of the maximum adverse effects of all factors and should be assumed in accordance with Table J.2:

**Table J.2: Combination factors  $\psi_{fi}$**

Importance Class	$\psi_{fi}$
III	0,90
II	0,70
I	0,60

(3) In general, for the effective LBDP (and relevant modification factors  $\lambda_{L,fi}$ ) a similar format as that of expressions (J.4) and (J.5) should be used, in conjunction with  $\lambda_{\min,fi}$ . However for the commonly used elastomeric and friction bearings, it may be assumed in general that:

$$\lambda_{\min,fi} = 1 \quad (\text{J.6})$$

and therefore

$$LBDP = \min DP_{\text{nom}} \quad (\text{J.7})$$

(4) For hydraulic dampers and in the absence of specific tests, it may be assumed that:

$$UBDP = \max DP_{\text{nom}}$$

$$LBDP = \min DP_{\text{nom}}$$

**ANNEX JJ (INFORMATIVE)**  
 **$\lambda$ -FACTORS FOR COMMON ISOLATOR TYPES**

**JJ.1  $\lambda_{\max}$ -values for elastomeric bearings**

(1) Unless different values are substantiated by appropriate tests, the  $\lambda_{\max}$ -values specified in following Tables JJ.1 to JJ.4 may be used for estimation of the UBDP.

**Table JJ.1:  $f_1$  - Ageing**

Component	$\lambda_{\max, f1}$ for	
	$K_p$	$F_o$
LDRB	1,1	1,1
HDRB1	1,2	1,2
HDRB2	1,3	1,3
Lead core	-	1,0

with the following designation for the rubber components:

LDRB: Low damping rubber bearing with shear modulus, at shear deformation of 100%, larger than 0,5 MPa

HDRB1: High damping rubber bearing with  $\zeta_{\text{eff}} \leq 0,15$  and shear modulus, at shear deformation of 100%, larger than 0,5 MPa

HDRB2: High damping rubber bearing with  $\zeta_{\text{eff}} > 0,15$  or shear modulus, at shear deformation of 100%, smaller or equal to 0,5 MPa

Lead core: Lead core for Lead rubber bearings (LRB)

**Table JJ.2:  $f_2$  - Temperature**

Design Temperature $T_{\min, b}$ (°C)	$\lambda_{\max, f2}$ for					
	$K_p$			$F_o$		
	LDRB	HDRB1	HDRB2	LDRB	HDRB1	HDRB2
20	1,0	1,0	1,0	1,0	1,0	1,0
0	1,1	1,1	1,2	1,3	1,3	1,3
-10	1,1	1,2	1,4	1,4	1,4	1,4
-30	1,3	1,4	2,0	1,5	2,0	2,5

$T_{\min, b}$  is the minimum isolator temperature for the seismic design situation, corresponding to the bridge location (see (2) of J.1 of Annex J).<sup>(A)</sup>

**Table JJ.3:  $f_3$  - Contamination**

$\lambda_{\max, f3} = 1,0$
----------------------------

**Table JJ.4:  $f_4$  - Cumulative travel**

Rubber	$\lambda_{\max, f4} = 1,0$
Lead core	To be established by test

**JJ.2  $\lambda_{\max}$ -values for sliding isolator units**

(1) Unless different values are substantiated by appropriate test results, the  $\lambda_{\max}$ -values specified in the following Tables JJ.5 to JJ.8 may be used for the estimation of the maximum force at zero displacement  $F_0$  corresponding to the UBDP. The values given for unlubricated PTFE may be taken to apply also for Friction Pendulum bearings.

**Table JJ.5:  $f_1$  - Ageing**

Component	$\lambda_{\max,f1}$					
	Unlubricated PTFE		Lubricated PTFE		Bimetallic Interfaces	
Environment	Sealed	Unsealed	Sealed	Unsealed	Sealed	Unsealed
Normal	1,1	1,2	1,3	1,4	2,0	2,2
Severe	1,2	1,5	1,4	1,8	2,2	2,5

The values in Table JJ.5 refer to the following conditions:

- Stainless steel sliding plates are assumed
- Unsealed conditions are assumed, to allow exposure of the sliding surfaces to water and salt
- Severe environment includes marine and industrial conditions

Values for bimetallic interfaces apply to stainless steel and bronze interface.

**Table JJ.6:  $f_2$  - Temperature**

Design Temperature	$\lambda_{\max,f2}$		
$T_{\min,b}$ (° C)	Unlubricated PTFE	Lubricated PTFE	Bimetallic Interfaces
20	1,0	1,0	To be established by test
0	1,1	1,3	
-10	1,2	1,5	
-30	1,5	3,0	

**Table JJ.7:  $f_3$  - Contamination**

Installation	$\lambda_{\max,f3}$		
	Unlubricated PTFE	Lubricated PTFE	Bimetallic Interfaces
Sealed, with stainless steel surface facing down	1,0	1,0	1,0
Sealed, with stainless steel surface facing up	1,1	1,1	1,1
Unsealed, with stainless steel surface facing down	1,2	3,0	1,1

The values in Table JJ.7 refer to the following conditions:

- Sealing of bearings is assumed to offer contamination protection under all serviceability conditions

**Table JJ.8:  $f_4$  – Cumulative travel**

Cumulative Travel (km)	$\lambda_{\max, f4}$		
	Unlubricated PTFE	Lubricated PTFE	Bimetallic Interfaces
$\leq 1,0$	1,0	1,0	To be established by test
$1,0 < \text{and } \leq 2$	1,2	1,0	To be established by test

## ANNEX K (INFORMATIVE) TESTS FOR VALIDATION OF DESIGN PROPERTIES OF SEISMIC ISOLATOR UNITS

### K.1 Scope

- (1) This Informative Annex is intended to provide guidance on prototype (or type) testing in cases where prEN 15129:200X (“Anti-seismic devices”) does not include detailed requirements for such testing.
- (2) The range of values of the deformation characteristics and damping values of the isolator units used in the design and analysis of seismic-isolated bridges may be validated by the tests described in this Annex. These tests are not intended for use as quality control tests.
- (3) The prototype tests specified in **K.2** aim to establish or validate the range of nominal design properties of the isolator units assumed in the design. These tests in general may be project specific. However, available results of tests performed on specimens of similar type and size and with similar values of design parameters are acceptable.
- (4) The purpose of the tests of **K.3** is to substantiate properties of the isolators, which are usually not project specific.

### K.2 Prototype tests

#### K.2.1 General

- (1) The tests should be performed on a minimum of two specimens. Specimens should not be subjected to any lateral or vertical loading prior to prototype testing.
- (2) In general, full size specimens should be used. The competent authority may allow performance of certain tests on reduced scale specimens, only when existing testing facilities do not have the capacity required for testing full-size specimens.
- (3) When reduced scale specimens are used, they should be of the same material and type, geometrically similar to the full-size specimens, and should be manufactured with the same process and quality control.

#### K.2.2 Sequence of tests

- (1) The following sequence of tests should be performed for the prescribed number of cycles, at a vertical load equal to the average permanent load, on all isolator units of a common type and size.

$T_1$  Three fully reversed cycles at plus and minus the maximum thermal displacement at a test velocity not less than 0,1 mm/min.

- $T_2$  Twenty fully reversed cycles of loading at plus and minus the maximum non-seismic design reaction, at an average test frequency of 0,5 Hz. Following the cyclic testing, the load should be held on the specimen for 1 minute.
- $T_3$  Five fully reversed cycles at the increased design seismic displacement.
- $T_4$  Fifteen fully reversed cycles at the increased design displacement, starting at the offset displacement (7.6.2(2)P). The cycles may be applied in three groups of five cycles each, with each group separated by idle time to allow for specimen cooling down.
- $T_5$  Repetition of test  $T_2$  but with the number of cycles reduced to three.
- $T_6$  If an isolator unit is also a vertical load-carrying element, then it should also be tested for one fully reversed cycle at the total design seismic displacement under the following vertical loads:

$$1,2 Q_G + |\Delta F_{Ed}|$$

$$0,8 Q_G - |\Delta F_{Ed}|$$

where

$Q_G$  is the permanent load and

$\Delta F_{Ed}$  is the additional vertical load due to seismic overturning effects, based on peak response under the design seismic action.

(2) Tests  $T_3$ ,  $T_4$  and  $T_6$  should be performed at a frequency equal to the inverse of the effective period of the isolating system. Exception from this rule is permitted for isolator units that are not dependent on the rate of loading (the rate of loading has as primary effect the viscous or frictional heating of the specimen). The force displacement characteristics of an isolator unit are considered to be independent of the rate of loading, when there is less than 15% difference on either of the values of  $F_o$  and  $K_p$  defining the hysteresis loop (see Figure 7.1), when tested for three fully reversed cycles at the design displacement and frequencies in the range of 0,2 to 2 times the inverse of the effective period of the isolating system.

### K.2.3 Determination of isolators characteristics

#### K.2.3.1 Force-displacement characteristics

(1) The effective stiffness of an isolator unit should be calculated for each cycle of loading as follows:

$$K_{\text{eff}} = \frac{F_p - F_n}{d_p - d_n} \quad (\text{K.1})$$

where:

$d_p$  and  $d_n$  are the maximum positive and maximum negative test displacement, respectively, and

$F_p$  and  $F_n$  are the maximum positive and negative forces, respectively, for units with hysteretic and frictional behaviour, or the positive and negative forces corresponding to  $d_p$  and  $d_n$ , respectively, for units with viscoelastic behaviour.

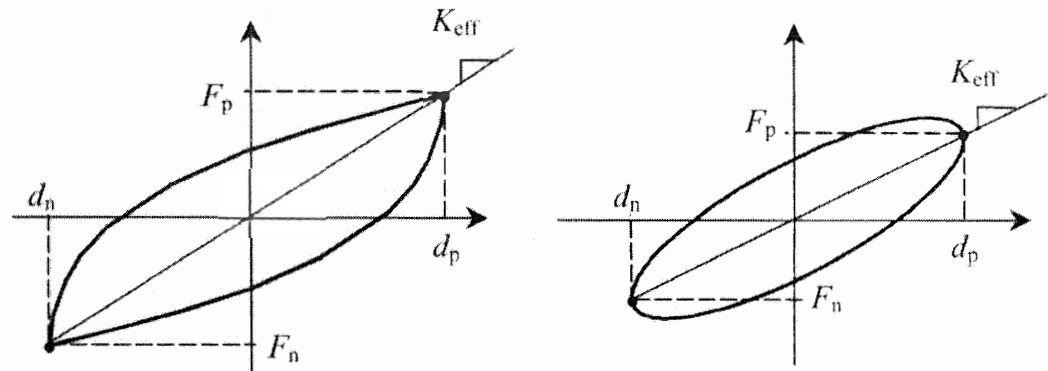

**Figure K1: Force-displacement diagrams of tests (Left: hysteretic or friction behaviour; right: viscous behaviour)**

### K.2.3.2 Damping characteristics

(1) The energy dissipated per cycle  $E_{Di}$  of an isolator unit  $i$ , should be determined for each cycle of loading as the area of the relevant hysteresis loop of the five fully reversed cycles at the total design displacement of test  $T_3$  of K.2.2.

### K.2.3.3 System adequacy

(1) The performance of the test specimens should be considered as adequate if the following requirements are satisfied:

- $R_1$  except for fluid viscous dampers, the force-displacement plots of all tests specified in K.2.2 should have a positive incremental force-carrying capacity.
- $R_2$  in test  $T_1$  of K.2.2 the maximum measured force should not exceed the design value by more than 5%.
- $\text{A1}$   $R_3$  in tests  $T_2$  and  $T_5$  of K.2.2 the maximum measured displacement should not exceed 110% of the design value.  $\text{A1}$
- $R_4$  in test  $T_3$  of K.2.2, the maximum and minimum values of the effective stiffness  $K_{\text{eff}}$  of isolator unit  $i$  (and the corresponding force-displacement diagrams), as well as of the energy dissipated per cycle,  $E_{Di}$ , should be determined as the maximum and minimum, respectively, of the average of each of the four pairs of consecutive cycles of the test. These nominal properties should be within the range of nominal properties, assumed by the design.
- $R_5$  In test  $T_4$  of K.2.2, the ratio of the minimum to the maximum effective stiffness measured in each of the 15 cycles should be not less than 0,7.
- $R_6$  In test  $T_4$  of K.2.2, the ratio  $\min E_D / \max E_D$  for each of the 15 cycles should not be less than 0,7.

*R*<sub>7</sub> All vertical load-carrying units should remain stable (i.e. with positive incremental stiffness) during the test *T*<sub>6</sub> of **K.2.2**.

*R*<sub>8</sub> Following the conclusion of the tests, all test specimens should be inspected for evidence of significant deterioration, which may constitute cause for rejection, such as (where relevant):

- Lack of rubber to steel bond
- Laminate placement fault
- Surface rubber cracks wider or deeper than 70% of rubber cover thickness
- Material peeling over more than 5% of the bonded area
- Lack of PTFE to metal bond over more than 5% of the bonded area
- Scoring of stainless steel plate by marks deeper or wider than 0,5 mm and over a length exceeding 20 mm
- Permanent deformation
- Leakage

### **K.3 Other tests**

#### **K.3.1 Wear and fatigue tests**

(1) These tests should account for the influence of cumulative travel due to displacements caused by thermal and traffic loadings, over a service life to at least 30 years.

(2) For bridges of normal length (up to about 200 m) and unless a different value is substantiated by calculation, the minimum cumulative travel may be taken as 2000 m.

#### **K.3.2 Low temperature tests**

(1) If the isolator units are intended to be used in low temperature areas, with minimum isolator temperature for seismic design  $T_{\min,b} < 0^{\circ}\text{C}$  (see **J.1(2)**), then a test should be performed at this temperature, consisting of five fully reversed cycles at the design displacement, with the remaining conditions as specified in test *T*<sub>3</sub> of **K.2.2**. The specimen should be kept below freezing for at least two days before the test. The results should be evaluated as specified in *R*<sub>4</sub> of **K.2.3.3(1)**.

(2) In the tests of **K.3.1**, 10% of the travel should be performed under temperature  $T_{\min,b}$ .



