

The European Union

EDICT OF GOVERNMENT

In order to promote public education and public safety, equal justice for all, a better informed citizenry, the rule of law, world trade and world peace, this legal document is hereby made available on a noncommercial basis, as it is the right of all humans to know and speak the laws that govern them.

EN 1999-1-3 (2007) (English): Eurocode 9: Design of aluminium structures - Part 1-3: Structures susceptible to fatigue [Authority: The European Union Per Regulation 305/2011, Directive 98/34/EC, Directive 2004/18/EC]



BLANK PAGE



ICS 91.010.30; 91.080.10

English Version

Eurocode 9: Design of aluminium structures - Part 1-3: Structures susceptible to fatigue

Eurocode 9: Calcul des structures en aluminium - Partie 1-3: Structures sensibles à la fatigue

Eurocode 9: Bemessung und Konstruktion von Aluminiumtragwerken - Teil 1-3: Ermüdungsbeanspruchte Tragwerke

This amendment A1 modifies the European Standard EN 1999-1-3:2007; it was approved by CEN on 26 May 2011.

CEN members are bound to comply with the CEN/CENELEC Internal Regulations which stipulate the conditions for inclusion of this amendment into the relevant national standard without any alteration. Up-to-date lists and bibliographical references concerning such national standards may be obtained on application to the CEN-CENELEC Management Centre or to any CEN member.

This amendment exists in three official versions (English, French, German). A version in any other language made by translation under the responsibility of a CEN member into its own language and notified to the CEN-CENELEC Management Centre has the same status as the official versions.

CEN members are the national standards bodies of Austria, Belgium, Bulgaria, Croatia, Cyprus, Czech Republic, Denmark, Estonia, Finland, France, Germany, Greece, Hungary, Iceland, Ireland, Italy, Latvia, Lithuania, Luxembourg, Malta, Netherlands, Norway, Poland, Portugal, Romania, Slovakia, Slovenia, Spain, Sweden, Switzerland and United Kingdom.



EUROPEAN COMMITTEE FOR STANDARDIZATION
COMITÉ EUROPÉEN DE NORMALISATION
EUROPÄISCHES KOMITEE FÜR NORMUNG

Management Centre: Avenue Marnix 17, B-1000 Brussels

Contents

Page

Foreword.....	5
1 General.....	9
1.1 Scope	9
1.1.1 Scope of EN 1999.....	9
1.1.2 Scope of EN 1999-1-3	9
1.2 Normative references	10
1.3 Assumptions	10
1.4 Distinction between principles and application rules.....	11
1.5 Terms and definitions	11
1.5.1 General.....	11
1.5.2 Additional terms used in EN 1999-1-3	11
1.6 Symbols	14
1.7 Specification for execution.....	16
1.7.1 Execution specification.....	16
1.7.2 Operation manual	16
1.7.3 Inspection and maintenance manual.....	16
2 Basis of design	17
2.1 General.....	17
2.1.1 Basic requirements.....	17
2.2 Procedures for fatigue design.....	17
2.2.1 Safe life design.....	17
2.2.2 Damage tolerant design	18
2.2.3 Design assisted by testing	19
2.3 Fatigue loading	19
2.3.1 Sources of fatigue loading.....	19
2.3.2 Derivation of fatigue loading	19
2.3.3 Equivalent fatigue loading	20
2.4 Partial factors for fatigue loads.....	20
2.5 Execution requirements.....	21
3 Materials, constituent products and connecting devices	21
4 Durability	21
5 Structural analysis.....	22
5.1 Global analysis.....	22
5.1.1 General.....	22
5.1.2 Use of beam elements.....	23
5.1.3 Use of membrane, shell and solid elements.....	23
5.2 Types of stresses.....	24
5.2.1 General.....	24
5.2.2 Nominal stresses	24
5.2.3 Modified nominal stresses.....	24
5.2.4 Hot spot stresses.....	25
5.3 Derivation of stresses	27
5.3.1 Derivation of nominal stresses	27
5.3.2 Derivation of modified nominal stresses	27
5.3.3 Derivation of hot spot stresses	28
5.3.4 Stress orientation	28
5.4 Stress ranges for specific initiation sites	28
5.4.1 Parent material, welds, and mechanically fastened joints	28
5.4.2 Fillet and partial penetration butt welds.....	28
5.5 Adhesive bonds	29
5.6 Castings.....	29

5.7	Stress spectra	29
5.8	Calculation of equivalent stress range for standardised fatigue load models	29
5.8.1	General	29
5.8.2	Design value of stress range	30
6	Fatigue resistance and detail categories	31
6.1	Detail categories	31
6.1.1	General	31
6.1.2	Factors affecting detail category	31
6.1.3	Constructional details	31
6.2	Fatigue strength data	32
6.2.1	Classified constructional details	32
6.2.2	Unclassified details	34
6.2.3	Adhesively bonded joints	34
6.2.4	Determination of the reference hot spot strength values	34
6.3	Effect of mean stress	34
6.3.1	General	34
6.3.2	Plain material and mechanically fastened joints	35
6.3.3	Welded joints	35
6.3.4	Adhesive joints	35
6.3.5	Low endurance range	35
6.3.6	Cycle counting for R-ratio calculations	35
6.4	Effect of exposure conditions	35
6.5	Improvement techniques	36
Annex A	[normative]: Basis for calculation of fatigue resistance	37
A.1	General	37
A.1.1	Influence of fatigue on design	37
A.1.2	Mechanism of failure	37
A.1.3	Potential sites for fatigue cracking	37
A.1.4	Conditions for fatigue susceptibility	38
A.2	Safe life design	38
A.2.1	Prerequisites for safe life design	38
A.2.2	Cycle counting	39
A.2.3	Derivation of stress spectrum	39
A.3	Damage tolerant design	42
A.3.1	Prerequisites for damage tolerant design	42
A.3.2	Determination of inspection strategy for damage tolerant design	42
Annex B	[informative]: Guidance on assessment of crack growth by fracture mechanics	45
B.1	Scope	45
B.2	Principles	45
B.2.1	Flaw dimensions	45
B.2.2	Crack growth relationship	46
B.3	Crack growth data A and m	46
B.4	Geometry function y	48
B.5	Integration of crack growth	48
B.6	Assessment of maximum crack size a_2	48
Annex C	[informative]: Testing for fatigue design	58
C.1	General	58
C.2	Derivation of action loading data	58
C.2.1	Fixed structures subject to mechanical action	58
C.2.2	Fixed structures subject to actions due to exposure conditions	59
C.2.3	Moving structures	59
C.3	Derivation of stress data	59
C.3.1	Component test data	59
C.3.2	Structure test data	60
C.3.3	Verification of stress history	60
C.4	Derivation of endurance data	60
C.4.1	Component testing	60
C.4.2	Full scale testing	61

C.4.3	Acceptance.....	61
C.5	Crack growth data.....	64
C.6	Reporting.....	64
Annex D	[informative]: Stress analysis.....	65
D.1	Use of finite elements for fatigue analysis.....	65
D.1.1	Element types.....	65
D.1.2	Further guidance on use of finite elements.....	66
D.2	Stress concentration factors.....	66
D.3	Limitation of fatigue induced by repeated local buckling.....	68
Annex E	[informative]: Adhesively bonded joints.....	69
Annex F	[informative]: Low cycle fatigue range.....	71
F.1	Introduction.....	71
F.2	Modification to $\Delta\sigma-N$ curves.....	71
F.3	Test data.....	71
Annex G	[informative]: Influence of R-ratio.....	73
G.1	Enhancement of fatigue strength.....	73
G.2	Enhancement cases.....	73
G.2.1	Case 1.....	73
G.2.2	Case 2.....	74
G.2.3	Case 3.....	74
Annex H	[informative]: Fatigue strength improvement of welds.....	75
H.1	General.....	75
H.2	Machining or grinding.....	75
H.3	Dressing by TIG or plasma.....	76
H.4	Peening.....	76
Annex I	[informative]: Castings.....	77
I.1	General.....	77
I.2	Fatigue strength data.....	77
I.2.1	Plain castings.....	77
I.2.2	Welded material.....	77
I.2.3	Mechanically joined castings.....	77
I.2.4	Adhesively bonded castings.....	78
I.3	Quality requirements.....	78
Annex J	[informative]: Detail category tables.....	79
J.1	General.....	79
Annex K	[informative]: Hot spot reference detail method.....	95
Annex L	[informative]: Guidance on use of design methods, selection of partial factors, limits for damage values, inspection intervals and execution parameters when Annex J is adopted.....	96
L.1	Safe life method.....	96
L.2	Damage tolerant design method.....	96
L.2.1	General.....	96
L.2.2	DTD-I.....	97
L.2.3	DTD-II.....	97
L.3	Start of inspection and inspection intervals.....	98
L.4	Partial factors γ_{Mf} and the values of D_{Lim}	99
L.5	Parameters for execution.....	100
L.5.1	Service category.....	100
L.5.2	Calculation of utilisation grade.....	101
Bibliography	103

Foreword

This document (EN 1999-1-3:2007) has been prepared by Technical Committee CEN/TC 250 “Structural Eurocodes”, the secretariat of which is held by BSI.

This European Standard shall be given the status of a national standard, either by publication of an identical text or by endorsement, at the latest by November 2007, and conflicting national standards shall be withdrawn at the latest by March 2010.

This European Standard supersedes ENV 1999-2: 1998.

According to the CEN/CENELEC Internal Regulations, the national standards organizations of the following countries are bound to implement this European Standard:

Austria, Belgium, Bulgaria, Cyprus, Czech Republic, Denmark, Estonia, Finland, France, Germany, Greece, Hungary, Iceland, Ireland, Italy, Latvia, Lithuania, Luxemburg, Malta, Netherlands, Norway, Poland, Portugal, Romania, Slovakia, Slovenia, Spain, Sweden, Switzerland and the United Kingdom.

Background to the Eurocode programme

In 1975, the Commission of the European Community decided on an action programme in the field of construction, based on article 95 of the Treaty. The objective of the programme was the elimination of technical obstacles to trade and the harmonisation of technical specifications.

Within this action programme, the Commission took the initiative to establish a set of harmonised technical rules for the design of construction works, which in a first stage would serve as an alternative to the national rules in force in the Member States and, ultimately, would replace them.

For fifteen years, the Commission, with the help of a Steering Committee with Representatives of Member States, conducted the development of the Eurocodes programme, which led to the first generation of European codes in the 1980s.

In 1989, the Commission and the Member States of the EU and EFTA decided, on the basis of an agreement¹⁾ between the Commission and CEN, to transfer the preparation and the publication of the Eurocodes to the CEN through a series of Mandates, in order to provide them with a future status of European Standard (EN). This links de facto the Eurocodes with the provisions of all the Council's Directives and/or Commission's Decisions dealing with European standards (e.g. the Council Directive 89/106/EEC on construction products – CPD – and Council Directives 93/37/EEC, 92/50/EEC and 89/440/EEC on public works and services and equivalent EFTA Directives initiated in pursuit of setting up the internal market).

The Structural Eurocode programme comprises the following standards generally consisting of a number of Parts:

EN 1990 Eurocode 0: Basis of structural design

EN 1991 Eurocode 1: Actions on structures

EN 1992 Eurocode 2: Design of concrete structures

EN 1993 Eurocode 3: Design of steel structures

1) Agreement between the Commission of the European Communities and the European Committee for Standardisation (CEN) concerning the work on EUROCODES for the design of building and civil engineering works (BC/CEN/03/89).

EN 1994 Eurocode 4: Design of composite steel and concrete structures

EN 1995 Eurocode 5: Design of timber structures

EN 1996 Eurocode 6: Design of masonry structures

EN 1997 Eurocode 7: Geotechnical design

EN 1998 Eurocode 8: Design of structures for earthquake resistance

EN 1999 Eurocode 9: Design of aluminium structures

Eurocode standards recognise the responsibility of regulatory authorities in each Member State and have safeguarded their right to determine values related to regulatory safety matters at national level where these continue to vary from State to State.

Status and field of application of Eurocodes

The Member States of the EU and EFTA recognise that Eurocodes serve as reference documents for the following purposes:

- As a means to prove compliance of building and civil engineering works with the essential requirements of Council Directive 89/106/EEC, particularly Essential Requirement N^o1 - Mechanical resistance and stability - and Essential Requirement N^o2 - Safety in case of fire;
- as a basis for specifying contracts for construction works and related engineering services;
- as a framework for drawing up harmonised technical specifications for construction products (ENs and ETAs).

The Eurocodes, as far as they concern the construction works themselves, have a direct relationship with the Interpretative Documents²⁾ referred to in Article 12 of the CPD, although they are of a different nature from harmonised product standard³⁾. Therefore, technical aspects arising from the Eurocodes work need to be adequately considered by CEN Technical Committees and/or EOTA Working Groups working on product standards with a view to achieving a full compatibility of these technical specifications with the Eurocodes.

The Eurocode standards provide common structural design rules for everyday use for the design of whole structures and component products of both a traditional and an innovative nature. Unusual forms of construction or design conditions are not specifically covered and additional expert consideration will be required by the designer in such cases.

2) According to Art. 3.3 of the CPD, the essential requirements (ERs) shall be given concrete form in interpretative documents for the creation of the necessary links between the essential requirements and the mandates for hENs and ETAGs/ETAs.

3) According to Art. 12 of the CPD the interpretative documents shall:

- a) give concrete form to the essential requirements by harmonising the terminology and the technical bases and indicating classes or levels for each requirement where necessary;
- b) indicate methods of correlating these classes or levels of requirement with the technical specifications, e.g. methods of calculation and of proof, technical rules for project design, etc.;
- c) serve as a reference for the establishment of harmonised standards and guidelines for European technical approvals. The Eurocodes, de facto, play a similar role in the field of the ER 1 and a part of ER 2.

National Standards implementing Eurocodes

The National Standards implementing Eurocodes will comprise the full text of the Eurocode (including any annexes), as published by CEN, which may be preceded by a National title page and National foreword, and may be followed by a National Annex (informative).

The National Annex (informative) may only contain information on those parameters which are left open in the Eurocode for national choice, known as Nationally Determined Parameters, to be used for the design of buildings and civil engineering works to be constructed in the country concerned, i.e.:

- Values for partial factors and/or classes where alternatives are given in the Eurocode;
- values to be used where a symbol only is given in the Eurocode;
- geographical and climatic data specific to the Member State, e.g. snow map;
- the procedure to be used where alternative procedures are given in the Eurocode;
- references to non-contradictory complementary information to assist the user to apply the Eurocode.

Links between Eurocodes and product harmonised technical specifications (ENs and ETAs)

There is a need for consistency between the harmonised technical specifications for construction products and the technical rules for works⁴⁾. Furthermore, all the information accompanying the CE Marking of the construction products which refer to Eurocodes should clearly mention which Nationally Determined Parameters have been taken into account.

Additional information specific to EN 1999-1-3

EN 1999 is intended to be used with Eurocodes EN 1990 – Basis of Structural Design, EN 1991 – Actions on structures and EN 1992 to EN 1999, where aluminium structures or aluminium components are referred to.

EN 1999-1-3 is one of five parts EN 1999-1-1 to EN 1999-1-5 each addressing specific aluminium components, limit states or type of structure. EN 1999-1-3 describes the principles, requirements and rules for the structural design of aluminium components and structures subjected to fatigue actions.

Numerical values for partial factors and other reliability parameters are recommended as basic values that provide an acceptable level of reliability. They have been selected assuming that an appropriate level of workmanship and quality management applies.

Foreword to amendment A1

This document (EN 1999-1-3:2007/A1:2011) has been prepared by Technical Committee CEN/TC 250 “Structural Eurocodes”, the secretariat of which is held by BSI.

This Amendment to the European Standard EN 1999-1-3:2007 shall be given the status of a national standard, either by publication of an identical text or by endorsement, at the latest by August 2012, and conflicting national standards shall be withdrawn at the latest by August 2012.

Attention is drawn to the possibility that some of the elements of this document may be the subject of patent rights. CEN [and/or CENELEC] shall not be held responsible for identifying any or all such patent rights.

According to the CEN/CENELEC Internal Regulations, the national standards organizations of the following countries are bound to implement this European Standard: Austria, Belgium, Bulgaria, Croatia, Cyprus, Czech Republic, Denmark, Estonia, Finland, France, Germany, Greece, Hungary, Iceland, Ireland, Italy, Latvia, Lithuania, Luxembourg, Malta, Netherlands, Norway, Poland, Portugal, Romania, Slovakia, Slovenia, Spain, Sweden, Switzerland and the United Kingdom.

National Annex for EN 1999-1-3

This standard gives alternative procedures, values and recommendations for classes with NOTES indicating where national choices may have to be made. Therefore the National Standard implementing EN 1999-1-1 should have a National Annex containing all Nationally Determined Parameters to be used for the design of aluminium structures to be constructed in the relevant country.

4) See Art.3.3 and Art.12 of the CPD, as well as clauses 4.2, 4.3.1, 4.3.2 and 5.2 of ID 1. Construction products which refer to Eurocodes should clearly mention which Nationally Determined Parameters have been taken into account.

National choice is allowed in EN 1999-1-3 through clauses:

- Ⓐ₁ — 2.1.1 (1)
- 2.2.1 (4)
- 2.3.1 (2) Ⓐ₁
- 2.3.2 (6)
- 2.4 (1)
- 3 (1)
- 4 (2)
- 5.8.1 (1)
- 5.8.2 (1)
- 6.1.3 (1)
- 6.2.1(2)
- 6.2.1 (7)
- 6.2.1 (11)
- Ⓐ₁ *Text deleted* Ⓐ₁
- E (5)
- E (7)
- I.2.2 (1)
- I.2.3.2 (1)
- I.2.4 (1).

1 General

1.1 Scope

1.1.1 Scope of EN 1999

(1) P EN 1999 applies to the design of buildings and civil engineering and structural works in aluminium. It complies with the principles and requirements for the safety and serviceability of structures, the basis of their design and verification that are given in EN 1990 – Basis of structural design.

(2) EN 1999 is only concerned with requirements for resistance, serviceability, durability and fire resistance of aluminium structures. Other requirements, e.g. concerning thermal or sound insulation, are not considered.

(3) EN 1999 is intended to be used in conjunction with:

- EN 1990 Basis of structural design
- EN 1991 Actions on structures
- European Standards for construction products relevant for aluminium structures
- EN 1090-1: Execution of steel structures and aluminium structures – Part 1: Conformity assessment of structural components⁵⁾
- EN 1090-3: Execution of steel structures and aluminium structures – Part 3: Technical requirements for aluminium structures⁶⁾

(4) EN 1999 is subdivided in five parts:

EN 1999-1-1 Design of Aluminium Structures: General structural rules

EN 1999-1-2 Design of Aluminium Structures: Structural fire design

EN 1999-1-3 Design of Aluminium Structures: Structures susceptible to fatigue

EN 1999-1-4 Design of Aluminium Structures: Cold-formed structural sheeting

EN 1999-1-5 Design of Aluminium Structures: Shell structures

1.1.2 Scope of EN 1999-1-3

(1) EN 1999-1-3 gives the basis for the design of aluminium alloy structures with respect to the limit state of fracture induced by fatigue.

(2) EN 1999-1-3 gives rules for:

- Safe life design;
- damage tolerant design;
- design assisted by testing.

5) To be published

6) To be published

(3) EN 1999-1-3 is intended to be used in conjunction with EN 1090-3 “Technical requirements for the execution of aluminium structures” which contains the requirements necessary for the design assumptions to be met during execution of components and structures.

(4) EN 1999-1-3 does not cover pressurised containment vessels or pipe-work.

(5) The following subjects are dealt with in EN 1999-1-3:

Section 1: General

Section 2: Basis of design

Section 3: Materials, constituent products and connecting devices

Section 4: Durability

Section 5: Structural analysis

Section 6: Ultimate limit state of fatigue

Annex A: Basis for calculation of fatigue resistance [normative]

Annex B: Guidance on assessment by fracture mechanics [informative]

Annex C: Testing for fatigue design [informative]

Annex D: Stress analysis [informative]

Annex E: Adhesively bonded joints [informative]

Annex F: Low cycle fatigue range [informative]

Annex G: Influence of R-ratio [informative]

Annex H: Fatigue strength improvement of welds [informative]

Annex I: Castings [informative]

Annex J: Detail category tables [informative]

Annex K: Hot spot reference detail method [informative]

Bibliography

1.2 Normative references

(1) The normative references of EN 1999-1-1 apply.

1.3 Assumptions

(1) P The general assumptions of EN 1990, 1.3 apply.

(2) P The provisions of EN 1999-1-1, 1.8 apply.

(3) P The design procedures are valid only when the requirements for execution in EN 1090-3 or other equivalent requirements are complied with.

1.4 Distinction between principles and application rules

(1) P The rules in EN 1990, 1.4 apply.

1.5 Terms and definitions

1.5.1 General

(1) The rules in EN 1990, 1.5 apply.

1.5.2 Additional terms used in EN 1999-1-3

(1) For the purpose of this European Standard the following terms and definitions in addition to those defined in EN 1990 and EN 1999-1-1 apply.

1.5.2.1

fatigue

weakening of a structural part, through crack initiation and propagation caused by repeated stress fluctuations

1.5.2.2

fatigue loading

a set of typical load events described by the positions or movements of actions, their variation in intensity and their frequency and sequence of occurrence

1.5.2.3

loading event

a defined load sequence applied to the structure, which, for design purposes, is assumed to repeat at a given frequency

1.5.2.4

nominal stress

a stress in the parent material adjacent to a potential crack location, calculated in accordance with simple elastic strength of materials theory, i.e. assuming that plane sections remain plane and that all stress concentration effects are ignored

1.5.2.5

modified nominal stress

A nominal stress increased by an appropriate geometrical stress concentration factor K_{gt} , to allow only for geometric changes of cross section which have not been taken into account in the classification of a particular constructional detail

1.5.2.6

geometric stress

also known as structural stress, is the elastic stress at a point, taking into account all geometrical discontinuities, but ignoring any local singularities where the transition radius tends to zero, such as notches due to small discontinuities, e.g. weld toes, cracks, crack like features, normal machining marks etc. It is in principle the same stress parameter as the modified nominal stress, but generally evaluated by a different method

1.5.2.7

geometric stress concentration factor

the ratio between the geometric stress evaluated with the assumption of linear elastic behaviour of the material and the nominal stress

1.5.2.8

hot spot stress

the geometric stress at a specified initiation site in a particular type of geometry, such as a weld toe in an angle hollow section joint, for which the fatigue strength, expressed in terms of the hot spot stress range, is usually known

1.5.2.9

stress history

a continuous chronological record, either measured or calculated, of the stress variation at a particular point in a structure for a given period of time

1.5.2.10

stress turning point

the value of stress in a stress history where the rate of change of stress changes sign

1.5.2.12

stress peak

a turning point where the rate of change of stress changes from positive to negative

1.5.2.12

stress valley

a turning point where the rate of change of stress changes from negative to positive

1.5.2.13

constant amplitude

relating to a stress history where the stress alternates between stress peaks and stress valleys of constant values

1.5.2.14

variable amplitude

relating to any stress history containing more than one value of peak or valley stress

1.5.2.15

stress cycle

part of a constant amplitude stress history where the stress starts and finishes at the same value but, in doing so passes through one stress peak and one stress valley (in any sequence). Also, a specific part of a variable amplitude stress history as determined by a cycle counting method

1.5.2.16

cycle counting

the process of transforming a variable amplitude stress history into a spectrum of stress cycles, each with a particular stress range, e.g. the 'Reservoir' method and the 'Rain flow' method

1.5.2.17

rainflow method

particular cycle counting method of producing a stress-range spectrum from a given stress history

1.5.2.18

reservoir method

particular cycle counting method of producing a stress-range spectrum from a given stress history

1.5.2.19

stress amplitude

half the value of the stress range

1.5.2.20

stress ratio

minimum stress divided by the maximum stress in a constant amplitude stress history or a cycle derived from a variable amplitude stress history

1.5.2.21

stress intensity ratio

minimum stress intensity divided by the maximum stress intensity derived from a constant amplitude stress history or a cycle from a variable amplitude stress history

1.5.2.22**mean stress**

the mean value of the algebraic sum of maximum and minimum stress values

1.5.2.23**stress range**

the algebraic difference between the stress peak and the stress valley in a stress cycle

1.5.2.24**stress intensity range**

the algebraic difference between the maximum stress intensity and the minimum stress intensity derived from the stress peak and the stress valley in a stress cycle

1.5.2.25**stress-range spectrum**

histogram of the frequency of occurrence for all stress ranges of different magnitudes recorded or calculated for a particular load event (also known as 'stress spectrum')

1.5.2.26**design spectrum**

the total of all stress-range spectra relevant to the fatigue assessment

1.5.2.27**detail category**

the designation given to a particular fatigue initiation site for a given direction of stress fluctuation in order to indicate which fatigue strength curve is applicable for the fatigue assessment

1.5.2.28**endurance**

the life to failure expressed in cycles, under the action of a constant amplitude stress history

1.5.2.29**fatigue strength curve**

the quantitative relationship relating stress range and endurance, used for the fatigue assessment of a category of constructional detail, plotted with logarithmic axes in this standard

1.5.2.30**reference fatigue strength**

the constant amplitude stress range $\Delta\sigma_c$ for a particular detail category for an endurance $N_C = 2 \times 10^6$ cycles

1.5.2.31**constant amplitude fatigue limit**

the stress range below which value all stress ranges in the design spectrum should lie for fatigue damage to be ignored

1.5.2.32**cut-off limit**

limit below which stress ranges of the design spectrum may be omitted from the cumulative damage calculation

1.5.2.33**design life**

the reference period of time for which a structure is required to perform safely with an acceptable probability that structural failure by fatigue cracking will not occur

A1 1.5.2.34**safe life**

period of time for which a structure is estimated to perform safely with an acceptable probability that failure by fatigue cracking will not occur, when using the safe life design method **A1**

1.5.2.35

damage tolerance

ability of the structure to accommodate fatigue cracking without structural failure or unserviceability

1.5.2.36

fatigue damage

the ratio of the number of cycles of a given stress range which is required to be sustained during a specified period of service to the endurance of the constructional detail under the same stress range

1.5.2.37

miner's summation

the summation of the damage due to all cycles in a stress-range spectrum (or a design spectrum), based on the Palmgren-Miner rule

1.5.2.38

equivalent fatigue loading

a simplified loading, usually a single load applied a prescribed number of times in such a way that it may be used in place of a more realistic set of loads, within a given range of conditions, to give an equivalent amount of fatigue damage, to an acceptable level of approximation

1.5.2.39

equivalent stress range

the stress range at a constructional detail caused by the application of an equivalent fatigue load

1.5.2.40

equivalent constant amplitude loading

simplified constant amplitude loading causing the same fatigue damage effects as a series of actual variable amplitude load events

1.6 Symbols

A	constant in the crack growth relationship
a	fillet weld throat
a	crack length
a_c	crack width on surface
da/dN	crack growth rate (m/cycle)
D	fatigue damage value calculated for a given period of service
D_L	fatigue damage value calculated for the full design life
D_{lim}	prescribed limit of the fatigue damage value
$f_{v,adh}$	characteristic shear strength of adhesive
K_{gt}	geometric stress concentration factor
K	stress intensity factor
ΔK	stress intensity range
k_{adh}	fatigue strength factor for adhesive joints

k_F	number of standard deviations above mean predicted intensity of loading
k_N	number of standard deviations above mean predicted number of cycles of loading
L_{adh}	effective length of adhesively bonded lap joints
l_d	minimum detectable length of crack
l_f	fracture critical length of crack
\log	logarithm to base 10
$\boxed{A_1} m$	inverse slope of $\log\Delta\sigma$ - $\log N$ fatigue strength curve, or respectively crack growth rate exponent $\boxed{A_1}$
m_1	value of m for $N \leq 5 \times 10^6$ cycles
m_2	value of m for $5 \times 10^6 < N \leq 10^8$ cycles
N	number (or total number) of stress range cycles
$\boxed{A_1} N_i$	predicted number of cycles to failure of a stress range $\Delta\sigma_i$ $\boxed{A_1}$
N_C	number of cycles (2×10^6) at which the reference fatigue strength is defined
N_D	number of cycles (5×10^6) at which the constant amplitude fatigue limit is defined
N_L	number of cycles (10^8) at which the cut-off limit is defined
n_i	number of cycles of stress range $\Delta\sigma_i$
P	probability
R	stress ratio
t	thickness
$\boxed{A_1} T_i$	inspection interval
T_F	recommended time after completed erection for the start of fatigue inspection, where the fatigue inspection comprises the inspection of areas with high probability for cracks
T_G	recommended time after completed erection for start of general inspection, where the general inspection comprises checking that the structure is as it was when it was completed and approved, i.e. that no deterioration has taken place, such as deterioration caused by adding detrimental holes or welds for additional elements, damage due to vandalism or accidents, unexpected corrosion etc $\boxed{A_1}$
T_f	time for a crack to grow from a detectable size to a fracture critical size
T_L	design life
T_S	safe life
y	crack geometry factor in crack growth relationship
$\boxed{A_1} \lambda_i$	damage equivalent factor depending on the load situation and the structural characteristics as well as other factors
γ_{Fr}	partial factor for fatigue load intensity
γ_{Mf}	partial factor for fatigue strength $\boxed{A_1}$

$\Delta\sigma$	nominal stress range (normal stress)
NOTE	$\Delta\sigma$ refers either to action effects or to fatigue strength depending on context.
$\Delta\tau$	effective shear stress range
$\Delta\sigma_i$	constant stress range for the principal stresses in the construction detail for n_i cycles
$\Delta\sigma_C$	reference fatigue strength at 2×10^6 cycles (normal stress)
$\Delta\sigma_D$	constant amplitude fatigue limit
$\Delta\sigma_E$	nominal stress range from fatigue actions
$\Delta\sigma_{E,Ne}$	equivalent constant amplitude stress range related to N_{max}
$\Delta\sigma_{E,2e}$	equivalent constant amplitude stress range related to 2×10^6 cycles
$\Delta\sigma_L$	cut-off limit
$\Delta\sigma_R$	fatigue strength (normal stress)
ΔT_F	recommended maximum time interval for general inspection
ΔT_G	recommended maximum time interval for fatigue inspection
$\sigma_{max}, \sigma_{min}$	maximum and minimum values of the fluctuating stresses in a stress cycle
σ_m	mean stress
$D_{L,d}$	design fatigue damage value calculated for the full design life \square_{A1}

1.7 Specification for execution

1.7.1 Execution specification

(1) The execution specification should include all requirements for material preparation, assembly, joining, post treatment and inspection in order that the required fatigue strengths are achieved.

1.7.2 Operation manual

(1) The operation manual should include:

- Details of the fatigue loading and the design life assumed in the design;
- any necessary requirements to monitor loading intensity and frequency during service;
- an instruction forbidding any modification of the structure, e.g. making of holes or welding, without qualified analysis of any structural consequences;
- instructions for dismantling and reassembly of parts, e.g. tightening of fasteners;
- acceptable repair methods in the event of accidental damage in-service (e.g. dents, penetrations, tears, etc).

1.7.3 Inspection and maintenance manual

(1) The maintenance manual should include a schedule of any necessary in-service inspection of fatigue critical parts. In particular, where damage tolerant design has been used, this should include:

- The methods of inspection;
- the locations for inspection;
- the frequency of inspections;
- the maximum permissible crack size before correction is necessary;
- details of methods of repair or replacement of fatigue cracked parts.

A1 2 Basis of design

2.1 General

2.1.1 Basic requirements

(1) P The aim of designing a structure against the limit state of fatigue is to ensure, with an acceptable level of probability, that its performance is satisfactory during its entire design life, such that the structure shall not fail by fatigue nor shall it be likely to require undue repair of damage caused by fatigue during the design life. The design of aluminium structures against the limit state of fatigue may be based on one of following methods:

- a) safe life design (SLD) (see 2.2.1);
- b) damage tolerant design (DTD) (see 2.2.2).

Either of methods a) and b) may be supplemented or replaced by design assisted by testing (see 2.2.3).

NOTE The national annex may specify conditions for the application for the above methods of design.

(2) The method for design against fatigue should be selected taking the use of the structure into account, considering the consequence class fixed for the components of the structure. In particular the accessibility for inspection of components and details where fatigue cracks are likely to occur should be considered.

(3) Fatigue assessment of components and structures should be considered in cases where the loads are frequently changing, particularly if reversing. Common situations where this may occur are e.g.:

- members supporting lifting appliances or rolling loads;
- members subjected to repeated stress cycles from vibrating machinery;
- members subjected to wind-induced oscillations;
- members subject to crowd-induced oscillations;
- moving structures (structures subject to inertia forces);
- members subjected to fluid flow induced oscillations or wave action.

NOTE The rules for fatigue resistance given in this standard apply generally to high cycle fatigue. For low cycle fatigue, guidelines are given in Annex F.

(4) The design rules in the other parts of EN 1999 apply.

2.2 Procedures for fatigue design

2.2.1 Safe life design (SLD)

(1) The safe life design method is based on the calculation of damage accumulation during the structure's design life or comparing the maximum stress range with the constant amplitude limit, using standard lower bound endurance data and an upper bound estimate of the fatigue loading, all based on design values. The approach provides a conservative estimate of the fatigue strength and does not normally depend on in-service inspection for fatigue damage.

NOTE Options considering in-service inspection are given in L1 for use when Annex J resistance data is adopted.

(2) The fatigue design involves prediction of the stress histories at potential crack initiation sites, followed by counting of load cycles with the associated stress ranges and compilation of stress spectra. From this information an estimate of the design life is made using the appropriate stress range endurance data for the construction detail concerned. This method is given in A.2. **A1**

A1 (3) The safe life design method may be based on one of two procedures to ensure sufficient resistance of the component or structure. The procedures are respectively based on that

- a) the linear damage accumulation calculation is used, see (4);
- b) the equivalent stress range approach is used, see (5)

NOTE A third procedure, for the case where all design stress ranges are less than the design constant amplitude fatigue limit, is given in L.1(4).

(4) For safe life design based on the assumption of linear damage accumulation (Palmgren-Miner's summation) the damage value D_L for all cycles should fulfill the condition:

$$D_{L,d} \leq 1 \quad (2.1 \text{ a})$$

where

$D_{L,d} = \sum n_i / N_i$ is calculated in accordance with the procedure given in A.2.

or

$$D_L \leq D_{lim} \quad (2.1 \text{ b})$$

where:

$D_L = \sum n_i / N_i$ is calculated in accordance with the procedure given in A.2 with $\gamma_{Mf} = \gamma_{Ft} = 1,0$.

NOTE The national annex may specify values for D_{lim} , see L.4. Recommended values of D_{lim} are given in L.4 for use when resistance data in Annex J is adopted.

(5) In case the design is based on the equivalent stress range approach ($\Delta\sigma_{E,2e}$) the following condition should be fulfilled:

$$\frac{\gamma_{Ft} \Delta\sigma_{E,2e}}{\Delta\sigma_C / \gamma_{Mf}} \leq 1 \quad (2.2)$$

NOTE Recommended values for γ_{Mf} are given in L.4. For γ_{Ft} , see 2.4.

2.2.2 Damage tolerant design (DTD)

(1) P A damage tolerant design requires that a prescribed inspection and maintenance programme for detecting and correcting any fatigue damage is prepared and followed throughout the design life of the structure. It should provide an acceptable reliability that a structure will perform satisfactorily for its design life. Prerequisites for use of this method and determination of an inspection strategy are given in A.3.

NOTE 1 Damage tolerant design may be suitable for application where a safe life assessment shows that fatigue has a significant effect on design economy and where a higher risk of fatigue cracking during the design life may be justified than is permitted using safe life design principles. The approach is intended to result in the same reliability level as obtained by using the approach of safe life design.

NOTE 2 Damage tolerant design may be applied in two different types of approach, DTD-I and DTD-II, see Annex L.

(2) The following guidelines should be considered for the structural layout and detailing: **A1**

- A1 — select details, material and stress levels so that in the event of the formation of cracks a low rate of crack propagation and a long critical crack length would result;
- choose wherever possible a structural concept where in the event of fatigue damage a redistribution of load effects within the structure or within the cross section of a member can occur (principle of redundancy);
- provide crack-arresting details;
- assure that critical components and details are readily inspectable during regular inspection;
- ensure that cracks can be kept under control by monitoring or, if needed, that components are readily repairable or replaceable.

2.2.3 Design assisted by testing

(1) This approach should be used where the necessary loading data, response data, fatigue strength data or crack growth data are not available from standards or other sources for a particular application, and for optimisation of construction details. Test data should only be used in lieu of standard data on condition that they are obtained and applied under controlled conditions.

NOTE Verification of design by testing should be carried out in accordance with Annex C.

2.3 Fatigue loading

2.3.1 Sources of fatigue loading

(1) P All sources of fluctuating stress in the structure should be identified. Common fatigue loading situations are given in 2.1.1.

NOTE For limitation of fatigue induced by repeated local buckling, see D.3.

(2) The fatigue loading should be obtained from EN 1991 or other relevant European Standard.

NOTE The national annex may give rules for the determination of the fatigue loads for cases not covered by a European Standard.

(3) Dynamic effects should be taken into account unless already allowed for in the fatigue load effects.

2.3.2 Derivation of fatigue loading

(1) In addition to the fatigue loading standards the following clauses should be considered:

(2) Loading for fatigue should normally be described in terms of a design load spectrum, which defines a range of intensities of a specific live load event and the number of times that each intensity level is applied during the structure's design life. If two or more independent live load events are likely to occur then it will be necessary to specify the phasing between them.

(3) Realistic assessment of the fatigue loading is crucial to the calculation of the life of the structure. Where no published data for live load exists, fatigue loading data from existing structures subjected to similar load effects should be used.

(4) By recording continuous strain or deflection measurements over a suitable sampling period, fatigue loading data should be inferred from subsequent analysis of the structural responses. Particular care should be taken to assess dynamic magnification effects where load frequencies are close to one of the natural frequencies of the structure.

NOTE Further guidance is given in Annex C. A1

A1 (5) The design load spectrum should be selected on the basis that it is an upper bound estimate of the accumulated service conditions over the full design life of the structure. Account should be taken of all likely operational and exposure condition effects arising from the foreseeable usage of the structure during that period.

(6) The confidence limit to be used for the intensity of the design load spectrum should be based on the mean predicted value plus k_F standard deviations. The confidence limit to be used for the number of cycles in the design load spectrum should be based on the mean predicted value plus k_N standard deviations.

NOTE Values of k_F and k_N may be defined in the national annex. The numerical values $k_F = 2$, and $k_N = 2$ are recommended. See also NOTE 2 under 2.4 (1).

2.3.3 Equivalent fatigue loading

(1) A simplified equivalent fatigue loading may be used if the following conditions are satisfied:

- a) the structure falls within the range of basic structural forms and size for which the equivalent fatigue loading was originally derived;
- b) the real fatigue loading is of similar intensity and frequency and is applied in a similar way to that assumed in the derivation of the equivalent fatigue loading;
- c) the values of m_1 , m_2 , N_D and N_L , see Figure 6.1, assumed in the derivation of equivalent fatigue loading are the same as those appropriate to the construction detail being assessed;

NOTE Some equivalent fatigue loads may have been derived assuming a simple continuous slope where $m_2 = m_1$ and $\Delta\sigma_L = 0$. For many applications involving numerous low amplitude cycles this will result in a very conservative estimate of life.

- d) the dynamic response of the structure is sufficiently low that the resonant effects, which will be affected by differences in mass, stiffness and damping coefficient, will have little effect on the overall Palmgren-Miner summation.

(2) In the event that an equivalent fatigue loading is derived specifically for an aluminium alloy structural application, all the matters addressed in (1) above should be taken into account.

2.4 Partial factors for fatigue loads

(1) Where the fatigue loads F_{Ek} have been derived in accordance with the requirements of 2.3.1 (2) and 2.3.2 a partial factor should be applied to the loads to obtain the design load F_{Ed} .

$$F_{Ed} = \gamma_{ff} F_{Ek} \quad (2.4)$$

where

γ_{ff} is the partial factor for fatigue loads.

NOTE 1 The partial factors may be defined in the national annex. A value of $\gamma_{ff} = 1,0$ is recommended.

NOTE 2 Where fatigue loads have been based on confidence limits other than those in 2.3.2 (6), recommended values for partial factors on loads are given in Table 2.1. Alternative values may be specified in the national annex. **A1**

Table 2.1 — Recommended partial factors γ_{Ff} for intensity and number of cycles in the fatigue load spectrum

k_F	γ_{Ff}	
	$k_N = 0$	$k_N = 2$
0	1,5	1,4
1	1,3	1,2
2	1,1	1,0

2.5 Execution requirements

(1) EN 1090-3 requires execution classes to be selected. These may be related to service category.

NOTE Guidance on selection of execution class and service category is given in EN 1999-1-1. Guidance on utilization grade is given in L.5 for use when Annex J resistance data is adopted. **A1**

3 Materials, constituent products and connecting devices

(1) The design rules of EN 1999-1-3 apply to constituent products in components and structures as listed in 1999-1-1:05-2005 with the exception of the low strength alloys EN AW-3005, EN AW-3103, EN AW-5005, EN AW-8011A in all tempers, and EN AW-6060 in temper T5.

NOTE 1 For the above mentioned low strength alloys and tempers no reliable fatigue data exist. The National Annex may give fatigue data for such alloys and tempers, respectively. Tests to obtain the data should be carried out in accordance with Annex C.

NOTE 2 For castings see Annex I.

(2) EN 1999-1-3 covers components with open and hollow sections, including members built up from combinations of these products.

(3) EN 1999-1-3 covers components and structures with the following connecting devices:

- Arc welding (metal inert gas and tungsten inert gas);
- steel bolts listed in EN 1999-1-1, Table 3.4.

NOTE For adhesive bonding see Annex E.

(4) For the fatigue design and verification of steel bolts in tension and shear see EN 1993-1-9, Table 8.1.

4 Durability

(1) Fatigue strength data given in EN 1999-1-3 are applicable under normal atmospheric conditions up to temperatures of 100 °C. However in the case of alloy EN AW-5083, at temperatures of more than 65 °C fatigue strength data in EN 1999-1-3 do not apply unless an efficient corrosion preventing coating is provided.

(2) Fatigue strength data may not be applicable under all conditions of aggressive exposure. Guidance on materials and exposure conditions is given in 6.2 and 6.4.

NOTE The National Annex may give further information on durability, based on local exposure conditions.

(3) For adhesively bonded joints special environmental conditions and effects may have to be considered.

NOTE See Annex E.

5 Structural analysis

5.1 Global analysis

5.1.1 General

(1) The method of analysis should be selected so as to provide an accurate prediction of the elastic stress response of the structure to the specified fatigue action, so that the maximum and minimum stress peaks in the stress history are determined, see Figure 5.1.

NOTE An elastic model used for static assessment (for the ultimate or serviceability limit state) in accordance with EN 1990-1-1 may not necessarily be adequate for fatigue assessment.

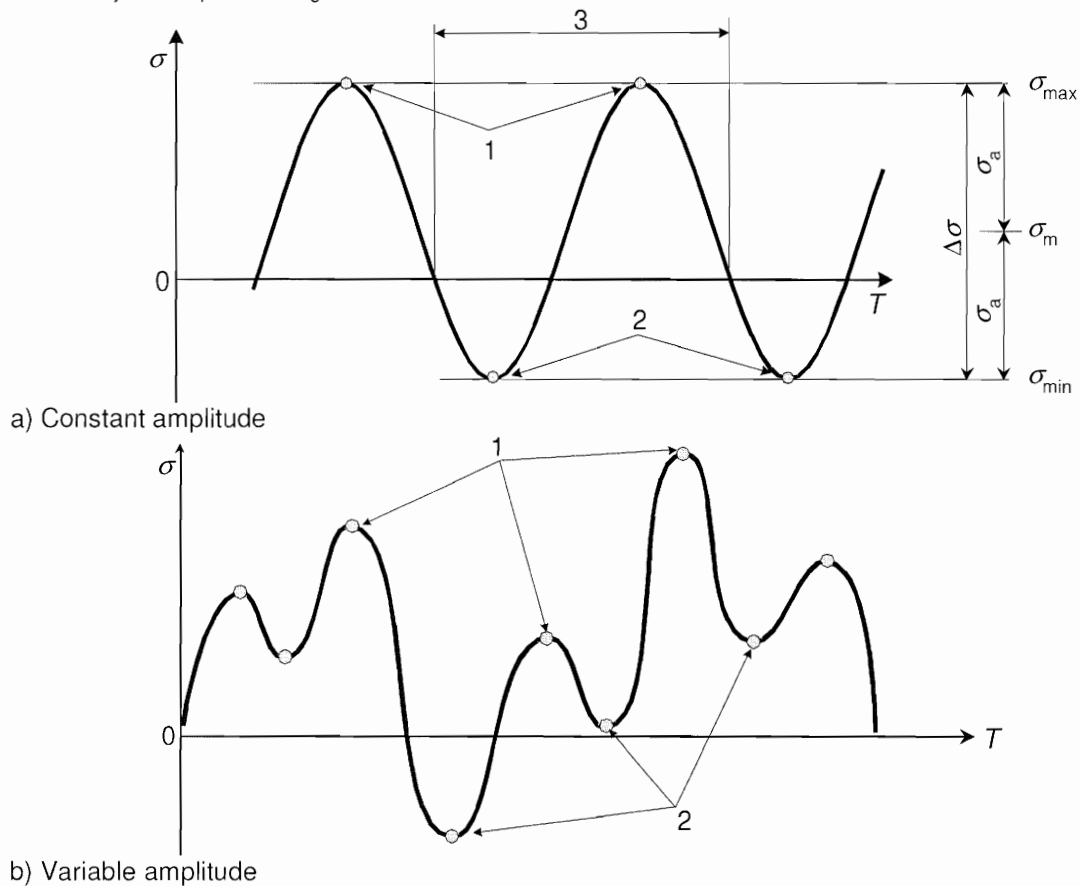

1 – stress peak; 2 – stress valley; 3 – stress cycle; o – stress turning point

σ_{\max} : maximum stress; σ_{\min} : minimum stress; σ_m : mean stress; $\Delta\sigma$: stress range; σ_a : stress amplitude

Figure 5.1 — Terminology relating to stress histories and cycles

(2) Dynamic effects should be included in the calculation of the stress history, except where an equivalent action is being applied which already allows for such effects.

(3) Where the elastic response is affected by the degree of damping this should be determined by test.

NOTE See Annex C.

(4) No plastic redistribution of forces between members should be assumed in statically indeterminate structures.

(5) The stiffening effect of any other materials which are permanently fixed to the aluminium structure should be taken into account in the elastic analysis.

(6) Models for global analysis of statically indeterminate structures and latticed frames with rigid or semi rigid joints (e.g. finite element models) should be based on elastic material behaviour, except where strain data have been obtained from prototype structures or accurately scaled physical models.

NOTE The term finite element is used to express analytical techniques where structural members and joints are represented by arrangements of bar, beam, membrane shell, solid or other element forms. The purpose of the analysis is to find the state of stress where displacement compatibility and static (or dynamic) equilibrium are maintained.

5.1.2 Use of beam elements

(1) Beam elements should be applicable to the global analysis of beam, framed or latticed structures subject to the limitations in (2) to (7) below.

(2) Beam elements should not be used for the fatigue analysis of stiffened plate structures of flat or shell type members or for cast or forged members unless of simple prismatic form.

(3) The axial, bending, shear and torsional section stiffness properties of the beam elements should be calculated in accordance with linear elastic theory assuming plane sections remain plane. However warping of the cross-section due to torsion should be considered.

(4) Where beam elements are used in structures with open section members or hollow section members prone to warping, which are subjected to torsional forces, the elements should have a minimum of 7 degrees of freedom including warping. Alternatively, shell elements should be used to model the cross-section.

(5) The section properties for the beam elements adjacent to member intersections should take into account the increased stiffness due to the size of the joint region and the presence of additional components (e.g. gussets, splice plates, etc.).

(6) The stiffness properties of beam elements used to model joint regions at angled intersections between open or hollow members where their cross-sections are not carried fully through the joint (e.g. unstiffened tubular nodes), or where the constructional detail is semi-rigid (e.g. bolted end plate or angle cleat connections), should be assessed either using shell elements or by connecting the elements via springs. The springs should possess sufficient stiffness for each degree of freedom and their stiffness should be determined either by tests or by shell element models of the joint.

(7) Where beam elements are used to model a structure with eccentricities between member axes at joints or where actions and restraints are applied to members other than at their axes, rigid link elements should be used at these positions to maintain the correct static equilibrium. Similar springs as in (6) should be used if necessary.

5.1.3 Use of membrane, shell and solid elements

(1) Membrane elements should only be applicable to those parts of a structure where out-of-plane bending stresses are known to be negligible.

(2) Shell elements should be applicable to all structural types except where cast, forged or machined members of complex shape involving 3-dimensional stress fields are used, in which case solid elements should be used.

(3) Where membrane or shell elements are used within the global analysis to take account of gross stress concentrating effects such as those listed in 5.2.2, the mesh size should be small enough in the part of the member containing the initiation site to assess the effect fully.

NOTE See Annex D.

5.2 Types of stresses

5.2.1 General

(1) Three different types of stresses may be used, namely:

- a) Nominal stresses, see 5.2.2. For derivation of nominal stress see 5.3.1;
- b) modified nominal stresses, see 5.2.3. For derivation of modified nominal stresses see 5.3.2;
- c) hot spot stresses, see 5.2.4 and 5.3.3.

5.2.2 Nominal stresses

(1) Nominal stresses, see Figure 5.2 should be used directly for the assessment of initiation sites in simple members and joints where the following conditions apply:

- a) the constructional details associated with the initiation site are represented by detail categories, or
- b) the detail category has been established by tests where the results have been expressed in terms of the nominal stresses;

NOTE Tests should be in accordance with Annex C.

- c) gross geometrical effects such as those listed in 5.2.3 are not present in the vicinity of the initiation site.

5.2.3 Modified nominal stresses

(1) Modified nominal stresses should be used in place of nominal stresses where the initiation site is in the vicinity of one or more of the following gross geometrical stress concentrating effects (see Figure 5.2) provided that conditions 5.2.1(a) and (b) still apply:

- a) Gross changes in cross section shape, e.g. at cut-outs or re-entrant corners;
- b) gross changes in stiffness around the member cross-section at unstiffened angled junctions between open or hollow sections;
- c) changes in direction or alignment beyond those permitted in detail category tables;
- d) shear lag in wide plate;

NOTE See EN 1999-1-1, K.1.

- e) distortion of hollow members;
- f) non-linear out-of-plane bending effects in slender flat plates, e.g. class 4 sections, where the static stress is close to the elastic critical stress, e.g. tension-field in webs.

NOTE See Annex D.

(2) The above geometrical stress concentrating effects should be taken into account through the factor K_{gt} , see Figure 5.2, defined as the theoretical stress concentration evaluated for linear elastic material omitting all the influences (local or geometric) already included in the $\Delta\sigma-N$ fatigue strength curve of the classified constructional detail considered as a reference.

5.2.4 Hot spot stresses

(1) Hot spot stresses may be used only where the following conditions apply:

- a) The initiation site is a weld toe in a joint with complex geometry where the nominal stresses are not clearly defined;

NOTE Due to the large influence of the heat affected zone in the strength of welded aluminium components, the experience from structural steel details is not generally applicable for aluminium.

- b) a hot spot detail category has been established by tests and the results have been expressed in terms of the hot spot stress, for the appropriate action mode;
- c) shell bending stresses are generated in flexible joints and taken into account according to 5.1.2 (6);

NOTE See Annexes C, D and K.

- d) for derivation of hot spot stresses see 5.3.3 and 6.2.4.

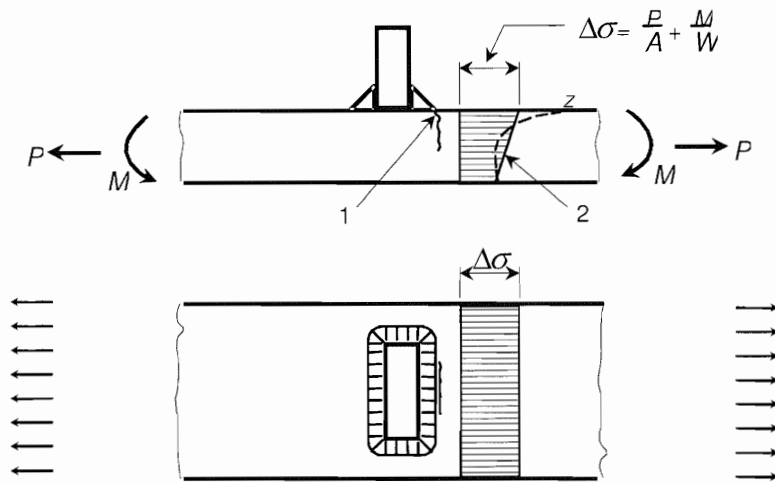

a) Local stress concentration at weld toe;

1 – crack initiation site; 2 – linear stress distribution, weld toe stress factor at z not calculated

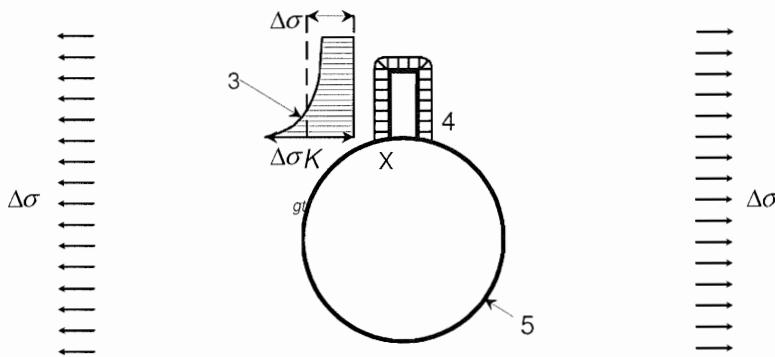

b) Gross stress concentration at large opening

$\Delta\sigma$ = nominal stress range; $\Delta\sigma K_{gt}$ = modified nominal stress range at initiation site X due to the opening; 3 – non-linear stress distribution; 4 – weld; 5 – large opening

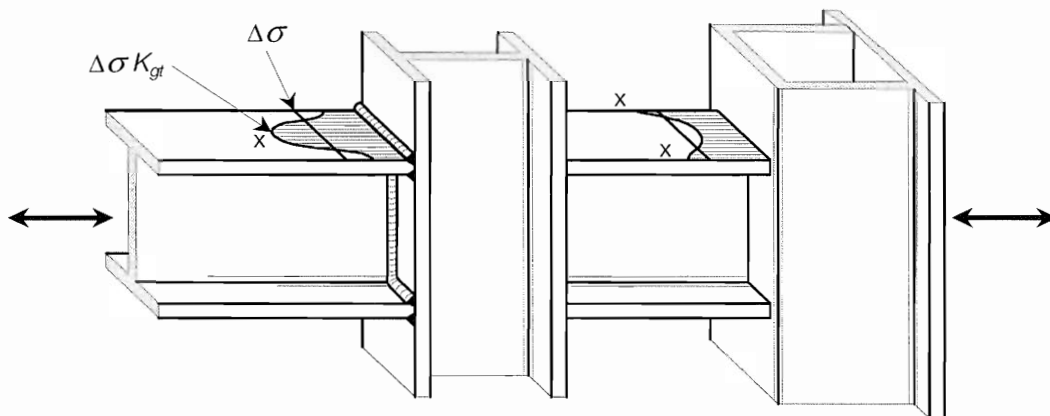

c) Hard point in connection;

$\Delta\sigma$ = nominal stress range; $\Delta\sigma K_{gt}$ = modified nominal stress range at initiation site X due to the geometrical stress concentration effects

Figure 5.2 – Examples of nominal and modified nominal stresses

5.3 Derivation of stresses

5.3.1 Derivation of nominal stresses

5.3.1.1 Structural models using beam elements

(1) The axial and shear stresses at the initiation site should be calculated from the axial, bending, shear and torsional action effects at the section concerned using linear elastic section properties.

(2) The cross-sectional areas and section moduli should take account of any specific requirements of a constructional detail.

5.3.1.2 Structural models using membrane, shell or solid elements

(1) Where the axial stress distribution is linear across the member section about both axes, the stresses at the initiation point may be used directly.

(2) Where the axial distribution is non-linear across the member section about either axis, the stresses across the section should be integrated to obtain the axial force and bending moments.

NOTE The latter should be used in conjunction with the appropriate cross-sectional area and section moduli to obtain the nominal stresses.

5.3.2 Derivation of modified nominal stresses

5.3.2.1 Structural models using beam elements

(1) The nominal stresses should be multiplied by the appropriate elastic stress concentration factors K_{gt} according to the location of the initiation site and the type of stress field.

(2) K_{gt} should take into account all geometrical discontinuities except for those already incorporated within the detail category.

(3) K_{gt} should be determined by one of the following approaches:

a) Standard solutions for stress concentration factors;

NOTE See D.2

b) substructuring of the surrounding geometry using shell elements taking into account (2), and applying the nominal stresses to the boundaries;

c) measurement of elastic strains on a physical model which incorporates the gross geometrical discontinuities, but excludes those features already incorporated within the detail category (see (2)).

5.3.2.2 Structural models using membrane, shell or solid elements

(1) Where the modified nominal stress is to be obtained from the global analysis in the region of the initiation site it should be selected on the following basis:

a) Local stress concentrations such as the classified constructional detail and the weld profile already included in the detail category should be omitted;

b) the mesh in the region of the initiation site should be fine enough to predict the general stress field around the site accurately but without incorporating the effects in (a)

NOTE See D.1.

5.3.3 Derivation of hot spot stresses

(1) The hot spot stress is the principal stress predominantly transverse to the weld toe line and should be evaluated in general by numerical or experimental methods, except where standard solutions are available.

NOTE See D.1.

(2) For simple cases, as the one shown in Figure 5.2 (c), the hot spot stress may be taken as the modified nominal stress and calculated according to 5.2.3.

(3) In general, for structural configurations for which standard stress concentration factors are not applicable and which therefore require special analysis, the fatigue stress at the weld toe should omit the stress concentration effects due to the classified constructional detail considered as a reference, i.e. the weld toe geometry.

5.3.4 Stress orientation

(1) The principal stress range is the greatest algebraic difference between the principal stresses acting in principal planes no more than 45° apart.

(2) For the purposes of assessing whether a constructional detail is normal or parallel to the axis of a weld if the direction of the principal tensile stress is less than 45° to the weld axis it should be assumed to be parallel to it.

5.4 Stress ranges for specific initiation sites

5.4.1 Parent material, welds, and mechanically fastened joints

(1) Cracks initiating from weld toes, weld caps, fastener holes, fraying surfaces, etc. and propagating through parent material or weld metal should be assessed using the nominal principal stress range in the member at that point (see Figure 5.3).

(2) The local stress concentration effects of weld profile, bolt and rivet holes are taken into account in the $\Delta\sigma$ - N strength data for the appropriate constructional detail category.

5.4.2 Fillet and partial penetration butt welds

(1) Cracks initiating from weld roots and propagating through the weld throat should be assessed using the vector sum $\Delta\sigma$ of the stresses in the weld metal based on the effective throat thickness, see Figure 5.3.

NOTE The reference strength value may be taken as in constructional detail 9.2, Table J.9.

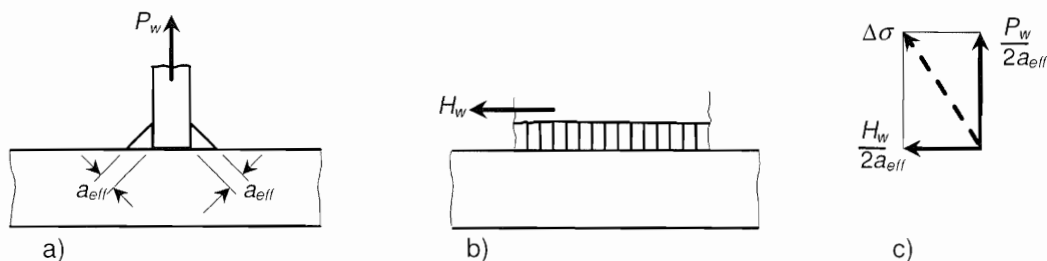

P_w and H_w are forces per unit length

Figure 5.3 —Stresses in weld throats

(2) In lapped joints in one plane the stress per unit length of weld may be calculated on the basis of the average area for axial forces and an elastic polar modulus of the weld group for in-plane moments (see Figure 5.4).

NOTE The reference strength value may be taken as in constructional detail 9.4, Table J.9.

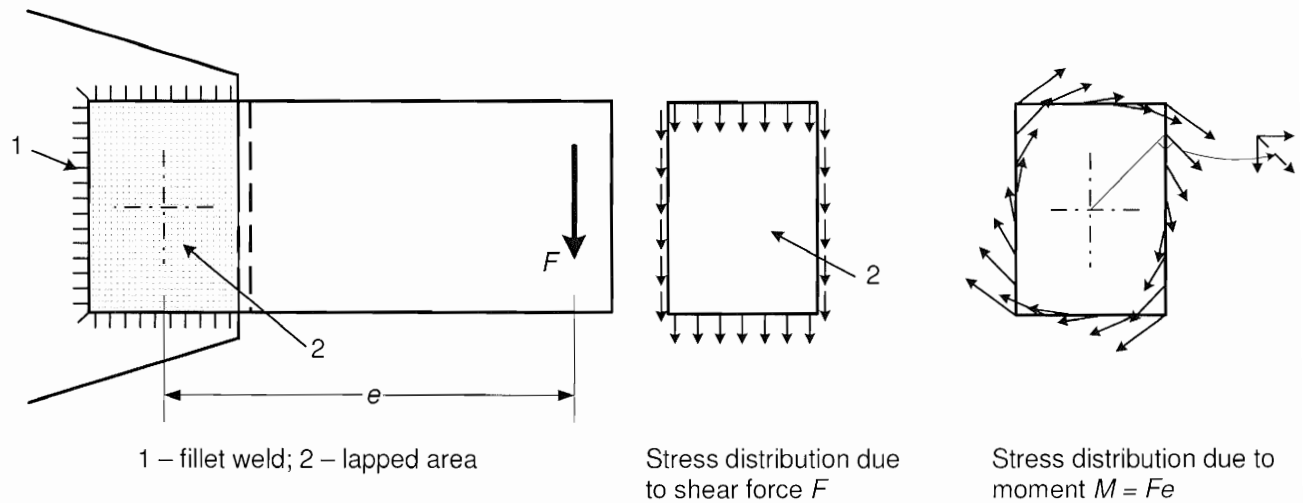

Figure 5.4 —Stresses in lapped joints

5.5 Adhesive bonds

(1) Fatigue assessment should include failure surface through the bond plane.

NOTE See Annex E.

5.6 Castings

(1) The principal geometric stress should be used. Finite stress analysis or strain gauging in the case of complex shapes may be required, if standard solutions are not available.

5.7 Stress spectra

(1) The methods for cycle counting of stress ranges for the purpose of deriving stress spectra are given in Annex A.

5.8 Calculation of equivalent stress range for standardised fatigue load models

5.8.1 General

(1) The fatigue assessment for standardized fatigue loads as specified in EN 1991 should be carried out according to one of the following approaches:

- Nominal stress ranges for constructional details shown in the detail category information;
- modified nominal stress ranges where abrupt changes of section occur close to the initiation site which are not included in the constructional detail information;
- geometric stress ranges where high stress gradients occur close to a weld toe.

NOTE The National Annex may give information on the use of the nominal stress ranges or modified nominal stress ranges.

A1 (2) The design value of stress range to be used for the fatigue assessment should be the stress ranges $\gamma_{ff} \Delta\sigma_{E,2e}$ corresponding to $N_C = 2 \times 10^6$ cycles. **A1**

5.8.2 Design value of stress range

A1 (1) The design value of nominal stress ranges $\gamma_{Ff} \Delta\sigma_{E,2e}$ should be determined as follows:

$$\gamma_{Ff} \Delta\sigma_{E,2e} = \lambda_1 \times \lambda_2 \times \dots \times \lambda_i \times \dots \times \lambda_n \times \Delta\sigma(\gamma_{Ff} Q_k) \quad \text{for nominal stress} \quad (5.1)$$

$$\gamma_{Ff} \Delta\sigma_{E,2e}^* = K_{gt} \gamma_{Ff} \Delta\sigma_{E,2e} \quad \text{for modified nominal stress} \quad (5.2)$$

where

$\Delta\sigma(\gamma_{Ff} Q_k)$ is the stress range caused by the fatigue loads specified in EN 1991;

λ_i are damage equivalent factors depending on the load situation and the structural characteristics as well as other factors;

K_{gt} is the stress concentration factor to take account of the local stress magnification in relation to detail geometry not included in the reference $\Delta\sigma_C$ - N -curve, see 5.3.2.1.

NOTE 1 The values of λ_i may be given in the national annex.

NOTE 2 λ_i -values for steel components may not be applicable for aluminium components. **A1**

6 Fatigue resistance and detail categories

6.1 Detail categories

6.1.1 General

(1) The verification of adequate fatigue resistance is based on the resistance values of a number of standardised detail categories. A detail category may comprise one or more frequently used and classified constructional details. The detail categories should be defined by their reference fatigue strength and the corresponding value for the inverse slope of the main part of the linearised $\Delta\sigma$ - N relationship, and should comply with the provisions in 6.2.

6.1.2 Factors affecting detail category

(1) The fatigue strength of a constructional detail should take into account the following factors:

- a) The direction of the fluctuating stress relative to the constructional detail;
- b) the location of the initiating crack in the constructional detail;
- c) the geometrical arrangement and relative proportion of the constructional detail.

(2) The fatigue strength depends on the following:

- a) The product form;
- b) the material (unless welded);
- c) the method of execution;
- d) the quality level (in the case of welds and castings);
- e) the type of connection.

6.1.3 Constructional details

(1) Constructional details may be divided into the following three main groups:

- a) Plain-members, welded members and bolted joints;
- b) adhesively bonded joints;
- c) castings.

NOTE 1 One set of detail categories and constructional details with $\Delta\sigma$ - N relationships for fatigue resistance of group a) members subject to ambient temperatures and which do not require surface protection (see Table 6.2) are given in Annex J. The National Annex may specify another set of detail categories and constructional details together with a set of consistence criteria for such members, taking the provisions in 6.1.2 and 6.3 into account. The set of categories given in Annex J is recommended.

NOTE 2 The National Annex may specify constructional details which are not covered by Annex J.

NOTE 3 For guidance on castings, see Annex I.

NOTE 4 For guidance on adhesively bonded joints, see Annex E.

6.2 Fatigue strength data

6.2.1 Classified constructional details

(1) The generalised form of the $\Delta\sigma$ - N relationship is shown in Figure 6.1, plotted on logarithmic scales. The fatigue strength curve is represented by the mean line minus 2 standard deviation from the experimental data.

(2) The fatigue design relationship for endurance in the range between 10^5 to 5×10^6 cycles is defined by the equation:

$$N_i = 2 \times 10^6 \left(\frac{\Delta\sigma_c}{\Delta\sigma_i \gamma_{Ff} \gamma_{Mf}} \right)^{m_1} \quad (6.1)$$

where:

N_i is the predicted number of cycles to failure of a stress range $\Delta\sigma_i$

$\Delta\sigma_c$ is the reference value of fatigue strength at 2×10^6 cycles, depending on the detail category, where standardized values are given in Table 6.1

$\Delta\sigma_i$ is the constant stress range for the principal stresses in the construction detail for n_i cycles

m_1 is the inverse slope of the $\log\Delta\sigma$ - $\log N$ fatigue strength curve, depending on the construction detail category

γ_{Ff} is the partial factor allowing for uncertainties in the loading spectrum and analysis of the response

γ_{Mf} is the partial factor for uncertainties in materials and execution.

NOTE 1 For values of γ_{Ff} , see 2.4.

NOTE 2 The value of the partial factor γ_{Mf} for a specific construction detail type may be defined in the national annex. Recommended values are given in L.4 for use when Annex J resistance data is adopted.

NOTE 3 For the value of the partial factor γ_{Mf} for adhesively bonded joints see Annex E.

Table 6.1 — Standardized $\Delta\sigma_c$ values (N/mm²)

140, 125, 112, 100, 90, 80, 71, 63, 56, 50, 45, 40, 36, 32, 28, 25, 23, 20, 18, 16, 14, 12
--

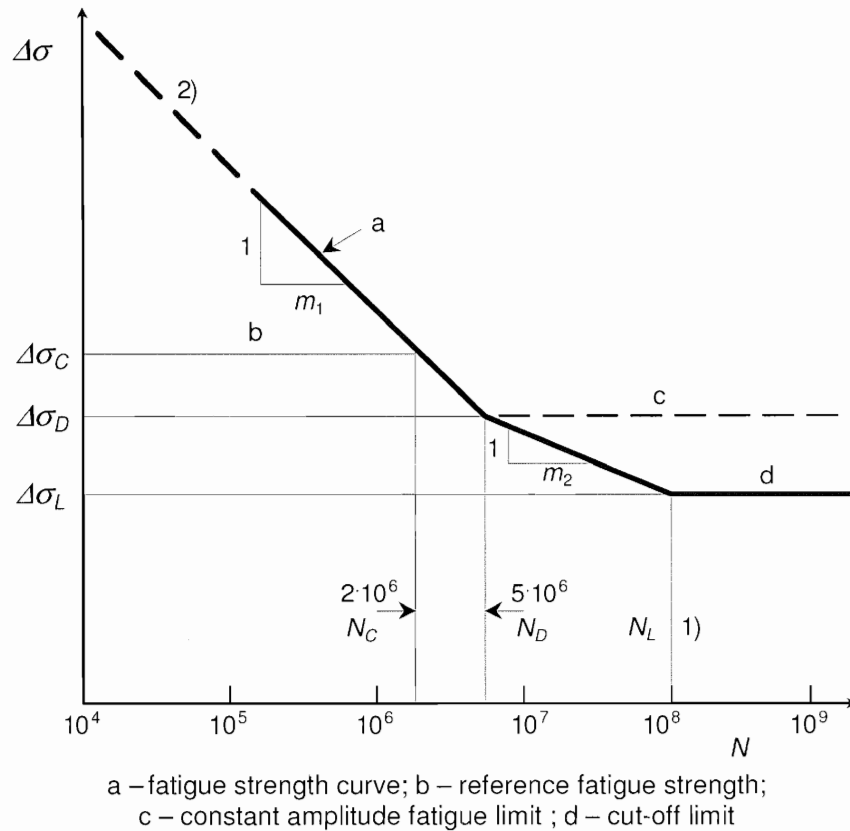

Figure 6.1 —Fatigue strength curve $\log \Delta \sigma$ - $\log N$

(3) For N_L under certain exposure conditions, see 6.4.

(4) The fatigue design relationship for endurances in the range between 5×10^6 to 10^8 cycles is defined by the equation:

$$N_i = 5 \times 10^6 \left(\frac{\Delta \sigma_c}{\Delta \sigma_i} \frac{1}{\gamma_{Ff} \gamma_{Mf}} \right)^{m_2} \left(\frac{2}{5} \right)^{\frac{m_2}{m_1}} \quad (6.2)$$

(5) The constant amplitude fatigue limit, $\Delta \sigma_D$, is defined at 5×10^6 cycles (for plain material assumed at 2×10^6 cycles), below which constant amplitude stress cycles are assumed to be non-damaging. However, even if occasional cycles occur above this level, they will cause propagation which, as the crack extends, will cause lower amplitude cycles to become damaging. For this reason the inverse logarithmic slope of the basic $\Delta \sigma$ - N curves between 5×10^6 and 10^8 cycles should be changed to m_2 for general spectrum action conditions, where $m_2 = m_1 + 2$.

NOTE The use of the inverse slope constant $m_2 = m_1 + 2$ may be conservative for some spectra.

(6) Any stress cycles below the cut-off limit $\Delta \sigma_L$, assumed at 10^8 cycles, should be assumed to be non-damaging.

(7) For stress ranges applied less than 10^5 times the resistance values according to Figure 6.1 may be unnecessary conservative for certain constructional details.

NOTE Annex F gives guidance for the fatigue design for endurances in the range below 10^5 cycles. The National Annex may give additional provisions.

(8) In the range between 10^3 and 10^5 a check should be made that the design stress range does not result in a maximum tensile stress that exceeds other ultimate limit state design resistance values for the constructional detail, see EN 1999-1-1.

(9) For the purpose of defining a finite range of detail categories and to enable a detail category to be increased or decreased by a constant geometric interval, a standard range of $\Delta\sigma_c$ values is given in Table 6.1. An increase (or decrease) of 1 detail category means selecting the next larger (or smaller) $\Delta\sigma_c$ value whilst leaving m_1 and m_2 unchanged. This does not apply to adhesively bonded joints.

(10) The detail categories apply to all values of mean stress, unless otherwise stated.

NOTE For guidance on enhanced fatigue strength values for compressive or low tensile strength values see Annex G.

(11) For flat members under bending stresses where $\Delta\sigma_1$ and $\Delta\sigma_2$ (see Figure 6.2) are of opposite sign the respective fatigue stress value for certain detail types may be increased by one or two detail categories according to Table 6.1 for $t \leq 15\text{mm}$.

NOTE The National Annex may give the detail type and the thickness range for which an increase may be permitted, as well as the number of categories. It is recommended that the increase in number of categories should not exceed 2.

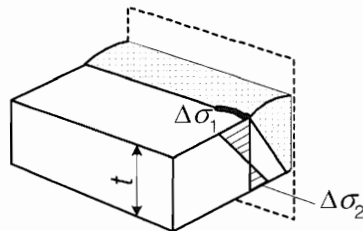

Figure 6.2 – Flat member under bending stresses

6.2.2 Unclassified details

(1) Details not fully covered by a given detail category should be assessed by reference to published data where available. Alternatively fatigue acceptance tests may be carried out.

NOTE Fatigue tests should be carried out in accordance with Annex C.

6.2.3 Adhesively bonded joints

(1) Fatigue strengths of adhesively bonded joints should be based on test data specific to the application, taking the relevant exposure conditions into account.

NOTE For design of adhesively bonded joints see Annex E.

6.2.4 Determination of the reference hot spot strength values

(1) The calculated hot spot stresses are dependent on the hot spot design method applied, and the design values for the reference hot spot strength should be correlated to the design procedure used.

NOTE Annex K contains a hot spot reference detail method. This Annex may be used in combination with Annex J to determine the reference hot spot strength values.

6.3 Effect of mean stress

6.3.1 General

(1) The fatigue strength data given in detail category tables refer to high tensile mean stress conditions. Where the mean stress is compressive or of low tensile value the fatigue life may be enhanced under certain conditions.

NOTE See Annex G for further guidance.

6.3.2 Plain material and mechanically fastened joints

(1) Provided that the effects of tensile residual and lack of fit stresses are added to the applied stresses, a fatigue enhancement factor may be applied.

NOTE See Annex G.

6.3.3 Welded joints

(1) No allowance should be made for mean stress in welded joints except in the following circumstances:

- a) Where tests have been conducted which represent the true final state of stress (including residual and lack of fit stresses) in the type of joint and demonstrate a consistent increase in fatigue strength with decreasing mean stress;
- b) where improvement techniques are to be used which have been proven to result in residual compressive stresses and where the applied stress is not of such a magnitude that the compressive residual stresses will be reduced by yielding in service.

NOTE See Annex G.

6.3.4 Adhesive joints

(1) No allowance should be made for effect of mean stress without justification by tests.

6.3.5 Low endurance range

(1) For certain constructional details higher fatigue strengths may be used for negative R ratios for $N < 10^5$ cycles.

NOTE See Annex G.

6.3.6 Cycle counting for R-ratio calculations

(1) The method of obtaining the maximum, minimum and mean stress for individual cycles in a spectrum using the reservoir counting method should be as stated in Annex A, Figure A.2.

6.4 Effect of exposure conditions

(1) For certain combinations of alloy and exposure conditions, the detail category number given for a constructional detail should be downgraded. The fatigue strength data given in this European Standard should not apply in case of ambient temperature of more than 65°C or more than 30°C in marine environment, unless an efficient corrosion prevention is provided.

NOTE Table 6.2 gives for the detail categories given in Annex G the number of detail categories, by which they should be reduced according to exposure conditions and alloy.

Table 6.2 —Number of detail categories by which $\Delta\sigma_c$ should be reduced according to exposure conditions and alloy

Material			Exposure conditions							
Alloy Series ¹⁾	Basic Composition	Protection ratings (see EN 1999-1-1)	Rural	Industrial Urban		Marine			Immersed	
				Mode-rate	Severe	Non-Industrial	Mode-rate	Severe ²⁾	Fresh Water	Sea Water ²⁾
3xxx	AlMn	A	0	0	(P) ¹⁾	0	0	0	0	0
5xxx	AlMg	A	0	0	(P) ¹⁾	0	0	0	0	0
5xxx	AlMgMn	A	0	0	(P) ¹⁾	0	0	0	0	1
6xxx	AlMgSi	B	0	0	(P) ¹⁾	0	0	1	0	2
7xxx	AlZnMg	C	0	0	(P) ¹⁾	0	0	2	1	3

¹⁾(P) very dependent on exposure conditions. Regularly maintained protection may be required to avoid risk of local exposures which may be particularly detrimental to crack initiation.

²⁾The value of N_b should be increased from 5×10^6 to 10^7 cycles.

NOTE Downgrading is not needed for detail categories < 25 N/mm².

6.5 Improvement techniques

(1) Methods for improving the fatigue strength of certain welded constructional details may be used.

NOTE Improvement techniques are generally expensive to apply and present quality control difficulties. They should not be relied upon for general design purposes, unless fatigue is particularly critical to the overall economy of the structure, in which case specialist advice should be sought. They are more commonly used to overcome existing design deficiencies. See Annex H.

Annex A [normative]: Basis for calculation of fatigue resistance

A.1 General

A.1.1 Influence of fatigue on design

(1) Structures subjected to frequently fluctuating service loads may be susceptible to failure by fatigue and shall be checked for that limit state.

(2) The degree of compliance with the ultimate or serviceability limit state criteria given in EN 1999-1-1 should not be used as a measure of the risk of fatigue failure (see A.1.3).

(3) The extent to which fatigue is likely to govern the design should be established at the conceptual stage of design. To obtain sufficient accuracy in prediction of the safety against fatigue failure it is necessary to:

- a) Make an accurate prediction of the complete service load sequence throughout the design life;
- b) assess the elastic response of the structure under the predicted loads sufficiently accurately;
- c) perform constructional detail design, prescribe methods of manufacturing and degree of quality control appropriately. These issues can have a major influence on fatigue strength, and may need to be controlled more precisely than for structures designed for other limit states. For information on requirements to execution, see EN 1090-3.

A.1.2 Mechanism of failure

(1) It should be assumed that fatigue failure usually initiates at a highly stressed point (due to abrupt geometry change, tensile residual stress or sharp crack-like discontinuities). Fatigue cracks will extend incrementally under the load of cyclic stress change. They normally remain stable under constant load. Failure occurs if the remaining cross section is insufficient to carry the peak applied load.

(2) It should be assumed that fatigue cracks propagate approximately at right angles to the direction of maximum principal stress range. The rate of propagation increases exponentially. For this reason crack growth is often slow in the early stages, and fatigue cracks tend to be inconspicuous for the major part of their life. This may give rise to problems of detection in service.

A.1.3 Potential sites for fatigue cracking

(1) The following initiation sites for fatigue cracks associated with specified constructional details should be considered:

- a) Toes and roots of fusion welds;
- b) machined corners;
- c) punched or drilled holes;
- d) sheared or sawn edges;
- e) surfaces under high contact pressure (fretting);
- f) roots of fastener threads.

(2) Fatigue cracks may also be initiated at unspecified features, which may occur in practice. The following should be considered where relevant:

- a) Material discontinuities or weld flaws;
- b) Notches or scoring from mechanical damage;
- c) Corrosion pits.

A.1.4 Conditions for fatigue susceptibility

(1) In assessing the likelihood of susceptibility to fatigue, the following should be taken into account:

- a) High ratio of dynamic to static loading: Moving or lifting structures, such as land or sea transport vehicles, cranes, etc. are more likely to be prone to fatigue problems than fixed structures, unless the latter are predominantly carrying moving loads, as in the case of bridges;
- b) frequent applications of load: This results in a high number of cycles in the design life. Slender structures or members with low natural frequencies are particularly prone to resonance and hence magnification of dynamic stress, even when the static design stresses are low. Structures subjected predominantly to fluid load, such as wind, and structures supporting machinery should be carefully checked for resonant effects;
- c) use of welding: Some commonly used welded details have low fatigue strength. This applies not only to joints between members, but also to any attachment to a loaded member, whether or not the resulting connection is considered to be 'structural';
- d) complexity of joint detail: Complex joints frequently result in high stress concentrations due to local variations in stiffness of the load path. Whilst these may often have little effect on the ultimate static capacity of the joint they can have a severe effect on fatigue resistance. If fatigue is dominant the member cross-sectional shape should be selected to ensure smoothness and simplicity of joint design, so that stresses can be calculated and adequate standards of fabrication and inspection can be assured;
- e) under certain thermal and chemical exposure conditions the fatigue strength may be reduced if the surface of the metal is unprotected.

A.2 Safe life design

A.2.1 Prerequisites for safe life design

(1) The predicted service history of the structure should be available in terms of a loading sequence and frequency. Alternatively the stress response at all potential initiation sites should be available in terms of stress histories.

(2) The fatigue strength characteristics at all potential initiation sites should be available in terms of fatigue strength curves.

(3) All potential fatigue crack initiation sites which have high stress fluctuations and/or severe stress concentrations should be checked.

(4) The quality standards used in the manufacture of the components containing potential initiation sites should be consistent with the constructional detail being used.

(A1) (5) The basic procedure is as follows (see Figure A.1):

- a) obtain an upper bound estimate of the service load sequence for the structure's design life (see 2.3);
- b) estimate the resulting stress history at the potential crack initiation site being checked (see A.2.3); **(A1)**

- Ⓐ) c) where nominal stresses are being used, modify the stress history in any region of geometrical stress concentration which is not already included in the detail category, by applying an appropriate stress concentration factor (see 5.3.2);
- d) reduce the stress history to an equivalent number of cycles (n_i) of different stress ranges $\Delta\sigma_i$ using a cycle counting technique (see A.2.3);
- e) rank the cycles in descending order of range $\Delta\sigma_i$ to form a stress-range spectrum, where $i = 1, 2, 3$ etc. for the first, second, third band in the spectrum (see A.2.3);
- f) categorise the construction detail in accordance with the given set of detail categories. For the appropriate detail category and the respective $\Delta\sigma-N$ relationship determine for the design stress range ($\Delta\sigma_i$) the permissible endurance (N_i);
- g) calculate the total damage value $D_{L,d}$ caused by all cycles based on linear damage accumulation where

$$D_{L,d} = \sum \frac{n_i}{N_i} \quad (\text{A.1})$$

- h) calculate the safe life T_s , where

$$T_s = \frac{T_L}{D_{L,d}} \quad (\text{A.2})$$

where the design life of T_L has the same units as T_s ;

- i) take one or more of the following actions if T_s is less than T_L :
- redesign the structure or member to reduce the stress levels;
 - change the construction detail to one with a higher category;
 - use a damage tolerant design approach, where appropriate (see A.3). Ⓐ)

A.2.2 Cycle counting

(1) Cycle counting is a procedure for breaking down a complex stress history into a convenient spectrum of cycles in terms of stress range $\Delta\sigma$, number of cycles n and, if necessary, R ratio.

(2) For short stress histories where simple action events are repeated a number of times, the Reservoir method is recommended. It is easy to visualise and simple to use (see Figure A.2). Where long stress histories have to be used, such as those obtained from measured strains in actual structures (see Annex C) the Rain-Flow method is recommended. Both methods are suitable for computer analysis.

A.2.3 Derivation of stress spectrum

(1) The listing of cycles in descending order of stress range $\Delta\sigma$ results in a stress spectrum. For ease of calculation it may be required to simplify a complex spectrum into fewer bands. A conservative method is to group bands together into larger groups containing the same total number of cycles, but whose stress range is equal to that of the highest band in the group. More accurately, the weighted average of all the bands in one group can be calculated using the power m , where m is the inverse slope of the $\Delta\sigma-N$ curve most likely to be used (see Figure A.3). The use of an arithmetic mean value will always be not conservative.

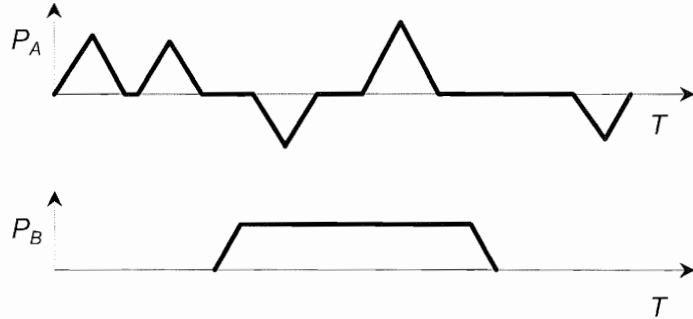
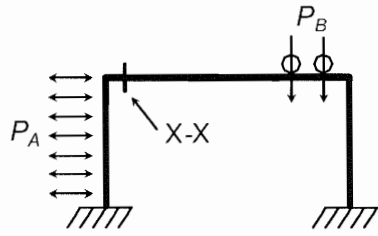

a) System, constructional detail X-X and loading

b) Typical load cycle (repeated n times in design). T = time

c) Stress history at detail X-X



d) Cycle counting, reservoir method

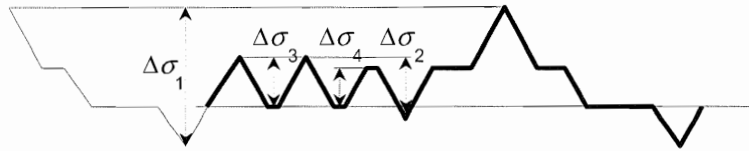

e) Stress range spectrum

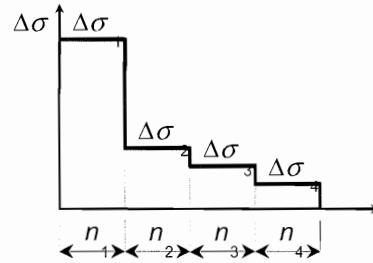

f) N_i = cycles to failure at stress range level $\Delta\sigma_i$,

$\log\Delta\sigma - \log N$ design line for constructional detail X-X

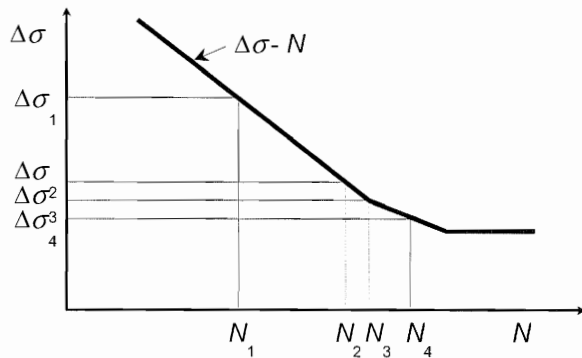

g) Damage summation, Palmgren-Miner-rule

$$\sum \left(\frac{n_i}{N_i} \right) = \frac{n_1}{N_1} + \frac{n_2}{N_2} + \dots + \frac{n_n}{N_n} = D$$

Figure A.1 —Fatigue assessment procedure

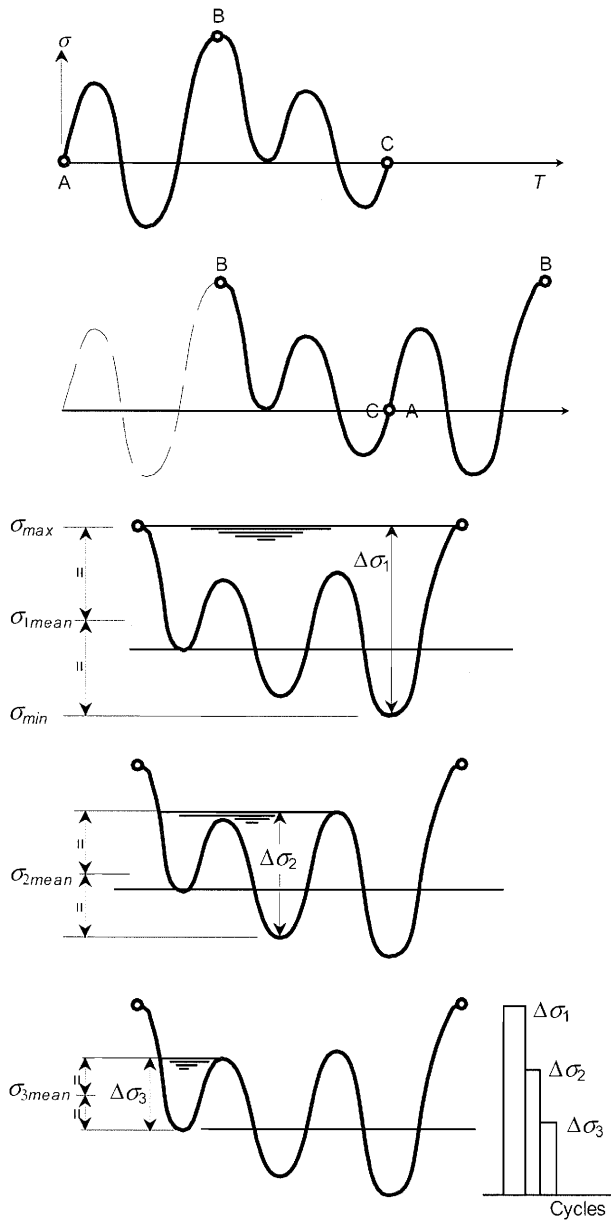

Step 1. Determine stress history for loading event. Identify peak B

Step 2. Move stress history on left of peak B to right

Step 3. Fill "reservoir" with "water". Greatest depth is major cycle

Step 4. Drain at greatest depth. Find new maximum depth. This is second largest cycle

Step 5 Onwards. Repeat until all "water" drained. Sum of all cycles is stress spectrum for above history

Figure A.2 – Reservoir cycle counting method

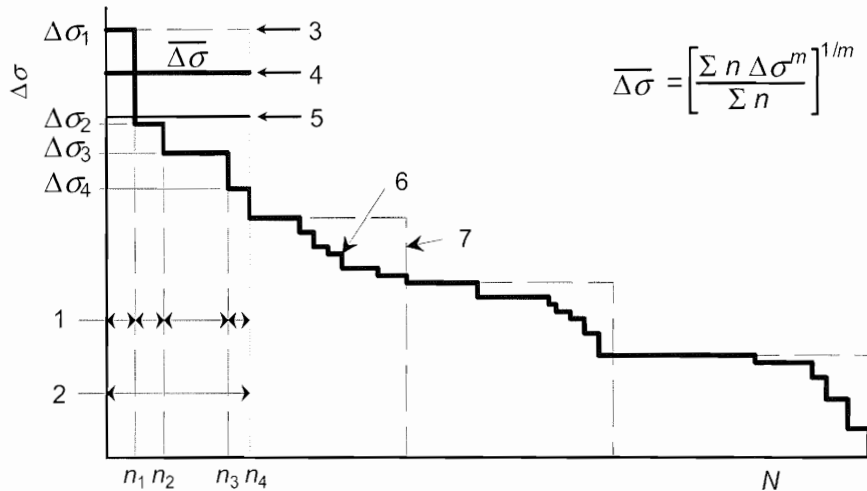

1 – original bands; 2 – simplified band; $\Delta\sigma$ stress range; N cumulative frequency (any cycle number); 3 – peak (conservative); 4 – weighted mean (most accurate); 5 – arithmetic mean (unconservative) 6 – recorded spectrum; 7 – simplified spectrum for design

Figure A.3 – Simplified stress range spectrum

A.3 Damage tolerant design

A.3.1 Prerequisites for damage tolerant design

- (1) Damage tolerant design should only be used where the following conditions apply:
- the fatigue crack initiation sites should be on or close to a surface which should be readily accessible in service;
 - practical inspection methods should be available which are capable of detecting the cracks and measuring their extent well before they have reached their fracture critical size. See 1.7.3;
 - the procedure in A.3.2 should be applied to determine the minimum inspection frequency and maximum permissible crack size before correction becomes necessary;

NOTE An alternative method of determining inspection frequency is given in L.2 and L.3 for use when Annex J resistance data is adopted.

- the maintenance manual should specify the information listed in 1.7.3 for each potential crack location. A_1

A.3.2 Determination of inspection strategy for damage tolerant design

- A_1 (1) At each potential initiation site where the safe life T_s calculated in accordance with Equation (A.2) is less than the design life T_L , the inspection interval T_i should be calculated. A_1

(2) The maintenance manual should specify that the first inspection of each potential initiation site should take place before the safe life has elapsed.

(3) The maintenance manual should specify that subsequent inspections should take place at regular intervals T_i where

$$T_i \leq 0,5 T_f \tag{A.3}$$

Where T_f is the calculated time for a crack, having initiated at the site being assessed, to grow from a detectable surface length l_d to a fracture critical length l_f (see Figure A.4).

NOTE The assumed minimum exposed length of surface crack should take into consideration the accessibility, location, likely surface condition and method of inspection. Unless specific testing is undertaken to demonstrate that shorter lengths can be detected with a probability exceeding 90%, the assumed value of l_d should not be less than the recommended value in Table A.1 where the full crack length is accessible for inspection.

(4) Where any other permanent structural or non-structural part prevents full access to the crack, the obscured length of crack should be added to the appropriate value in Table A.1 to derive the value of l_d for calculation purposes.

(5) Where heavy constructional thickness is used and where the initiation site is on an inaccessible surface, (e.g. the root of a single sided butt weld in a tubular member), it may be appropriate to plan an inspection strategy based on the use of ultrasonic testing to detect and measure cracks before they reach the accessible surface. Such a strategy should not be undertaken without prior testing and evaluation.

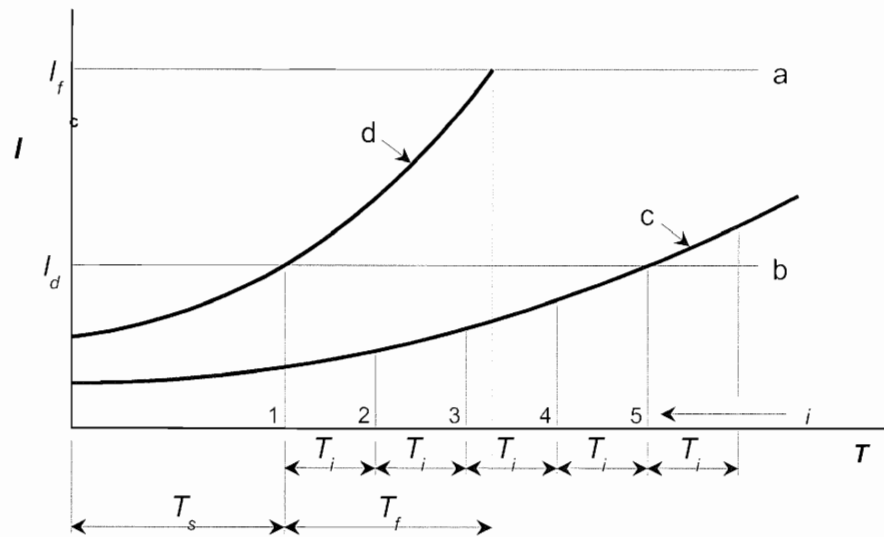

a – fracture critical length; b – assumed minimum detectable length; c – actual growth curve; d – assumed fastest growth curve, see Annex B for upper boundary; i – inspection number; T_i – inspection interval, T_s – time interval to detectable crack length; T_f – time interval for crack growth from detectable crack length to critical crack length

Figure A.4 – Inspection strategy for damage tolerant design

Table A.1 —Recommended safe values of detectable surface crack length l_d in mm.

Method of Inspection	Crack location		
	Plain smooth surface	Rough surface, Weld cap	Sharp corner, Weld toe
Visual, with magnifying aid	20	30	50
Liquid penetrant testing	5	10	15

NOTE The above values assume close access, good lighting and removal of surface coatings.

(6) The value of l_f should be such that the net section, taking into account the likely shape of the crack profile through the thickness, should be able to sustain the maximum static tensile forces under the factored load, calculated in accordance with EN 1999-1-1, without unstable crack propagation.

(7) T_f should be estimated by means of calculation and/or by test, assuming factored load (see 2.4), as follows:

- a) The calculation method should be based on fracture mechanics principles (see Annex B). An upper bound, defined as mean plus two standard deviations, crack growth relationship should be used. Alternatively specific crack growth data may be obtained from standard test specimens using the same material as in the crack propagation path. In which case the crack growth rate should be factored in accordance with the fatigue test factor F (see Table C.1);
- b) where crack growth is obtained from structural or component tests simulating the correct materials, geometry and method of manufacture the relevant applied force pattern should be applied to the test specimen (see Annex C);
- c) the crack growth rates recorded between the crack lengths l_d and l_f should be factored by the fatigue test factor F (see Table C.1).

(8) The maintenance manual should specify the actions to be taken in the event of discovery of a fatigue crack during a regular maintenance inspection, as follows:

- a) If the measured crack length is less than l_d no remedial action need be taken;
- b) if the measured crack length is equal to or exceeds l_d the component should be assessed on a fitness-for-purpose basis with a view to determining how long the structure may safely be allowed to operate without rectification or replacement. In the event of continuation of operation consideration should be given to increasing the frequency of inspection at the location in question;
- c) if the measured crack length exceeds l_f the structure should be immediately taken out of service.

A1 (9) Further guidance is given in Annex L for use when Annex J resistance data is adopted. **A1**

Annex B [informative]: Guidance on assessment of crack growth by fracture mechanics

B.1 Scope

(1) The objective of this annex is to provide information on the use of fracture mechanics for assessing the growth of fatigue cracks from sharp planar discontinuities. Main uses are in the assessment of:

- Known flaws (including fatigue cracks found in service);
- assumed flaws (including consideration of the original joint or NDT detection limits);
- tolerance to flaws (including fitness for purpose assessment of fabrication flaws for particular service requirements).

(2) The method covers fatigue crack growth normal to the direction of principal tensile stress (Mode 1).

B.2 Principles

B.2.1 Flaw dimensions

(1) Fatigue propagation is assumed to start from a pre-existing planar flaw with a sharp crack front orientated normal to the direction of principle tensile stress range $\Delta\sigma$ at that point.

(2) The dimensions of the pre-existing flaws are shown in Figure B.1 depending on whether they are surface breaking or fully embedded within the material.

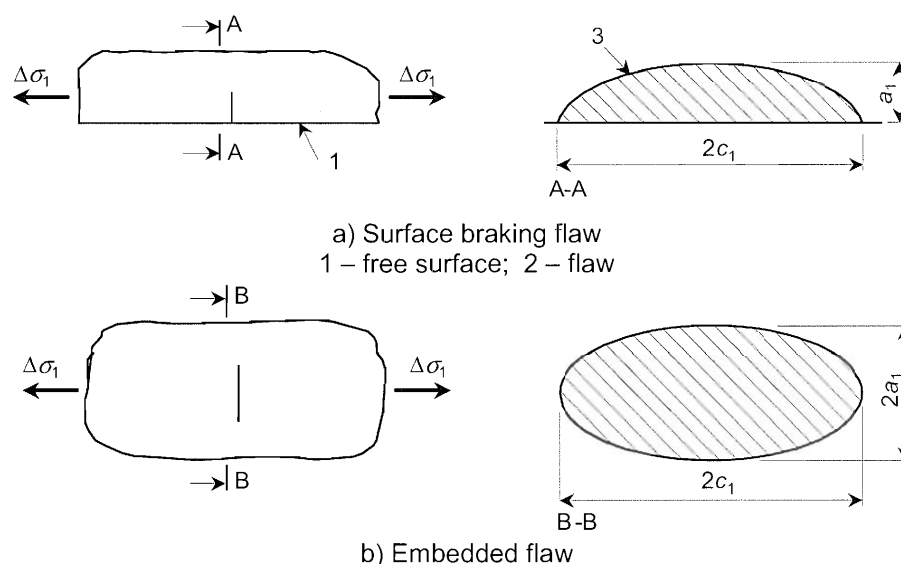

Figure B.1 —Pre-existing planar flaw

B.2.2 Crack growth relationship

(1) Under the action of cyclic stress range $\Delta\sigma$ the crack front will move into the material according to the crack propagation law. In the direction of 'a' the rate of propagation is given by:

$$\frac{da}{dN} = A(\Delta\sigma a^{0.5} y)^m \quad (\text{B.1})$$

where:

- A is the fatigue crack growth rate (FCGR) material constant
- m is the crack growth rate exponent
- y is the crack geometry factor depending on the crack shape, orientation and surface boundary dimensions.

NOTE The units for stress intensity factors ΔK are $\text{Nmm}^{-2} \text{m}^{0.5}$ [$\text{MPa m}^{0.5}$] and for crack growth rate da/dN is [m/cycle]. Data given in B.3 are only valid for these units.

(2) This can be rewritten in the form

$$\frac{da}{dN} = A\Delta K^m \quad (\text{B.2})$$

where ΔK is the stress intensity range and equals $\Delta\sigma a^{0.5} y$.

(3) After the application of N cycles of stress range $\Delta\sigma$ the crack will grow from dimension a_1 to dimension a_2 according to the following integration:

$$N = \int_{a_1}^{a_2} \frac{da}{A\Delta K^m} \quad (\text{B.3})$$

(4) For the general case A , ΔK and m are dependent on a .

B.3 Crack growth data A and m

(1) A and m are obtained from crack growth measurements on standard notched specimens orientated in the LT, TL or ST direction (e.g. see Figure B.2) using standardised test methods. The specimen design should be one for which an accurate stress intensity factor (K) solution (i.e. the relationship between applied action and crack size 'a') is available.

NOTE For further information on standardised test methods see Bibliography B.1.

B.4 Geometry function y

(1) The geometry function y is dependent on the crack geometry (shape and size), the boundary dimensions of the surface of the surrounding material and the stress pattern in the region of the crack path.

(2) This information can be obtained from finite element analyses of the constructional detail using crack tip elements. The stress intensity for different crack lengths is calculated using the J integral procedure. Alternatively it can be calculated from the displacement or stress field around the crack tip, or the total elastic deformation energy.

(3) Published solutions for commonly used geometries (plain material and welded joints) are an alternative source of y values. Standard data are often given in terms of Y where $Y = y\pi^{-0.5}$. A typical example for a surface breaking crack in a plain plate is shown in Figure B.7(a). If the crack is located at a weld toe on the plate surface then a further adjustment for the local stress concentration effect can be made using the magnification factor M_K (see Figure B.7(b)).

NOTE For further information on published y solutions see Bibliography B.1 and B.5.

(4) The product of Y for the plain plate and M_K for the weld toe gives the variation of y as the crack grows through the thickness of the material (see Figure B.7(c)).

B.5 Integration of crack growth

(1) For the general case of a variable amplitude stress history, a stress spectrum has to be derived (see 2.2.1). In practice the complete spectrum should be applied in at least 10 identical sequences with the same stress ranges and R ratios, but with one tenth of the number of cycles. The block with the greatest stress range should be applied first in each sequence (see Figure A.3). The incremental crack growth is calculated using the crack growth polygon for the appropriate R -ratio, for each block of constant amplitude stress cycles.

(2) In the region of welds, unless the residual stress pattern is actually known, either a high R -ratio ($R = 0,8$) or a K_{max} constant crack growth curve should be used.

(3) The crack length 'a' is integrated on this basis until the maximum required crack size a_2 is reached and the numbers calculated.

B.6 Assessment of maximum crack size a_2

(1) This will usually be determined on the basis of net section ductile tearing under the maximum applied tensile action with the appropriate partial factor, see EN 1999-1-1.

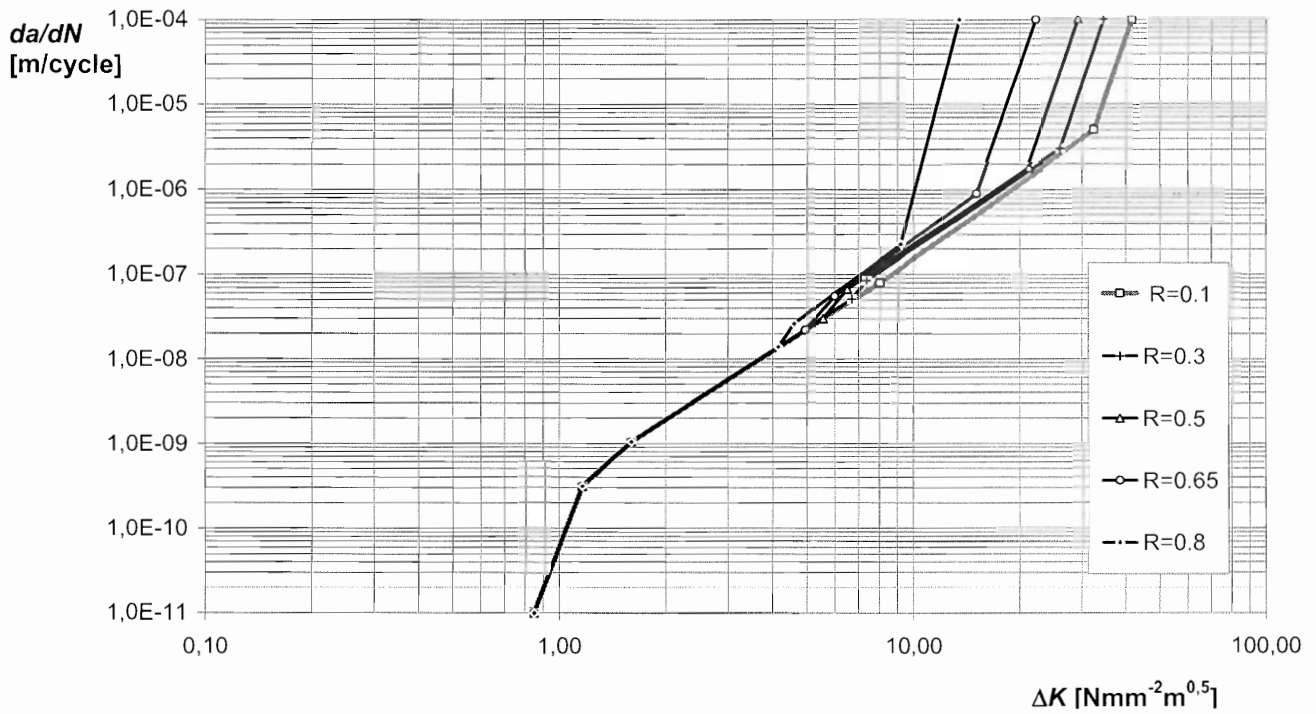
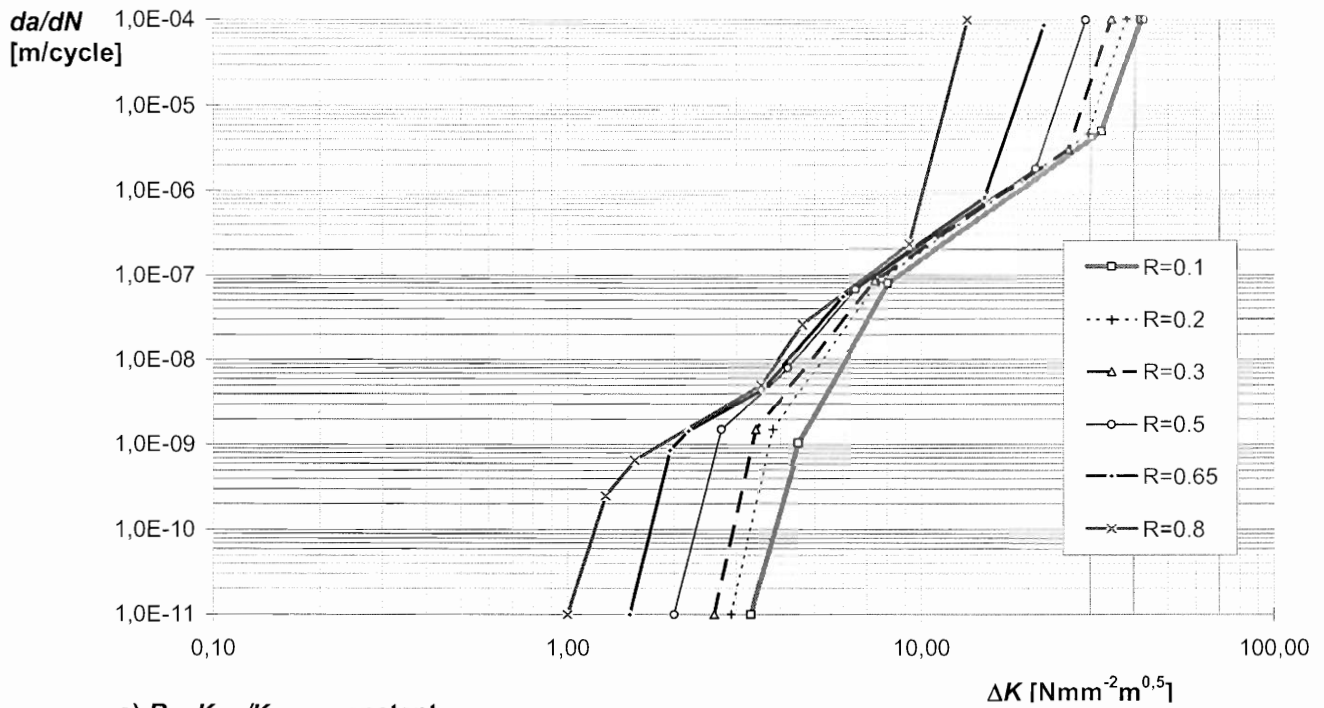

Figure B.3 – Typical fatigue crack growth curves for aluminium alloy EN AW-6005A T6 LT

Table B.1(a) — Fatigue crack growth rate data for EN AW-6005A T6 LT, $R = K_{min}/K_{max} = \text{constant}$

R-ratio	Stress Intensity ΔK [Nmm ⁻² m ^{0.5}]	m	A	R-ratio	Stress Intensity ΔK [Nmm ⁻² m ^{0.5}]	m	A
0,100	3,30	15,00	1,65789E-19	0,500	2,00	16,29	1,24322E-16
	4,50	7,52	1,29310E-14		2,72	3,85	3,17444E-11
	8,00	2,96	1,67380E-10		4,20	4,87	7,41477E-12
	32,4	12,0	4,10031E-24		6,50	2,81	3,50674E-10
	41,61	12,0	4,10031E-24		21,00	12,23	1,21158E-22
	60,00	12,0	4,10031E-24		29,17	12,23	1,21158E-22
0,200	2,90	18,53	2,67965E-20	0,650	1,50	16,93	1,04285E-14
	3,80	5,87	5,94979E-13		1,95	4,43	4,41861E-11
	7,50	2,93	2,22754E-10		2,20	2,39	2,20681E-10
	29,60	12,43	2,25338E-24		3,55	4,77	1,06838E-11
	37,98	12,43	2,25338E-24		6,00	3,05	2,32639E-10
	55,00	12,43	2,25338E-24		15,00	12,00	6,08450E-21
0,300	2,60	18,67	1,77471E-19	0,800	1,00	13,03	9,99999E-12
	3,40	5,24	2,47080E-12		1,28	4,99	7,28970E-11
	7,35	2,82	3,06087E-10		1,55	2,50	2,16851E-11
	26,00	12,40	8,41151E-24		3,50	6,03	2,61124E-12
	34,49	12,40	8,41151E-24		4,60	3,12	2,22506E-10
	50,00	12,40	8,41151E-24		9,20	15,93	9,83032E-23
				13,48	15,93	9,83032E-23	

Table B.1(b) – Fatigue crack growth rate data for EN AW-6005A-T6 LT, $K_{max} = 10 \text{ Nmm}^{-2}\text{m}^{0.5} = \text{constant}$

R-ratio	Stress Intensity ΔK [Nmm ⁻² m ^{0.5}]	m	A	R-ratio	Stress Intensity ΔK [Nmm ⁻² m ^{0.5}]	M	A
0,100	0,85	11,09	6,06810E-11	0,500	0,85	11,09	6,06910E-11
	1,16	3,74	1,80712E-10		1,16	3,74	1,80712E-10
	1,60	2,69	2,96984E-10		1,60	2,70	2,95817E-10
	8,00	2,96	1,67380E-10		5,55	5,09	4,92250E-12
	32,40	12,0	4,10322E-24		6,50	2,81	3,50674E-10
	41,61	12,0	4,10322E-24		21,00	12,20	1,20951E-22
0,300	0,85	11,09	6,06910E-11	0,650	0,85	11,09	6,06910E-11
	1,16	3,74	1,80712E-10		1,16	3,74	1,80712E-10
	1,60	2,71	2,93585E-10		1,60	2,69	2,96037E-10
	6,70	5,52	1,41317E-12		4,95	4,76	1,08127E-11
	7,35	2,82	3,06087E-10		6,00	3,05	2,32639E-10
	26,00	12,40	8,42100E-24		15,00	12,04	6,08100E-21
	34,49	12,40	8,42100E-24		22,18	12,04	6,08100E-21
	0,800	0,85				0,800	0,85
1,16				1,16	3,74		1,80712E-10
1,60				1,60	2,72		2,92718E-10
4,15				4,15	6,01		2,68983E-10
4,60				4,60	3,12		2,22506E-10
9,20				9,20	15,93		9,81913E-23
				13,48	15,93	9,81913E-23	

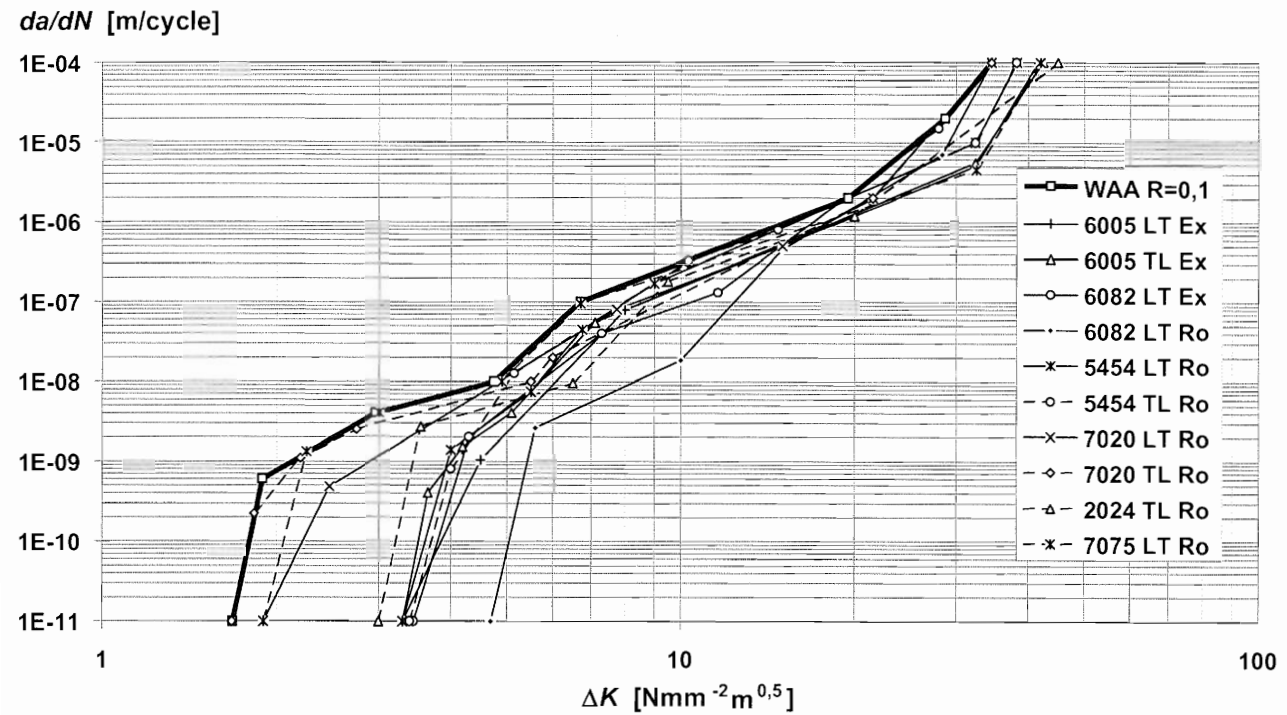

a) $R = 0,1$

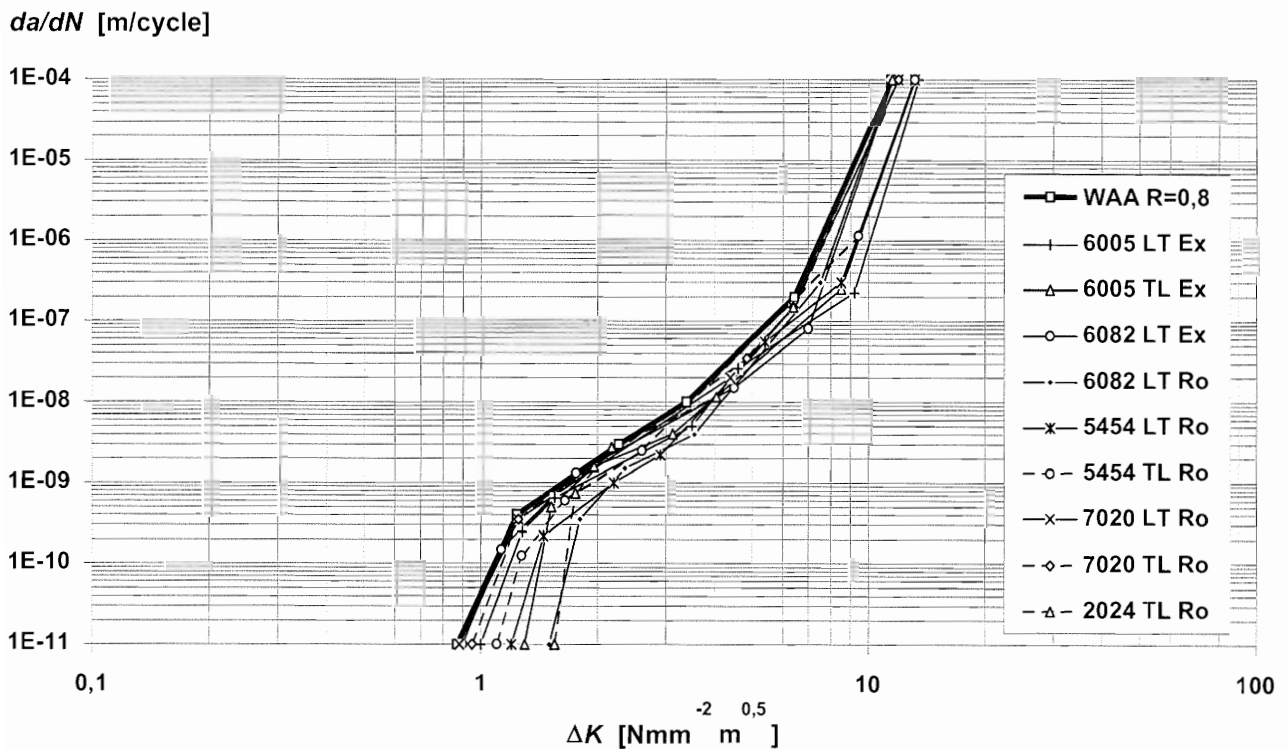

b) $R = 0,8$

Figure B.4 – Typical fatigue crack growth rate curves for various wrought alloys

NOTE The alloys 2024 TL Ro and 7075 LT Ro are not recommended for buildings and civil engineering works. They are given here for comparative reasons.

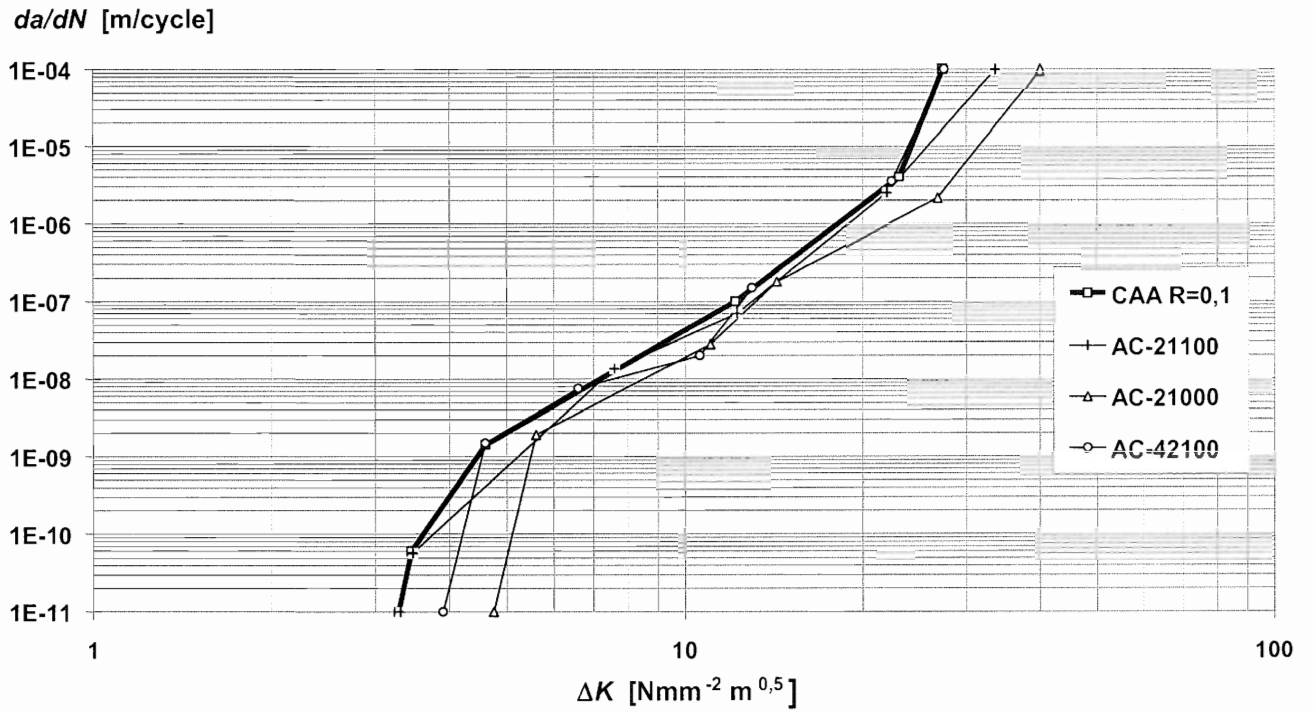

a) $R = 0,1$

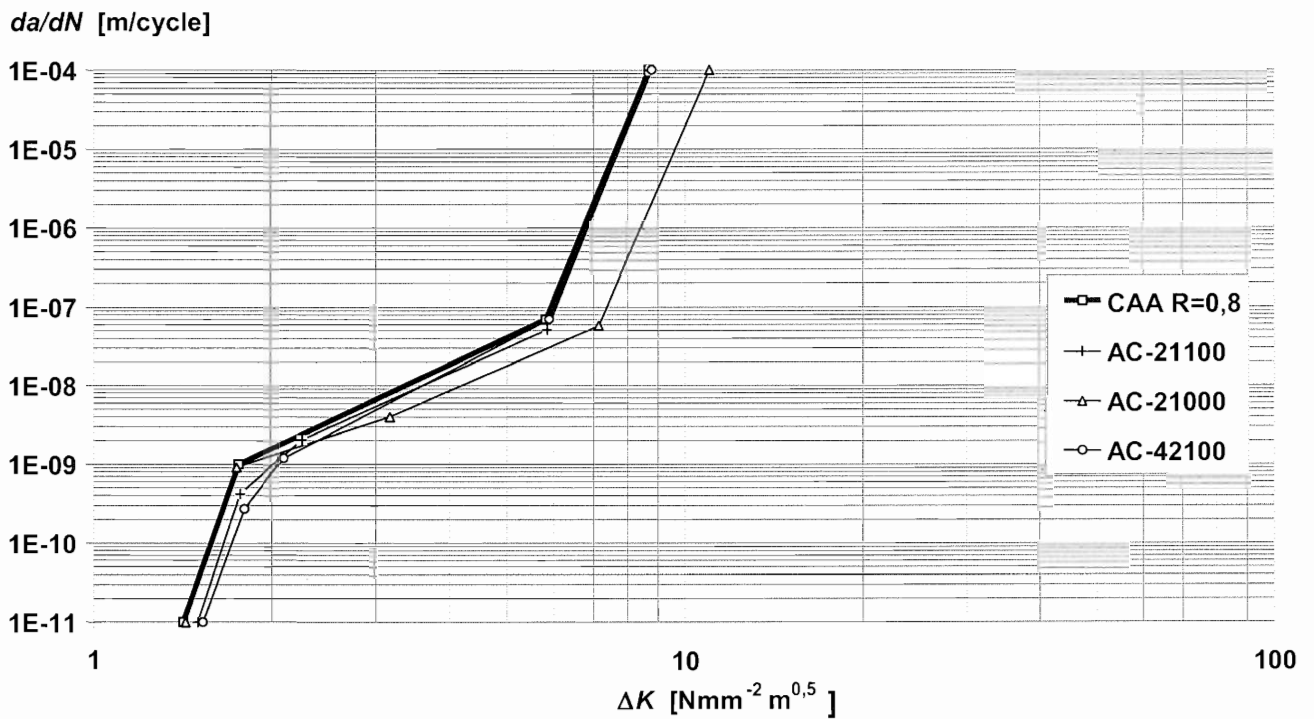

b) $R = 0,8$

Figure B.5 – Typical fatigue crack growth curves for various cast alloys

NOTE The alloys AC-21100 and AC-211000 are not recommended for buildings and civil engineering works. They are given here for comparative reasons.

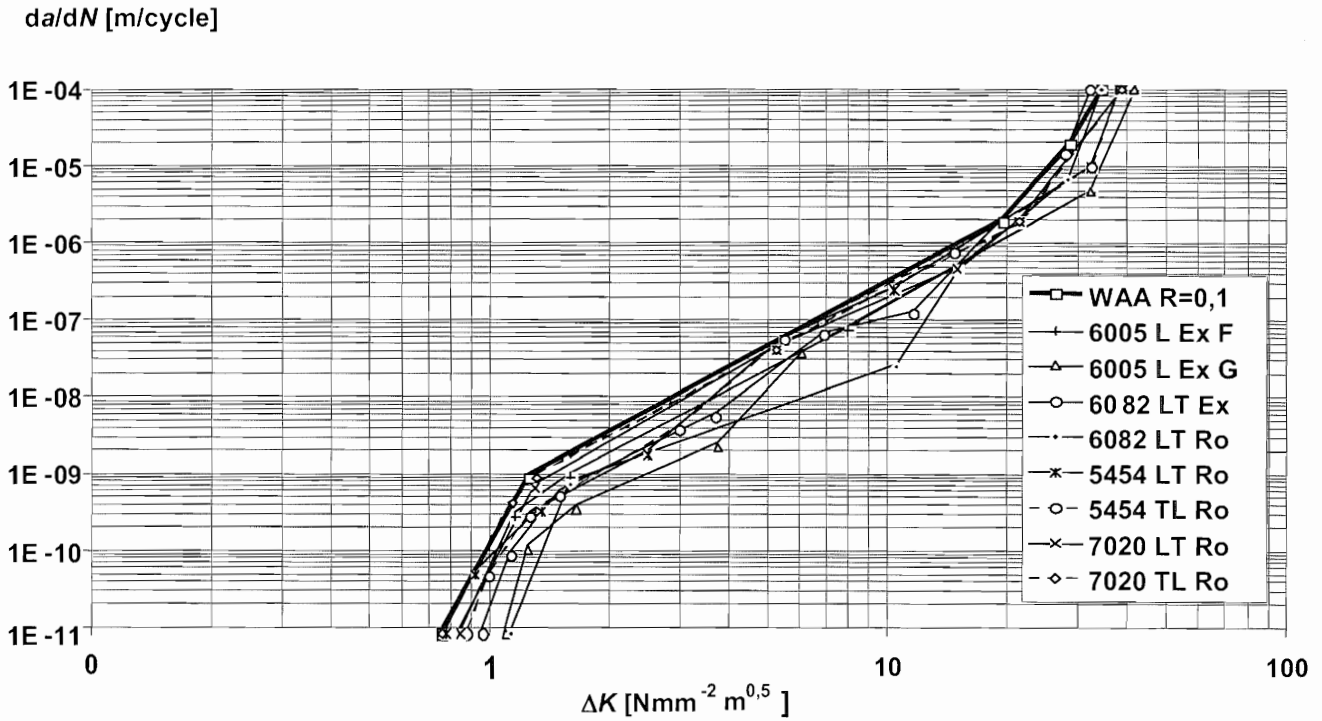

a) $R = 0,1$; $K_{max} = 10 \text{ Nmm}^{-2} \text{ m}^{0,5}$

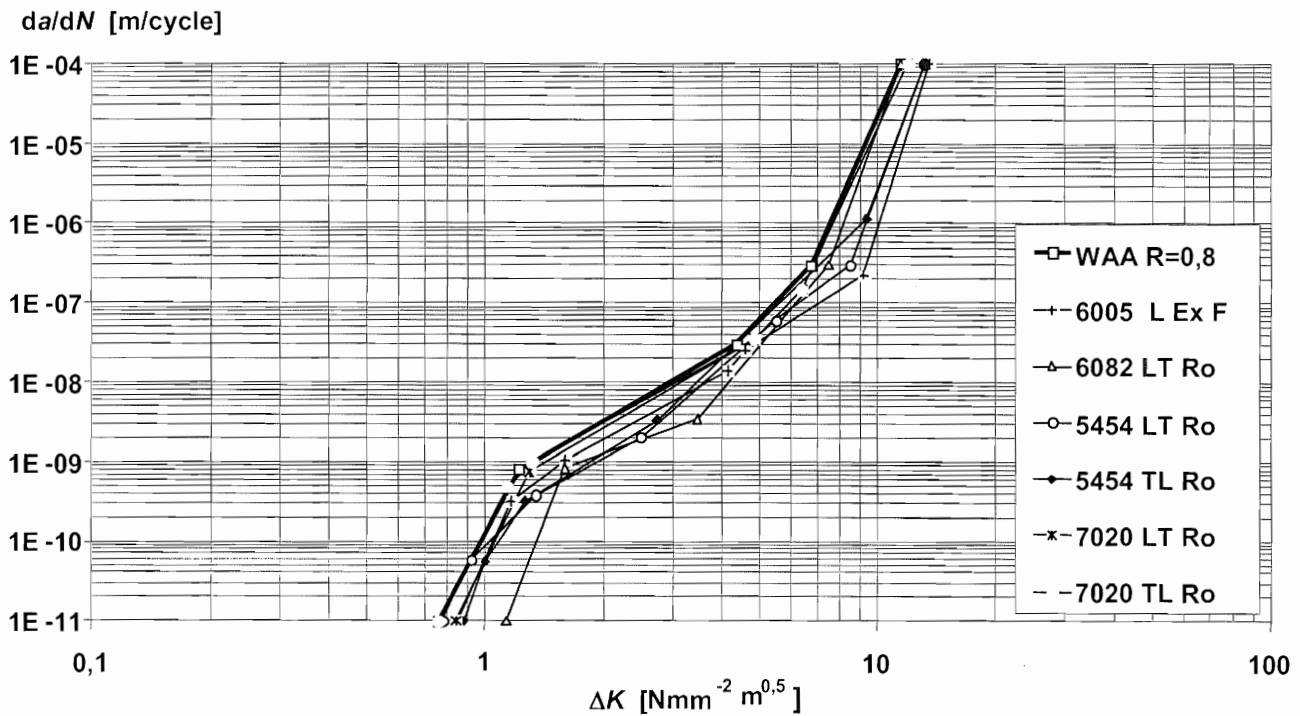

b) $R = 0,8$; $K_{max} = 10 \text{ Nmm}^{-2} \text{ m}^{0,5}$

Figure B.6 – Typical fatigue crack growth curves for various wrought alloys

Table B.2 – Fatigue crack growth rate data for wrought alloys, $R = K_{\min}/K_{\max} = \text{constant}$

R-ratio	Stress Intensity ΔK [Nmm ⁻² m ^{0,5}]	m	A
a) 0,100	1,68	34,8	1,47182E-19
	1,89	4,23	4,06474E-11
	2,96	1,94	4,88644E-10
	4,75	6,69	2,95135E-13
	6,70	2,80	4,82538E-10
	19,51	5,96	4,12350E-14
	28,70	8,74	3,57541E-18
b) 0,800	34,50	8,74	3,57541E-18
	0,87	10,43	4,27579E-11
	1,24	3,33	1,95935E-10
	2,27	2,98	2,60324E-10
	3,40	4,69	3,24644E-11
	6,44	10,8	3,73040E-16
	11,45	10,8	3,73040E-16

NOTE These values are upper bound envelopes derived from curves in Figure B.4(a) and (b).

Table B.3 — Fatigue crack growth rate cast alloys $R = K_{\min}/K_{\max} = \text{constant}$

R-ratio	Stress Intensity ΔK [Nmm ⁻² m ^{0,5}]	m	A
a) 0,100	3,28	35,46	5,10219E-30
	3,45	11,01	7,18429E-17
	4,60	4,37	1,82159E-12
	12,18	5,78	5,37156E-14
	23,07	19,12	3,47503E-32
	27,30	19,12	3,47503E-32
b) 0,800	1,42	21,24	6,08486E-15
	1,76	3,55	1,34235E-10
	5,82	18,1	1,05480E-21
	8,70	18,1	1,05480E-21

NOTE Values are upper bound envelopes derived from curves in Figure B.5(a) and (b).

Table B.4 – Fatigue crack growth rate data for wrought alloys, $K_{max}=10 \text{ Nmm}^{-2}m^{0,5} = \text{constant}$

<i>R</i> -ratio	Stress Intensity ΔK [$\text{Nmm}^{-2}m^{0,5}$]	<i>m</i>	<i>A</i>
0,100	0,76	9,13	1,21148E-10
	1,26	2,77	5,26618E-10
	19,50	5,95	4,18975E-14
	28,71	8,79	3,07173E-18
	34,48	8,79	3,07173E-18
0,800	0,76	9,27	1,27475E-10
	1,22	2,84	4,56026E-10
	4,37	5,28	1,24266E-11
	6,76	11,02	2,12818E-16
	11,45	11,02	2,12818E-16

NOTE Values are upper bound envelopes derived from curves in Figure B.6(a) and (b).

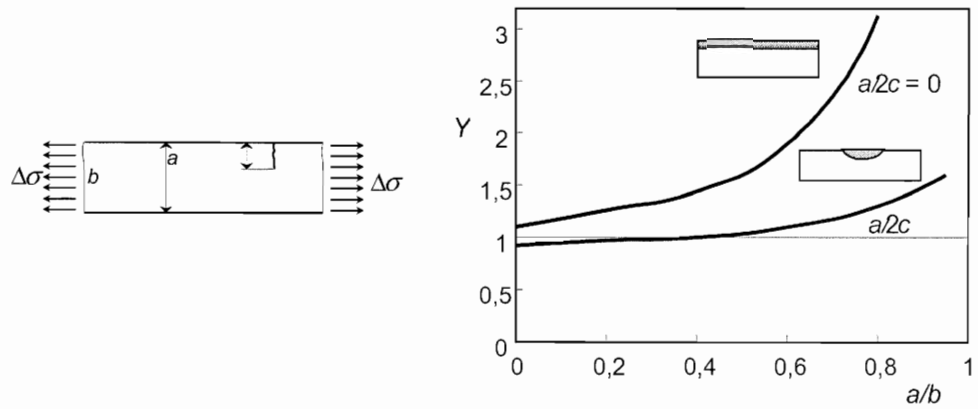

a) Y value for plain plate; a/b = crack depth ratio

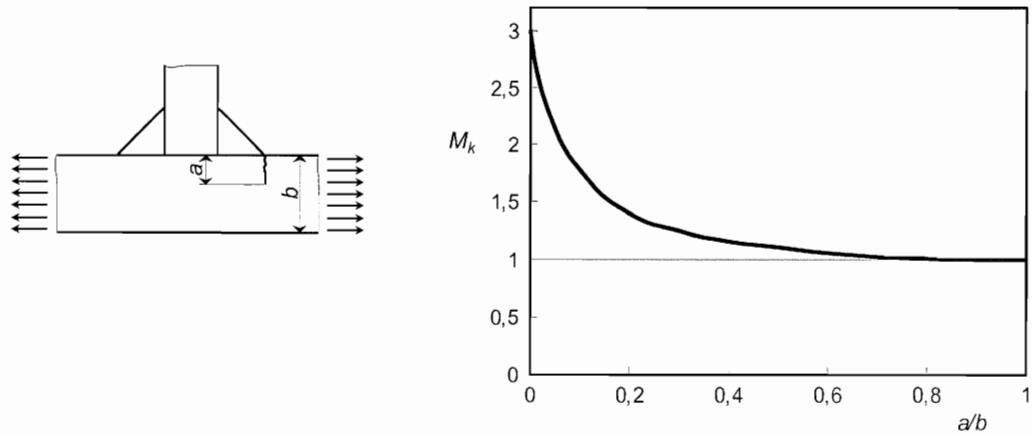

b) M_k value for weld toe stress concentration

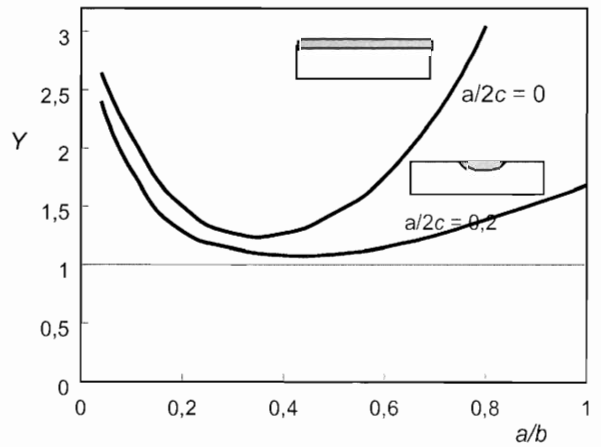

c) Y values for welded joint

Figure B.7 – Use of typical standard geometry solutions for Y and M_k

Annex C [informative]: Testing for fatigue design

C.1 General

(1) Where there are insufficient data for complete verification of a structure by calculations in accordance with 2.2.1 or 2.2.2, supplementary evidence should be provided by a specific testing programme. In this case test data may be required for one or more of the following reasons:

- a) The applied load history or spectrum, for either single or multiple loads, is not available and is beyond practical methods of structural calculations (see 2.3.1 and 2.3.2). This may apply particularly to moving, hydraulically or aerodynamically loaded structures where dynamic or resonance effects can occur;
- b) the geometry of the structure is so complex that estimates of member forces or local stress fields can not be obtained by practical methods of calculations (see 5.2 and 5.4);
- c) the materials, dimensional details, or methods of manufacture of members or joints are different from those given in detail category tables;
- d) crack growth data are needed for damage tolerant design verification.

(2) Testing may be carried out on complete prototypes, on structures equal to the one to be built or on component parts thereof. The type of information being derived from the test should take into account the degree to which the loading, materials, constructional details and methods of manufacture of the test structure or components thereof reflect the structure to be built.

(3) Test data should only be used in lieu of standard data if it is obtained and applied using controlled procedures.

C.2 Derivation of action loading data

C.2.1 Fixed structures subject to mechanical action

(1) This includes structures such as bridges, crane girders and machinery supports. Existing similar structures subject to the same loading sources may be used to obtain the amplitude, phasing and frequency of the applied loads.

(2) Strain, deflection or acceleration transducers fixed to selected components which have been calibrated under known applied loads can record the force pattern over a typical working period of the structure, using analog or digital data acquisition equipment. The components should be selected in such a way that the main load components can be independently deduced using the influence coefficients obtained from the calibration loads.

(3) Alternatively load cells can be mounted at the interfaces between the applied load and the structure and a continuous record obtained using the same equipment.

(4) The mass, stiffness and logarithmic decrement of the test structure should be within 30% of that in the final design and the natural frequency of the modes giving rise to the greatest strain fluctuations should be within 10%. If this is not the case the loading response should be subsequently verified on a structure made to the final design.

(5) The frequency component of the load spectrum obtained from the working period should be multiplied by the ratio of the design life to the working period to obtain the final design spectrum. Allowance for growth in intensity or frequency, or statistical extrapolation from measured period to design life should also be made as required.

C.2.2 Fixed structures subject to actions due to exposure conditions

(1) This includes structures such as masts, chimneys, and offshore topside structures. The methods of derivation of the loading spectrum are basically the same as in C.2.1 except that the working period will generally need to be longer due to the need to obtain a representative spectrum of exposure condition loads such as wind and wave actions. The fatigue damage tends to be confined to a specific band in the overall loading spectrum due to effects of fluid flow induced resonance. This tends to be very specific to direction, frequency and damping. For this reason greater precision is needed in simulating both the structural properties (mass, stiffness and damping) and aerodynamic properties (cross-sectional geometry).

(2) It is recommended that the loading is subsequently verified on a structure to the final design if the original loading data are obtained from structures with a natural frequency or damping differing by more than 10%, or if the cross-sectional shape is not identical.

(3) A final design spectrum can be obtained in terms of direction, intensity and frequency of loading, suitably modified by comparing the loading data during the data collection period with the meteorological records obtained over a typical design life of the structure.

C.2.3 Moving structures

(1) This includes structures such as travelling cranes and other structures on wheels, vehicles and floating structures. In these types of structure the geometry of the riding surface should be adequately defined in terms of shape and amplitude of undulations and frequency, as this will have a significant effect on the dynamic loading on the structure.

(2) Other load effects such as cargo on and off loading can be measured using the principles outlined in C.2.1.

(3) Riding surfaces such as purpose-built test tracks may be used to obtain load histories for prototype designs. Load data from previous structures should be used with caution, as small differences, particularly in bogie design for example, can substantially alter the dynamic response. It is recommended that loading is verified on the final design if full scale fatigue testing is not to be adopted (see C.3).

C.3 Derivation of stress data

C.3.1 Component test data

(1) Where simple members occur such that the main force components in the member can be calculated or measured easily it will be suitable to test components containing the joint or constructional detail to be analysed.

(2) A suitable specimen of identical dimensions to that used in the final design should be gauged according to the simplified geometric stress assessment (see Annex D) using a convenient method such as electric resistance strain gauges, moiré fringe patterns or thermal elastic techniques. The ends of the component should be sufficiently far from the local area of interest that the local effects at the point of application of the applied loads do not affect the distribution of stress at the point. The force components and the stress gradients in the region of interest should be identical to those in the whole structure.

(3) Influence coefficients can be obtained from statically applied loads which will enable the stress pattern to be determined for any desired combination of load component. If required the coefficients can be obtained from scaled down specimens, provided the whole component is scaled equally.

C.3.2 Structure test data

(1) In certain types of structure such as shell structures the continuity of the structural material may make it impracticable to isolate components with simple applied forces. In this case stress data should be obtained from prototypes or production structures.

(2) Similar methods for measurement may be used as for component testing. For most general use it is recommended that static loads are applied as independent components so that the stresses can be combined using the individual influence coefficients for the point of interest. The load should go through a shakedown cycle before obtaining the influence coefficient data.

C.3.3 Verification of stress history

(1) The same method as described in C.3.2 may be used to verify the stress history at a point during prototype testing under a specified loading. In this case data acquisition equipment as used in C.2.1 should be used to record either the full stress history or to perform a cycle counting operation. The latter can be used to predict life once the appropriate $\Delta\sigma$ - N curve has been chosen.

(2) A further option, which may be used in the case of uncertain load histories, is to keep the cycle counting device permanently attached to the structure in service.

C.4 Derivation of endurance data

C.4.1 Component testing

(1) Whenever force spectra or stress history data are known component testing can be done to verify the design of critical parts of the structure. The component to be tested should be manufactured to exactly the same dimensions and procedures as are intended to be used in the final design. All these aspects should be fully documented before manufacture of the test component is carried out. In addition any method of non-destructive testing and the acceptance criteria should be documented, together with the inspector's report on the quality of the joints to be tested.

(2) The test specimens or components should be loaded in a similar manner to that described in C.2.1. Strain gauges, especially in the case of components, should be used to verify that the stress fluctuations are as required. The location of strain gauges should be such that they are recording the correct stress parameter. If the nominal stress is being recorded the gauge should be at least 10 mm from any weld toe. Where the stress gradient is steep three gauges should be used to enable interpolation to be carried out.

(3) Derivation of design endurance data from tests should follow the same statistical evaluation procedures as have been used for the establishment of the fatigue strength design values in 6.2. Usually this involves a statistical evaluation, based on estimates of mean and standard deviation, assuming a normal distribution, of observed logarithmic life cycles (dependent variable) for given logarithmic stress values (independent variable) or respectively a linear $\log\Delta\sigma$ - $\log N$ regression analysis for the different life ranges, see Figure 6.1. Thereby a mean regression line or a characteristic regression line for a specific probability of survival (usually ca. 97,7% or at 2 standard deviations from the mean) will be established. For design purposes the latter is assumed parallel to the first. The characteristic regression line, defined as above, should not be greater than 80% of the corresponding mean strength value. This allows for wider variations in production than is normally expected in a single set of fatigue specimens.

(4) It should be kept in mind that this simplified procedure of derivation of regression parameters is often applied although it may not be reliable in the case of small samples. For respective correction factors the procedures under C.4.3 give guidance.

(5) For damage tolerant design a record of fatigue crack growth with number of cycles should be obtained.

(6) Alternatively, if the design stress history is known and a variable amplitude facility is available the specimen may be tested under the un-factored stress history.

C.4.2 Full scale testing

- (1) Full scale testing may be carried out under actual operating conditions, or in a testing facility with the test load on the components applied by hydraulic or other methods of control.
- (2) The loads applied should not exceed the nominal loads.
- (3) Where the service loads vary in a random manner between limits they should be represented by an equivalent series of loads agreed between the supplier and the purchaser.
- (4) Alternatively, the test loads should equal the un-factored loads.
- (5) The application of loads to the sample should reproduce exactly the application conditions expected for the structure or component in service.
- (6) Testing should continue until fracture occurs or until the sample is incapable of resisting the full test load because of damage sustained.
- (7) The number of applications of test load(s) to failure should be accurately counted and recorded with observations of the progressive development of cracks.

C.4.3 Acceptance

- (1) The criterion for acceptance depends upon whether the structure is required to give a safe life performance, see statements (2) to (7), or damage tolerance performance, see statement (11).
- (2) For acceptance of a safe life design, the life to failure determined by test, adjusted to take account of the number of test results available, should not be less than the design life (defined in A.2.1) as follows:

$$T_L = \frac{T_m}{F} \quad (\text{C.1})$$

where:

T_L is the design life (in cycles)

T_m is the mean life to failure determined by test (in cycles)

F is the fatigue test factor dependent upon the effective number of test results available, as defined in Table C.1.

- (3) In estimating F factor values the following general statistical principles and assumptions apply. A characteristic statistical value is obtained by the expression

$$\chi_c = \mu - K\sigma \quad (\text{C.2})$$

where K depends on the probability distribution and the required probability of survival

for a statistical distribution with the mean μ and standard deviation σ . In practice only estimates for the mean and standard deviation, i.e. x_m and s respectively, may be calculated for a sample size n . Accordingly correction factors expressing the confidence intervals of both the mean and the variance (or standard deviation) have to be applied. The previous relationship may be thus expressed as

$$x_c = x_m - k \cdot s \quad (\text{C.3})$$

where:

$$k = k_1 k_2 + k_3$$

k_1 the theoretical value of the distribution belonging to a specific probability of survival

k_2 the correction for the confidence interval of the standard deviation

k_3 the correction for the confidence interval of the mean

k_2 and k_3 are dependent on the standard deviation s , sample size n , and on the prescribed level of confidence.

In the general case

$$k = k_1 k_2 + k_3 = Z_{(1-\alpha/2)} \sqrt{\frac{n}{\chi^2_{(\alpha/2, n-1)}}} + \frac{t_{(1-\alpha/2, n-1)}}{\sqrt{n}} \quad (\text{C.4})$$

where:

n is the sample size

α is the confidence level or probability value (in case of normal distribution)

$Z_{(1-\alpha/2)}$ is the value of the normal probability distribution with given probability of survival $(1-\alpha/2)$, corresponding to a two-sided-probability of $(1-\alpha)$

$\chi^2_{(\alpha/2, n-1)}$ is the value of the chi-square probability distribution for a given confidence interval of $\alpha/2$ and $n-1$ degrees of freedom

$t_{(1-\alpha/2, n-1)}$ is the value of the t-probability distribution for a given probability $(1-\alpha/2)$, corresponding to a two sided probability of $(1-\alpha)$ and $n-1$ degrees of freedom.

For the purpose of these rules the following assumptions are made:

- The standard deviation value is known from previous experience, i.e. based on a sufficiently large sample size, this allows k_2 to be set to unity;
- sufficient knowledge of the underlying distribution is available or no significant deviation from the normal distribution and;
- in the correction for the confidence interval for the mean the t -distribution may be replaced by the normal distribution.

(4) In the general case of more specimens all tested to failure expression (C.3) then becomes

$$k = k_1 + k_3 = Z_{(1-\alpha/2)} + \frac{Z_{(1-\alpha/2)}}{\sqrt{n}} \quad (\text{C.5})$$

(5) In the case of more specimens simultaneously tested until failure of first specimen and in order to estimate k , it is assumed that:

- The resulting life of the first specimen – relating to T_L from expression (C.1) - will lie on the upper boundary of the respective distribution;

— the required or design life – relating to T_m from expression (C.1) - will be at the lower boundary of the distribution.

The lower boundary will be derived from $x_m - k_1 s$, with k_1 according to expression (C.4). The upper boundary will be derived correspondingly from $x_m + k_4 s$. The appropriate value of k_4 is calculated from the assumption that if the probability of survival of one specimen, failing at the corresponding life, is P , then the probability of survival of n specimens at the same level will be P^n . To be on the safe side a sufficiently low value for $P^n = c$ will be defined, and k_4 is calculated from the normal distribution at $c^{1/n}$ probability for corresponding values n .

The factor k is then calculated from

$$k = k_1 + k_2 = Z_{(1-\alpha/2)} + Z_p \tag{C.6}$$

(6) From expression (C.1) the following expression is obtained:

$$\log T_L = \log T_m - \log F \tag{C.7}$$

which by comparison to expression (C.2) gives

$$\log F = k s \quad \text{or} \tag{C.8}$$

$$F = 10^{ks} \tag{C.5}$$

and F from Table C.1.

(7) The value of the standard deviation has to be estimated. Previous experience with similar structural cases provides more reliable values. Data available (References C.1 and C.2) for various aluminium welded constructional details give a range of different standard deviation values $s_{\log\Delta\sigma}$. These may be transformed by the respective average regression line slope of $m = 4$ to values $s_{\log N}$ for the life range up to the constant amplitude fatigue limit of 5×10^6 cycles. For lives up to 10^8 cycles it may be appropriate to use larger scatter values according to the slope $m+2$. Special considerations will be needed beyond this limit.

(8) The values F calculated on the basis of the above statistical relations and given in Table C.1.

(9) The values in Table C.1 are based on a probability of survival of 95% and a confidence level of 0,95 for the normal distribution and a standard deviation value of $s_{\log N} = 0,18$. In the case of first sample to fail a probability of survival value of $P^n = 5\%$ is assumed.

(10) Criteria for factoring the measured life and for acceptance will vary from one application to another and should be agreed with the engineer responsible for acceptance.

(11) Acceptance of a damage tolerance design is dependent upon the life of a crack reaching a size which could be detected by a method of inspection which can be applied in service. It also depends on the rate of growth of the crack, critical crack length considerations, and the implications for the residual safety of the structure and the costs of repair.

Table C.1 —Fatigue test factor F

Test result	Sample size n											
	1	2	3	4	5	6	8	10	15	20	30	100
Identical samples all tested to failure.	3,91	3,20	2,93	2,78	2,68	2,61	2,52	2,45	2,36	2,30	2,24	2,12
Identical samples all tested simultaneously. First sample to fail.	3,91	2,71	2,27	2,03	1,88	1,77	1,61	1,51	1,36	1,26	1,15	0,91

C.5 Crack growth data

Guidance on derivation of crack growth data is given in Annex B.

C.6 Reporting

(1) At the conclusion of any testing performed in accordance with this section a test certificate should be compiled containing the following information:

- a) Name and address of the testing laboratory;
- b) accreditation reference of the test facility (where appropriate);
- c) date of test;
- d) name(s) of the person responsible for the testing;
- e) description of sample tested, by means of:
 - 1) reference to serial number where appropriate; or
 - 2) reference to drawing number(s) where appropriate; or
 - 3) description with sketches or diagrams; or
 - 4) photographs;
- f) description of load systems applied including references to other European Standards where appropriate;
- g) record of load applications and measured reactions to load, i.e. deflection, strain, life;
- h) summary of loads and deformations and stress at critical acceptance points;
- i) record of endurance and mode of failure;
- j) record of locations of observations by reference to e)2) to e)4) above;
- k) notes of any observed behaviour relevant to the safety or serviceability of the object under test, e.g. nature and location of cracking in fatigue test;
- l) record of exposure conditions at time of testing where relevant;
- m) statement of validation authority for all measuring equipment used;
- n) definition of purpose or objectives of test;
- o) statement of compliance or non-compliance with relevant acceptance criteria as appropriate;
- p) record of names and status of persons responsible for testing and issuing of report;
- q) report denotation and date of issue.

Annex D [informative]: Stress analysis

D.1 Use of finite elements for fatigue analysis

D.1.1 Element types

D.1.1.1 Beam elements

(1) Beam elements are mainly used for analysis of nominal stresses in frames and similar structures. A conventional beam element for analysis of three dimensional frames has 6 degrees of freedom at each end node: three displacements and three rotations. This element can describe the torsional behaviour correctly only in cases in which the cross section is not prone to warp, or warping can occur freely. Analysis of warping stresses is impossible, when open thin-walled structures are analysed.

(2) Usually, the beam elements are rigidly connected to each other at the nodal points. Alternatively, pinned joints can also be specified. However, in many structures the joints are semi-rigid. In addition, in tubular joints the stiffness is unevenly distributed, which causes extra bending moments. Such structural features require more sophisticated modelling than the use of rigid or pinned joints.

D.1.1.2 Membrane elements

(1) Membrane elements are intended for modelling plated structures which are action in-plane. They cannot deal with shell bending stresses. Triangular and rectangular plate elements are suitable for solving nominal membrane stress fields in large stiffened plate structures.

D.1.1.3 Thin shell elements

(1) Finite element programs contain various types of thin shell elements. These include flat elements, single curvature elements and double curvature elements. The deformation fields are usually formulated as linear (4-noded element) or parabolic (8-noded element). In general, thin shell elements are suitable for solving the elastic structural stresses according to the theory of shells. The mid-plane stress is equal to the membrane stress, and the top and bottom surface stresses are superimposed membrane and shell bending stresses.

(2) Thin shell elements can only model the mid-planes of the plates. The actual material thickness is given as a property only for the element. There are also thin shells with tapered thickness, which are useful for modelling cast structures, for example. The most important drawback with thin shell elements is that they cannot model the real stiffness and stress distribution inside, and in the vicinity of, the weld zone of intersecting shells.

D.1.1.4 Thick shell elements

(1) Some finite element packages also include so-called thick shell elements. These allow transverse shear deformation of the shell in the thickness direction to be taken into account. Thick shell elements work better than thin shell elements in e.g. constructional details in which the distance between adjacent shell intersections is small, giving rise to significant shear stresses.

D.1.1.5 Plane strain elements

(1) Sometimes it is useful to study the local stress fields around notches with a local 2-D model. A cross section of unit thickness can then be modelled as a two dimensional structure using plane strain elements.

D.1.2 Further guidance on use of finite elements

(1) Solid elements are needed for modelling structures with three dimensional stress and deformation fields. Curved isoparametric 20-noded elements are generally the most suitable. In welded components, they are sometimes required for modelling the intersection zone of the plates or shells.

(2) Solid elements with linear displacement formulation are not recommended because of insufficient convergence with increasing mesh refinement.

(3) 10-node quadratic tetrahedron solid elements are very efficient for automatic mesh generation and have a good convergence behaviour.

D.2 Stress concentration factors

(1) Values of stress concentration factors and notch factors for commonly occurring geometries can be obtained from published data (see References D.1 and D.2).

(2) Typical values of K_{gt} for rounded corners in flat plate are given in Figure D.1.

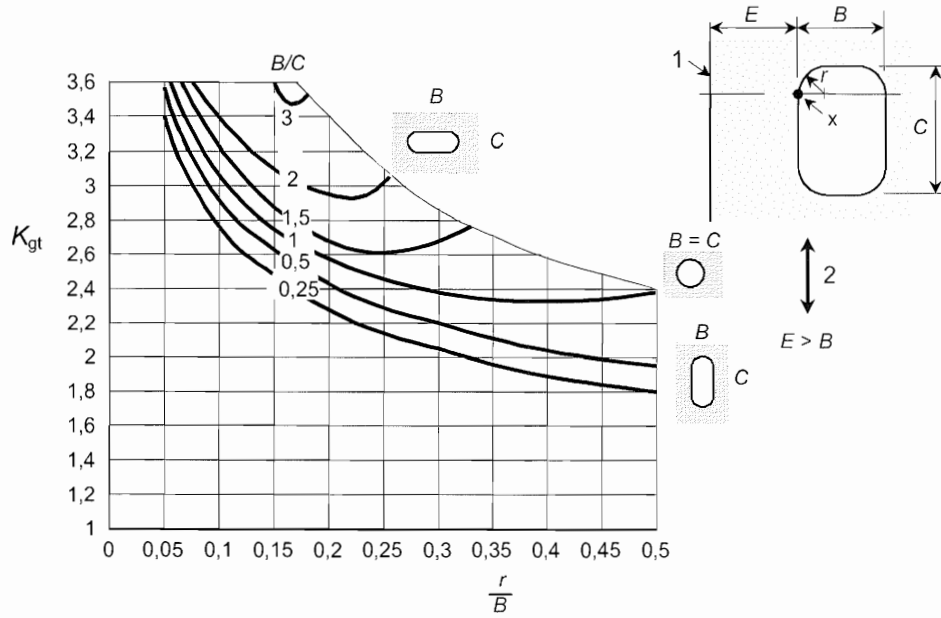

a) Fatigue stress concentration factor K for unreinforced apertures based on net stress at X
1 – free edge; 2 – stress fluctuation

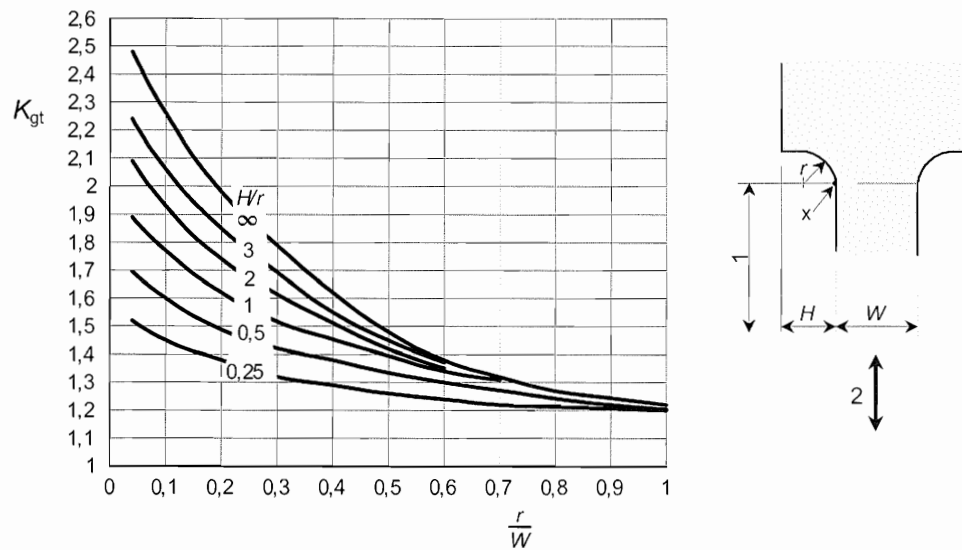

b) Fatigue stress concentration factor K for re-entrant corners based on net stress at X
1 – length of straight $> 2r$; 2 – stress fluctuation

Figure D.1 – Typical stress concentration factors from rounded corners in flat plate

D.3 Limitation of fatigue induced by repeated local buckling

(1) The slenderness of plate elements should be limited to avoid repeated local buckling that might result in fatigue at or adjacent to edge connections.

(2) Excessive repeated local buckling may be neglected if the following criterion is met:

$$\sqrt{\left(\frac{\sigma_{x,Ed,ser}}{k_{\sigma}\sigma_E}\right)^2 + \left(\frac{1,1\tau_{x,Ed,ser}}{k_{\tau}\sigma_E}\right)^2} \leq 1,1 \quad (D.1)$$

where:

$\sigma_{x,Ed,ser}$, $\tau_{x,Ed,ser}$ are the stresses for the frequent load combination.

k_{σ} , k_{τ} are the linear elastic buckling coefficients assuming hinged edges of the plate element.

$$\sigma_E = 0,904 E (t_w/b_w)^2$$

t_w , b_w are the thickness and the depth of the web panel.

NOTE The term web breathing may be encountered in literature having the same meaning as repeated local buckling.

Annex E [informative]: Adhesively bonded joints

(1) Design of adhesively bonded joints should consider the following:

- Peel action should be reduced to a minimum;
- stress concentrations should be minimized;
- strains in the parent metal should be kept below yield;
- chemical conversion or anodizing of the surfaces improves adhesion compared to degreasing or mechanical abrasion;
- aggressive exposure conditions usually reduce fatigue life.

(2) For lap joints failing in the bond plane, the effective shear stress range $\Delta\tau$ should be based on the force per unit width of the joint divided by the effective length of the lap L_{adh} , where:

$$L_{adh} = \text{lap length } L, \text{ where } L \leq 15 \text{ mm}$$

$$L_{adh} = 15 \text{ mm, where } L > 15 \text{ mm}$$

(3) The reference fatigue strength of an adhesively bonded double lap joint which fails in the bond line is defined by the equation:

$$\Delta\tau_{C,adh} = k_{C,adh} \cdot f_{v,adh} \tag{E.1}$$

where:

$k_{C,adh}$ is the value of the adhesive joint fatigue strength factor k_{adh} at $N_C = 2 \times 10^6$ cycles

$f_{v,adh}$ is the characteristic shear strength of the adhesive obtained from a standard static lap shear test (see EN 1999-1-1)

Table E.1 — Adhesively bonded joints

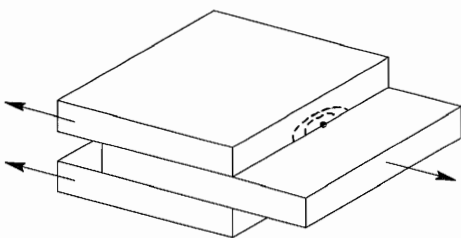
Detail category	Product forms Constructional detail Initiation site	Stress analysis	Execution requirements
$0,11 f_{v,adh}$ $m_1 = 6$ $m_2 = 6$	Rolled, extruded and forged products Single and two-component epoxies Lap joint, thickness of thinner part ≤ 8 mm  In bondline at leading edge	Stress normal to leading edge Stress peak at leading edge, eccentricity of load path in symmetrical double covered lap joints only	Machining only by high speed milling cutter Surface Preparation: degreasing or chromate conversion Assembly: bondline thickness within tolerances specified for shear strength test

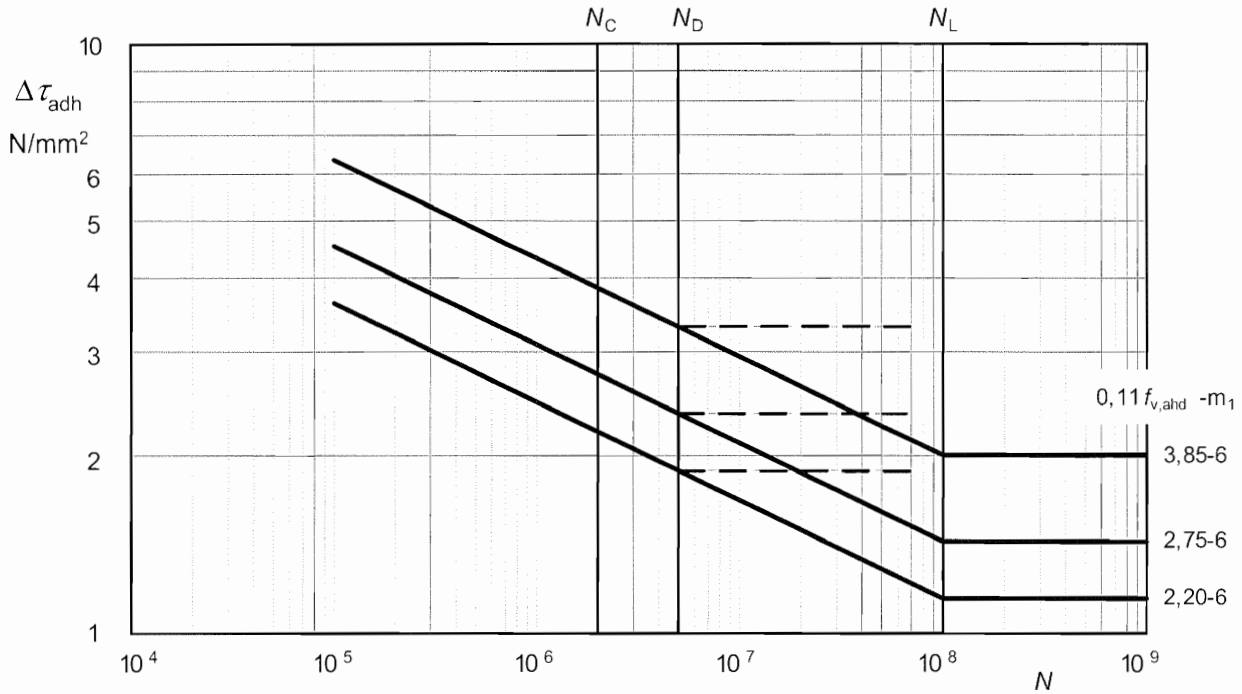

Fatigue shear strength curve: 3,85-6 single-component, heat cured, modified epoxide, $f_{v,adh} = 35 \text{ N/mm}^2$
 Fatigue shear strength curve: 2,75-6 two-components, cold cured, modified epoxide, $f_{v,adh} = 25 \text{ N/mm}^2$
 Fatigue shear strength curve: 2,20-6 two-components, cold cured, modified acrylic, $f_{v,adh} = 20 \text{ N/mm}^2$

Figure E.1 — $\Delta\tau_{adh}$ - N curve for adhesively bonded joints

Table E.2 — Numerical values for $k_{adh} (= \Delta\tau/f_{v,adh})$ for adhesively bonded joints

Detail Category ($N = 2 \times 10^6$)		$N = 10^5$	$N_D = 5 \times 10^6$	$N_L = 10^8$
$\Delta\tau_{C,adh}/f_{v,adh}$	m_1	$\Delta\tau_D/f_{v,adh}$	$\Delta\tau_D/f_{v,adh}$	$\Delta\tau_L/f_{v,adh}$
0,11	6	0,181	0,094	0,065

(4) The fatigue design relationship for endurance in the range between 10^5 to 5×10^6 cycles or in the range between 5×10^6 to 10^8 cycles is defined as in 6.2.1 (2) and 6.2.1 (4) respectively in this document.

(5) The design strength values for adhesively bonded joints should apply a partial factor γ_{Mf} to the above given strength values.

NOTE The partial factor γ_{Mf} for specific constructional detail types may be defined in the National Annex. The value of $\gamma_{Mf} = 3,0$ is recommended.

(6) Testing under representative conditions of geometry, workmanship and exposure conditions is recommended for critical applications.

(7) Fatigue data for adhesively bonded joints applies only within a temperature range of $-20 \text{ }^\circ\text{C}$ and $+60 \text{ }^\circ\text{C}$.

NOTE The temperature limits given are based on available test data. Other values may be defined by the National Annex, if they are justified by test according to Annex C.

(8) No allowance should be made for effect of mean stress without justification by test (see Annex C).

Annex F [informative]: Low cycle fatigue range

F.1 Introduction

(1) Where significant damage is done by high stress ranges which are applied less than 10^5 times, the $\Delta\sigma$ - N curves given in 6.2 for certain constructional details and R -ratios may be unnecessarily conservative. The data below may be used to obtain a more accurate life prediction.

F.2 Modification to $\Delta\sigma$ - N curves

(1) For endurance between 10^3 and 10^5 cycles the fatigue design curve may be defined as:

$$N_i = \left(\frac{\Delta\sigma_C}{\Delta\sigma_i} \frac{1}{\gamma_{Ff} \gamma_{Mf}} \right)^{m_0} \cdot 20^{\frac{m_0}{m_1}} \cdot 10^5 \quad (\text{F.1})$$

where:

- N_i is the calculated number of cycles to failure of a stress range $\Delta\sigma_i$
- $\Delta\sigma_C$ is the reference value of fatigue strength at 2×10^6 cycles depending on the detail category
- $\Delta\sigma_i$ is the stress range for the principal stresses at the detail and is constant for all cycles
- m_0 is the inverse logarithmic slope of the $\Delta\sigma$ - N curve in the range 10^3 and 10^5 cycles, depending on the detail category, alloy and R -value
- m_1 is the inverse logarithmic slope of the $\Delta\sigma$ - N curve, depending on the detail category
- γ_{Ff} is the partial factor allowing for uncertainties in the loading spectrum and analysis of response (see 2.4);
- γ_{Mf} is the partial factor for uncertainties in materials and execution (see 6.2.1(2)).

F.3 Test data

(1) Table F.1 gives values of m_0 for selected constructional details in certain wrought alloy products which have been derived from test data.

NOTE 1 For R -ratios between $R = -1$ and $R = 0$ a linear interpolation of inverse m_0 value may be used.

NOTE 2 The R -value may be based on the applied stresses only without taking into account residual stresses.

Table F.1 —Values of m_0

Detail Type	Detail Category Table	Alloys	Product Form	m_0	
				$R = -1$	$R \geq 0$
1.1	J.1	7020	Sheet, plate and simple extrusions	5,0	m_1
1.2		6000 series ¹⁾	Sheet, plate and simple extrusions	4,0	m_1
1.3		7020	Shaped extrusions	4,0	m_1
1.4		6000 series ¹⁾	Shaped extrusions	4,0	m_1
7.6	J.7 and J.9	EN 1999-1-1, Table 3.1a ¹⁾		3,0	m_1
9.1				3,0	m_1
9.2				3,0	m_1
9.3				3,0	m_1
9.4				3,0	m_1
15.1	J.15	7020	EN 1999-1-1, Table 3.1a	3,3	m_1
15.2		7020		3,3	m_1

¹⁾ Exceptions - see 3(1)

Annex G [informative]: Influence of R -ratio

G.1 Enhancement of fatigue strength

(1) For applied stress ratio values less than $R = +0,5$ an enhanced reference fatigue strength $\Delta\sigma_{C(R)}$ may be used in place of $\Delta\sigma_C$ as follows:

$$\Delta\sigma_{C(R)} = f(R) \Delta\sigma_C \quad (\text{G.1})$$

where:

$f(R)$ is the enhancement factor depending on the R -ratio and the type of component and constructional detail, as given in G.2. below.

NOTE Drawn tubes and formed profiles (folded; roll-formed) may have residual stresses, which are not negligible, so that an enhancement according to this Annex may not be allowed.

G.2 Enhancement cases

G.2.1 Case 1

(1) This applies to initiation sites in the base material and wrought products in structural elements remote from connections.

(2) Allowance should be made for any pre-action or lack of fit in addition to the applied stresses.

(3) The values of the enhancement factor $f(R)$ are given by

$$f(R) = 1,2 - 0,4R \quad (\text{G.2})$$

see also Table G.1 and Figure G.1.

Table G.1 – Values of $f(R)$ for Case 1

R	$f(R)$
≤ -1	1,6
> -1 $< +0,5$	$1,2 - 0,4R$
$\geq +0,5$	1,0

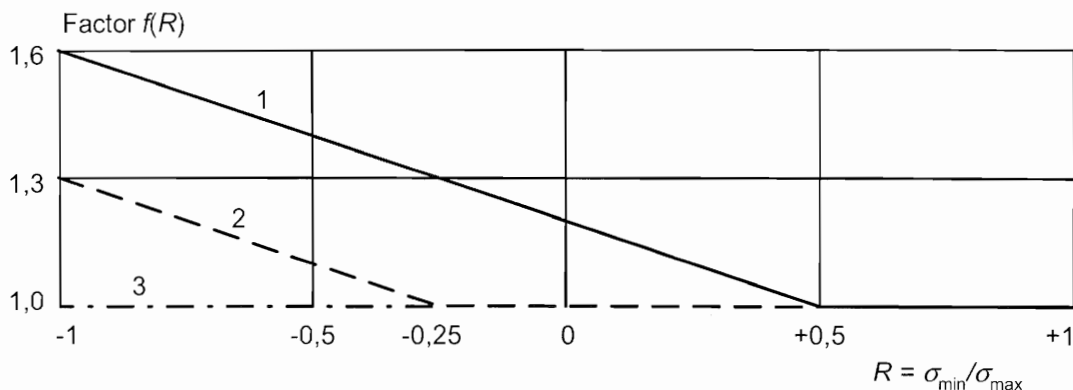

1 – fully stress free regions; 2 – partially stress free regions; 3 – regions with residual stresses

Figure G.1 —Strength enhancement factor $f(R)$ at 2×10^2 cycles

G.2.2 Case 2

(1) This applies to initiation sites associated with welded or mechanically fastened connections in simple structural elements, where the residual stresses σ_{res} has been established, taking into account any preaction or lack of fit.

(2) The effective R -ratio R_{eff} should be estimated as follows:

$$R_{eff} = \frac{2\sigma_{res} - \Delta\sigma}{2\sigma_{res} + \Delta\sigma} \tag{G.3}$$

where:

$\Delta\sigma$ is the applied stress range.

(3) The values of $f(R)$ are given by

$$f(R) = 0,9 - 0,4R \tag{G.4}$$

see also Table G.2 and Figure G.1.

Table G.2 – Values of $f(R)$ for Case 2

R_{eff}	$f(R)$
≤ -1	1,3
> -1	0,9 - 0,4R
$< -0,25$	
$\geq -0,25$	1,0

G.2.3 Case 3

(1) This applies near welded connections and to complex structural assemblies where control of residual stresses is not practicable.

(2) In this case $f(R)$ should be taken as unity for all R -ratios (see also Figure G.1).

Annex H [informative]: Fatigue strength improvement of welds

H.1 General

(1) In cases where the fatigue cracks would initiate at the weld toe, the capacity of welded joints can be improved. Such methods are normally used at the most highly stressed welds or for improving welds having low strength.

(2) The following methods are considered here:

- Machining or grinding;
- dressing by TIG or plasma;
- peening (shot peening, needle peening or hammer peening).

(3) In cases where specified improvement techniques have been employed, an improvement at the mid and long fatigue life region up to 30% measured by stress range may be obtained. The highest improvement is achieved by the combination of two methods like machining (or grinding) and hammer peening where the double improvement of the individual methods can be reached.

(4) For all methods the following aspects should be considered:

- a) A suitable work procedure should be available;
- b) Before applying the measures for improvement it should be assured that no surface cracks are present in the critical locations.
- c) This should be done by dye penetrant or other suitable NDT methods;
- d) In the short life region where the local stresses exceed the yield strength the initiation period is a small fraction (irrespective of the notch case) and the improvement is thus small. Hence, there will be no improvement in design at 10^5 cycles. (The $\Delta\sigma - N$ curve is thus rotated with fixed values at 10^5);
- e) Potential fatigue fracture locations other than that being improved should be considered: e.g. if the weld toe area is improved, then locations like the weld throat or internal cracks (partial penetration), might be the limiting factor;
- f) The fatigue life and the usefulness of improvement methods should be considered;
- g) Under freely corroding conditions in water, the improvement is often lost. Methods involving compressive residual stresses (peening) are less susceptible. Corrosion protection is therefore needed if the improvement is to be achieved.

(5) Design values for improved welds should be established by testing, see Annex C.

H.2 Machining or grinding

(1) Machining can be performed by a high speed rotary burr cutter and has the advantages of producing a more precise radius definition, leaving marks parallel to the stress direction and gaining access to corners. Alternatively a disk grinder may be used if access permits, see Figure H.1. In both cases the radius of the cutting tip or edge should be correctly chosen.

(2) To ensure the removal of intrusions etc. burr machining has to be extended to a depth of minimum 0.5 mm below the bottom of any visible undercut etc., but should not exceed 2 mm or 5% of the plate thickness, whichever is the less see Figure H.2. The slight reduction in plate thickness and corresponding increase in nominal stress is insignificant for thickness of 10 mm or larger. In the case of multipass welds at least two weld toes should be treated. Care should also be taken to ensure that the required throat size is maintained.

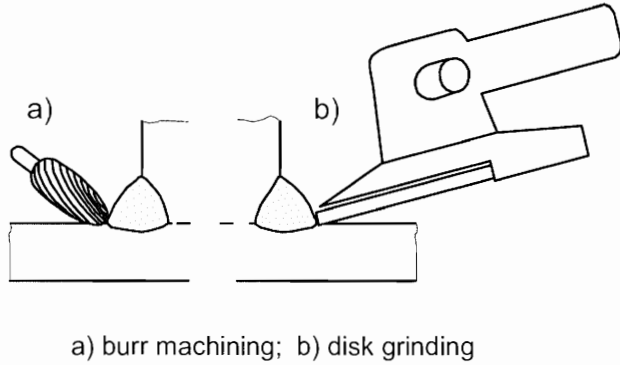

Figure H.1 —Machining/grinding techniques

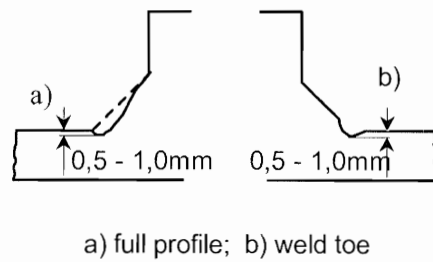

Figure H.2 —Profile Geometries

H.3 Dressing by TIG or plasma

(1) While TIG welding is only a practical process for structures made of plates 4 mm thick or less, it can be used for improving the fatigue strength in cases where the weld toe is the critical site. When re-melting the existing toe region inclusions and undercuts can be removed and the toe radius can be increased which reduces the local stress concentration factor.

(2) Standard TIG dressing equipment should be used, without the addition of any filler material. TIG dressing is sensitive to operator skills and it is important to have clean surfaces to avoid pores. Detailed procedures should be prepared.

(3) The improvement should be verified by tests.

H.4 Peening

(1) The largest benefits are normally obtained with methods where compressive residual stresses are introduced. The most common methods are hammer peening, needle peening, and shot peening. Peening is a cold working process where the impact of a tool deforms the surface plastically. The surrounding (elastic) material will compress the deformed volume. High compressive service action can decrease the level of residual stress and should be taken into account when applying random action spectra.

(2) Procedures for all peening methods should be prepared: Passes, weld toe deformation, and indentation for hammer and wire bundle peening; intensity, coverage, and Almen strip deformation for shot peening.

Annex I [informative]: Castings

I.1 General

(1) The following data may be used for castings provided that the rules for calculation of stresses in EN 1999-1-1 clause 3.2.3.1 and its Annex C.3.4 are followed.

(2) The design rules in EN 1999-1-3 for castings under fatigue loading, for the alloys given in EN 1999-1-1, Table 3.3, may be used if the additional requirements in I.3 are observed.

I.2 Fatigue strength data

I.2.1 Plain castings

(1) Depending on the required level of quality, see I.3, the numerical values for $\Delta\sigma$ of Table I.1 may be applied.

Table I.1 – Numerical values of $\Delta\sigma$ (N/mm²) for plain material

Detail Category ($N_C = 2 \times 10^6$)		$N = 10^5$	$N_D = 2 \times 10^6$	$N_L = 10^8$
$\Delta\sigma_C$	$m_1 = m_2$	$\Delta\sigma$	$\Delta\sigma_D$	$\Delta\sigma_L$
71 ¹⁾	7	108,9	71	40,6
50	7	76,7	50	28,6
40	7	61,4	40	22,9
32	7	49,1	32	18,3
25	7	38,4	25	14,3

¹⁾ see NOTE in I.3

I.2.2 Welded material

(1) Fatigue strength values for welded castings are not covered by EN 1999-1-3.

NOTE Fatigue strength values for welded joints of castings may be defined in the National Annex.

I.2.3 Mechanically joined castings

I.2.3.1 Bolted joints

(1) The numerical values $\Delta\sigma$ of Table I.2 may be applied for bolts of Category A: Bearing Type, see EN 1999-1-1.

Table I.2 — Numerical values of $\Delta\sigma$ (N/mm²) for bolted joints

Detail Category ($N_C = 2 \times 10^6$) for plain material	Corresponding Detail Category ($N_C = 2 \times 10^6$) for bolted joints		$N = 10^5$	$N_D = 5 \times 10^6$	$N_L = 10^8$
	$\Delta\sigma_C$	$m_1 = m_2$			
71	45	4	95,2	35,8	16,9
50	40	4	84,6	31,8	15,0
40	25	4	52,9	19,9	9,4
32	20	4	42,3	15,9	7,5
25	16	4	33,8	12,7	6,0

I.2.3.2 Pinned joints

(1) Fatigue strength values for pinned joints are not covered by EN 1999-1-3.

NOTE 1 Fatigue strength values of Table J.15 for bolted joints may be used provided that design analysis considers adequately and reliably the stress distribution along the pin and the member, e.g. by geometric stress calculation.

NOTE 2 Fatigue strength values for pinned joints of castings may be defined in the National Annex.

I.2.4 Adhesively bonded castings

(1) Adhesively bonded joints in castings are not covered by EN 1999-1-3.

NOTE Fatigue strength values for adhesively bonded joints in castings may be defined in the National Annex.

I.3 Quality requirements

(1) The additional limitations in Table I.3 concerning maximum pore diameter should be observed.

Table I.3 – Values for maximum pore diameter [mm] for castings

Detail Category ($N_C = 2 \times 10^6$)	71	50	40	32	25
maximum pore diameter	0,2	0,5	0,9	1,5	2,0 (normal)

NOTE Producing castings with pore diameter less than 0,6 mm requires special skill, experience and cast technique and technology. Furthermore detecting pores less than 0,6 mm requires special equipment especially for the range up to 0,2 mm, where the possibility of detecting flaws of such a size depends also on the shape (thickness) of the casting. Assumptions made for the material properties of castings, to be used in the structural design, should be confirmed by the casting manufacturer.

Annex J [informative]: Detail category tables

J.1 General

(1) The detail categories and the $\Delta\sigma - N$ relationships in this Annex may only be used with the provisions of Chapter 6.

(2) The detail category values are valid for ambient temperature, exposure conditions which do not require any surface protection (see Table 6.2), and in connection with the execution requirements of EN 1090-3. These values are derived for stress ratio values not smaller than 0,5.

Table J.1 – Detail categories for plain members

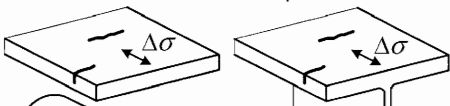
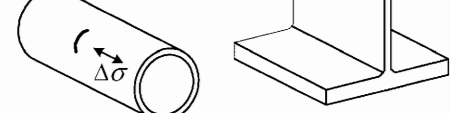
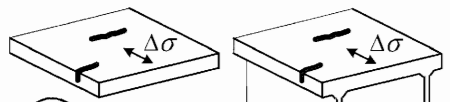
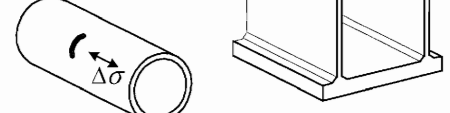
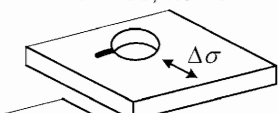
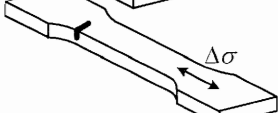
Detail type	Detail category $\Delta\sigma - m_1$ ¹⁾ Alloy restriction	Product forms Constructional detail Initiation site	Stress orientation	Stress analysis	Execution requirements	
1.1	125-7 7020 only	Sheet, plate and simple extruded rod and bar, machined parts 	Parallel or normal ²⁾ to rolling or extrusion direction	Principal nominal stress at initiation site	No re-entrant corners in profile, no contact with other parts Machined with a surface finish $R_{z5} < 40 \mu\text{m}$ Visual inspection	
1.2	90-7	Surface irregularity 				
1.3	80-7 7020 only	Sheet, plate, extrusions, tubes, forgings 				
1.4	71-7	Surface irregularity 			Account for stress concentration: see D.2	Surface free of sharp corners unless parallel to stress direction, edges free of stress raisers
1.5	140-7 7020 only	Notches, holes 				
1.6	100-7	Surface irregularity 				
¹⁾ $m_1 = m_2$, constant amplitude fatigue limit at 2×10^6 cycles ²⁾ If the stress orientation is normal to the extrusion direction the manufacturer should be consulted concerning the quality assurance in case of extrusions by port hole or bridge die. ³⁾ R_{z5} see EN-ISO 4287 and EN-ISO 4288						

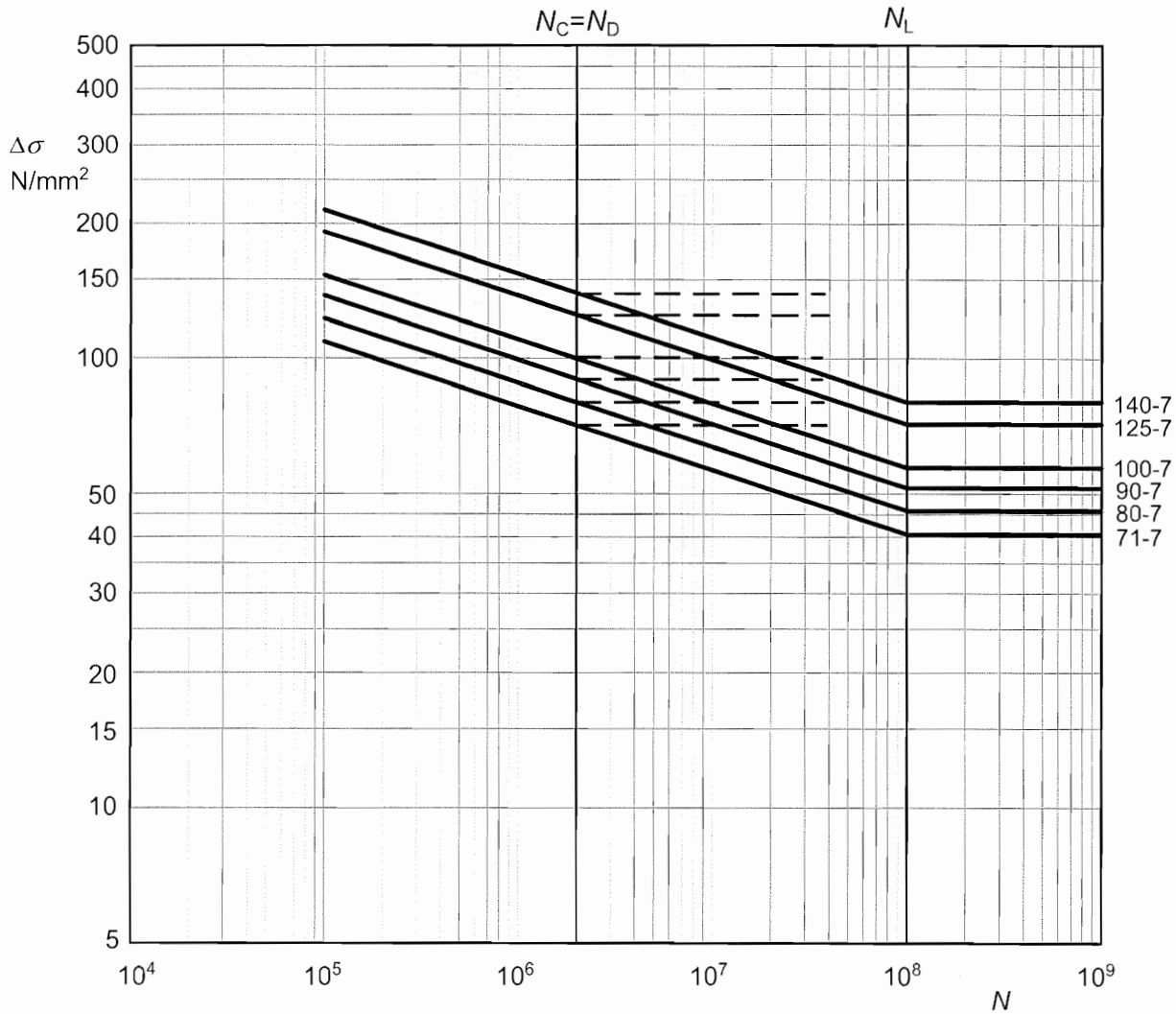
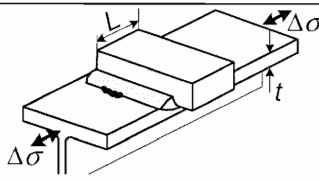
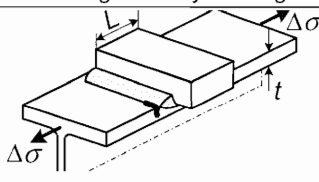
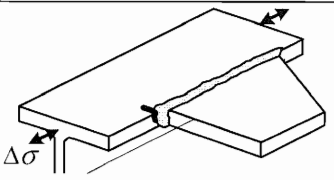
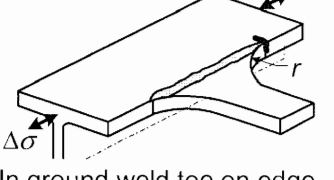
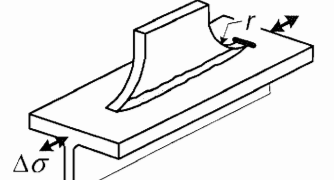
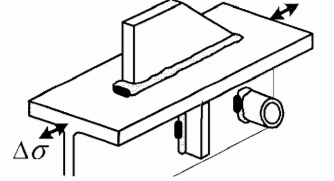

Figure J.1 —Fatigue strength curves $\Delta\sigma$ - N for plain members - categories as in Table J.1

Table J.2 – Numerical values of $\Delta\sigma$ - N (N/mm^2) for plain members - detail categories as in Table J.1

Slope		Cycles N						
m_1	m_2	1E+05	1E+06	2E+06	5E+06	1E+07	1E+08	1E+09
7,0	7,0	214,8	154,6	140,0	122,8	111,2	80,1	80,1
7,0	7,0	191,8	138,0	125,0	109,7	99,3	71,5	71,5
7,0	7,0	153,4	110,4	100,0	87,7	79,5	57,2	57,2
7,0	7,0	138,1	99,4	90,0	79,0	71,5	51,5	51,5
7,0	7,0	122,7	88,3	80,0	70,2	63,6	45,7	45,7
7,0	7,0	108,9	78,4	71,0	62,3	56,4	40,6	40,6

Table J.3 – Detail categories for members with welded attachments – transverse weld toe

Detail type	Detail category $\Delta\sigma - m_1$ ^{1) 2)}	Constructional detail Initiation site	Dimensions (mm)	Stress analysis		Execution requirements		
				Stress parameter	Stress already allowed for		Quality level ³⁾	
3.1	32-3,4		$L \leq 20$	Nominal stress at initiation site	Stiffening effect of attachment	Grind undercut smooth	C	
3.2	25-3,4 $t \leq 4$ 23-3,4 $4 < t \leq 10$ 20-3,4 $10 < t \leq 15$	At transverse weld toe on stressed member, away from edge (weld continued longitudinally at flange edge)	$L > 20$					
3.3	28-3,4		$L \leq 20$					
3.4	23-3,4 $t \leq 4$ 20-3,4 $4 < t \leq 10$ 18-3,4 $10 < t \leq 15$	At transverse weld toe on stressed member at corner (weld continued longitudinally at flange edge)	$L > 20$					
3.5	18-3,4		No radius					
3.6	36-3,4		$r \geq 50$					Grind radius parallel to stress direction. Weld toe should be fully ground out
3.7	36-3,4		$r \geq 50$					
3.8	23-3,4		No radius					

¹⁾ $m_2 = m_1 + 2$
²⁾ For flat members under bending stresses see 6.2.1(11) and increase by two detail categories.
³⁾ According to EN ISO 10042:2005

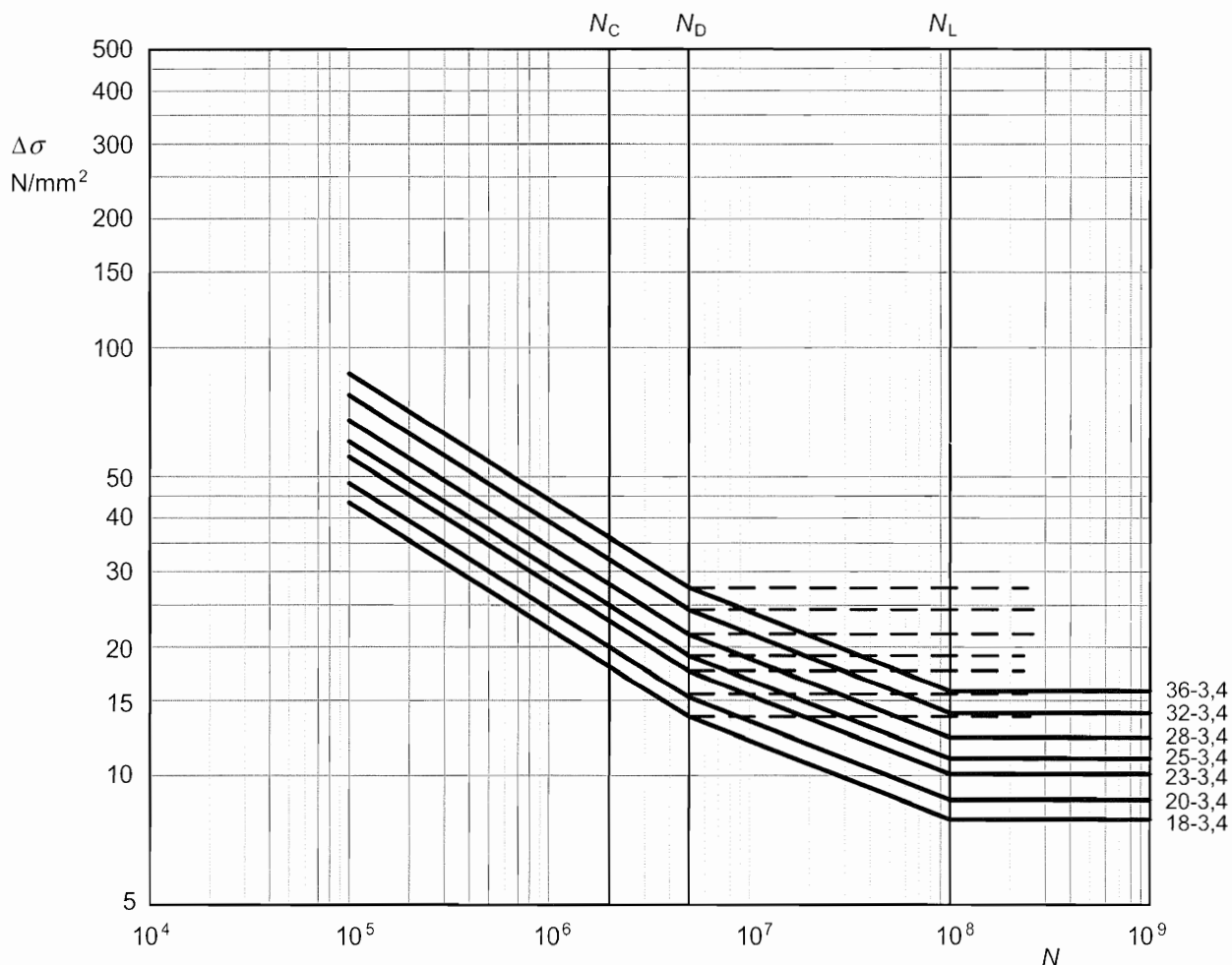
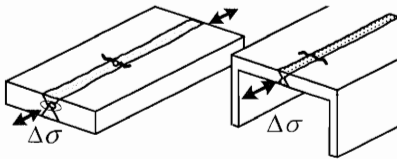
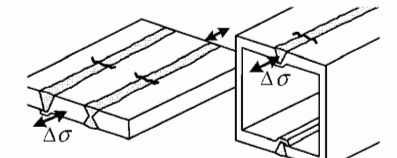
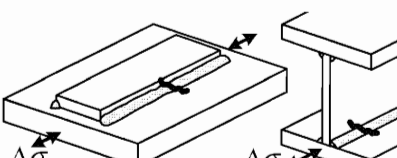
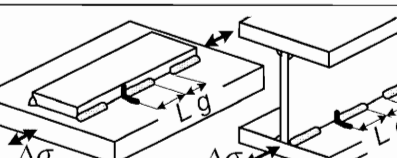
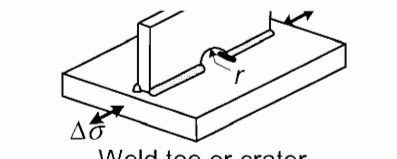

Figure J.2 – Fatigue strength curves $\Delta\sigma-N$ for members with welded attachments, transverse weld toe – detail categories as in Table J.3

Table J.4 – Numerical values of $\Delta\sigma-N$ (N/mm²) for welded attachments, transverse weld toe – detail categories as in Table J.3

Slope		Cycles N						
m_1	m_2	1E+05	1E+06	2E+06	5E+06	1E+07	1E+08	1E+09
3,4	5,4	86,9	44,1	36,0	27,5	24,2	15,8	15,8
3,4	5,4	77,2	39,2	32,0	24,4	21,5	14,0	14,0
3,4	5,4	67,6	34,3	28,0	21,4	18,8	12,3	12,3
3,4	5,4	60,3	30,7	25,0	19,1	16,8	11,0	11,0
3,4	5,4	55,5	28,2	23,0	17,6	15,5	10,1	10,1
3,4	5,4	48,3	24,5	20,0	15,3	13,4	8,8	8,8
3,4	5,4	43,4	22,1	18,0	13,7	12,1	7,9	7,9

Table J.5 – Detail categories for members with longitudinal welds

Detail type	Detail category $\Delta\sigma - m_1$ ¹⁾	Constructional detail Initiation site	Weld type	Stress analysis		Execution requirements			
				Stress parameter	Stress concentrations already allowed for	Welding characteristics	Quality level ³⁾ internal surface and geometric	additional	
5.1	63-4,3	 At weld discontinuity	Full penetration butt weld Weld caps ground flush	Nominal stress at initiation site		Continuous automatic welding	B	C	2)
5.2	56-4,3						C	C	
5.3	45-4,3	 At weld discontinuity	Full penetration butt weld			Any backing bars to be continuous	C	D	
5.4	45-4,3	 At weld discontinuity	Continuous fillet weld			B	C		
5.5	40-4,3					C	D		
5.6	36-4,3	 Weld toe or crater	Intermittent fillet weld $g \leq 25L$			C	D		
5.7	28-4,3	 Weld toe or crater	Cope hole centred on weld axis $r \leq 25$			Presence of cope hole	C	D	

¹⁾ $m_2 = m_1 + 2$

²⁾ Discontinuity in direction of longitudinal weld should be not longer than 1/10 of the plate thickness or exhibit a slope steeper than 1:4.

³⁾ According to EN ISO 10042:2005

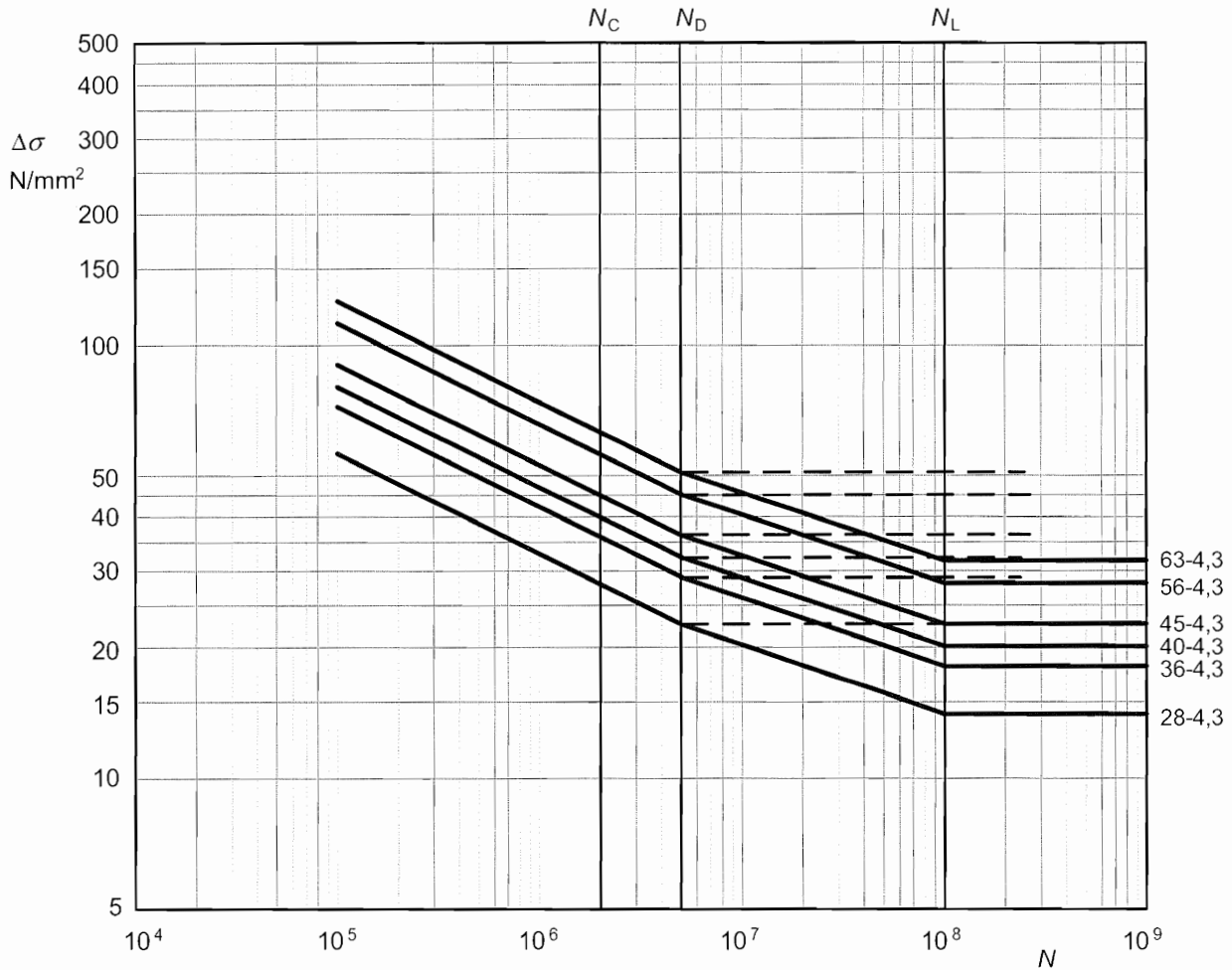
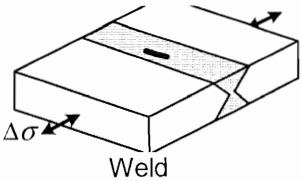
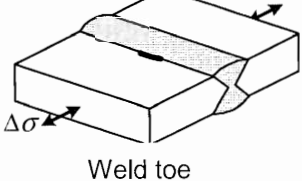
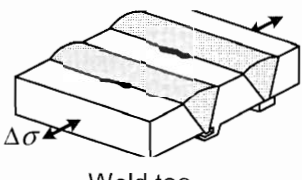
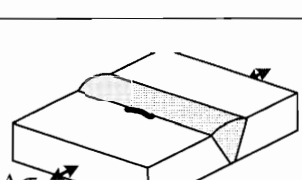
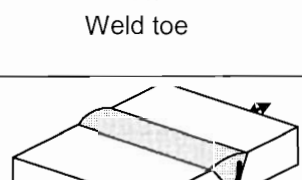
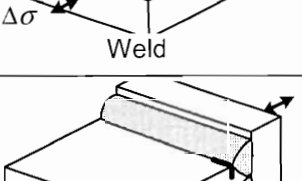

Figure J.3 – Fatigue strength curves $\Delta\sigma$ - N for members with longitudinal welds - detail categories as in Table J.5

Table J.6 – Numerical values of $\Delta\sigma$ - N (N/mm²) with longitudinal welds - detail categories as in Table J.5

Slope		Cycles N						
m_1	m_2	1E+05	1E+06	2E+06	5E+06	1E+07	1E+08	1E+09
4,3	6,3	126,4	74,0	63,0	50,9	45,6	31,6	31,6
4,3	6,3	112,4	65,8	56,0	45,3	40,5	28,1	28,1
4,3	6,3	90,3	52,9	45,0	36,4	32,6	22,6	22,6
4,3	6,3	80,3	47,0	40,0	32,3	29,0	20,1	20,1
4,3	6,3	72,3	42,3	36,0	29,1	26,1	18,1	18,1
4,3	6,3	56,2	32,9	28,0	22,6	20,3	14,1	14,1

Table J.7 – Detail categories for butt-welded joints between members

Detail type	Detail category $\Delta\sigma - m_1$ ¹⁾	Constructional detail Initiation site	Type of weld	Joint Part	Stress analysis	Execution requirements				
						Welding requirements	Quality level ³⁾		additional	
							internal	surface and geometric		
7.1.1	56-7		Full penetration, caps ground flush both sides	Flats, solids	Net section	Root ground off	Extension plates used on ends, cut off and ground flush in direction of stress	B	B	6)
7.1.2	45-7			Open shapes				C	C	
7.2.1	50-4,3		Welded from both sides, full penetration	Flats, solids	Net section	Root ground off	Extension plates used on ends, cut off and ground flush in direction of stress	B	B	4) 6)
7.2.2	40-3,4			Open shapes				B	C	6)
7.2.3	36-3,4			Weld toe				C	C	
7.3.1	40-4,3		Welded one side only, full penetration with permanent backing	Flats, solids	Net section	Root ground off	Extension plates used on ends, cut off and ground flush in direction of stress	C	C	6)
7.3.2	32-3,4			Open shapes, hollow, tubular				C	C	
7.4.1	45-4.3		Welded one side only, full penetration without backing	Flats, solids	Net section	Root ground off	Extension plates used on ends, cut off and ground flush in direction of stress	B	B	5) 6)
7.4.2	40-4,3			Open shapes, hollow, tubular				C	C	6)
7.4.3	32-3,4			Weld toe				C	C	
7.5	18-3,4		Partial penetration		Net throat			D	D	
7.6	36-3,4		Full penetration		Net section ²⁾			B	B	

¹⁾ $m_2 = m_1 + 2$

²⁾ Stress concentration of stiffening effect of transverse element already allowed for.

³⁾ According to EN ISO 10042:2005

⁴⁾ Overfill angle $\geq 150^\circ$ for both sides of the weld.

⁵⁾ Overfill angle $\geq 150^\circ$.

⁶⁾ Taper slope $< 1:4$ at width or thickness changes

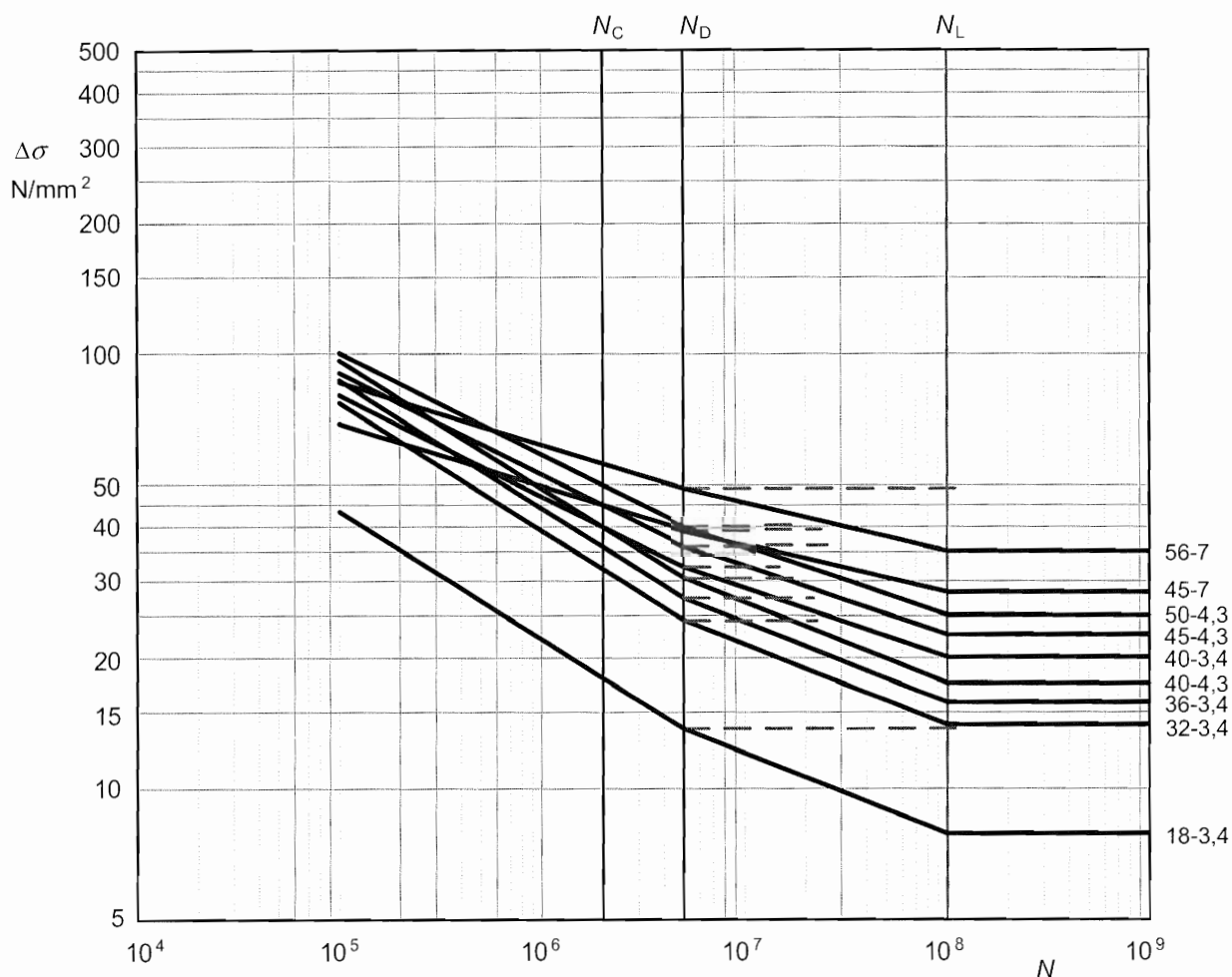
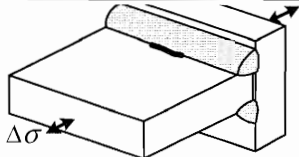
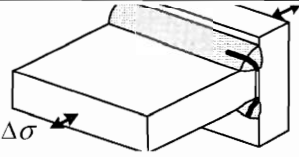
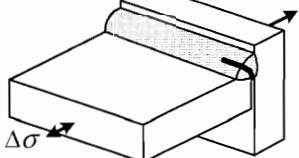
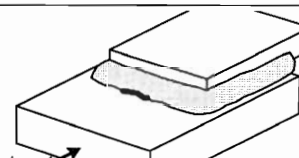
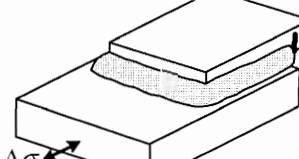
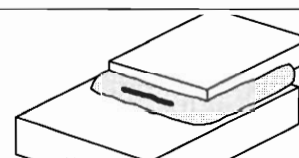

Figure J.4 —Fatigue strength curves $\Delta\sigma$ - N for butt welded joints between members
– detail categories as in Table J.7

Table J.8 – Numerical values of $\Delta\sigma$ - N (N/mm^2) for butt welded joints between members
– detail categories as in Table J.7

Slope		Cycles N						
m_1	m_2	1E+05	1E+06	2E+06	5E+06	1E+07	1E+08	1E+09
7	9	85,9	61,8	56,0	49,1	45,5	35,2	35,2
7	9	69,0	49,7	45,0	39,5	36,6	28,3	28,3
4,3	6,3	100,4	58,7	50,0	40,4	36,2	25,1	25,1
4,3	6,3	90,3	52,9	45,0	36,4	32,6	22,6	22,6
3,4	5,4	96,5	49,0	40,0	30,6	26,9	17,5	17,5
4,3	6,3	80,3	47,0	40,0	32,3	29,0	20,1	20,1
3,4	5,4	86,9	44,1	36,0	27,5	24,2	15,8	15,8
3,4	5,4	77,2	39,2	32,0	24,4	21,5	14,0	14,0
3,4	5,4	43,4	22,1	18,0	13,7	12,1	7,9	7,9

Table J.9 – Detail categories for fillet-welded joints between members

Detail type	Detail category $\Delta\sigma - m_1$ ¹⁾	Constructional detail Initiation site	Type of weld	Stress analysis		Execution requirements			
				Stress parameter	Stress concentrations already allowed for	Welding requirement	Quality level ³⁾		additional
							internal	surface and geometric	
9.1	28-3,4	 Weld toe	Double fillet weld partial penetration; toe crack for $alt > 0,6$	Net section	Stiffening effect of transverse element	Extension plates used on ends, cut off and ground flush in direction of $\Delta\sigma$	C	C	
9.2	25-3,4	 Weld	Double fillet weld partial penetration; root crack for $alt \leq 0,6$	Net throat			C	C	
9.3	12-3,4	 Weld	One sided fillet weld ²⁾ , root crack for $alt \leq 0,6$	Net throat			C	C	
9.4	23-3,4	 Weld toe	Fillet weld	Net section	Stress peak at weld ends	C	C		
9.5	18-3,4	 Weld toe	Fillet weld			C	C		
9.6	14-3,4	 Weld	Fillet weld	Net throat, see 5.4.2		C	C		

¹⁾ $m_2 = m_1 + 2$

²⁾ In case of tubular cross section design to detail type 9.1 or 9.2 accordingly.

³⁾ According to EN ISO 10042:2005.

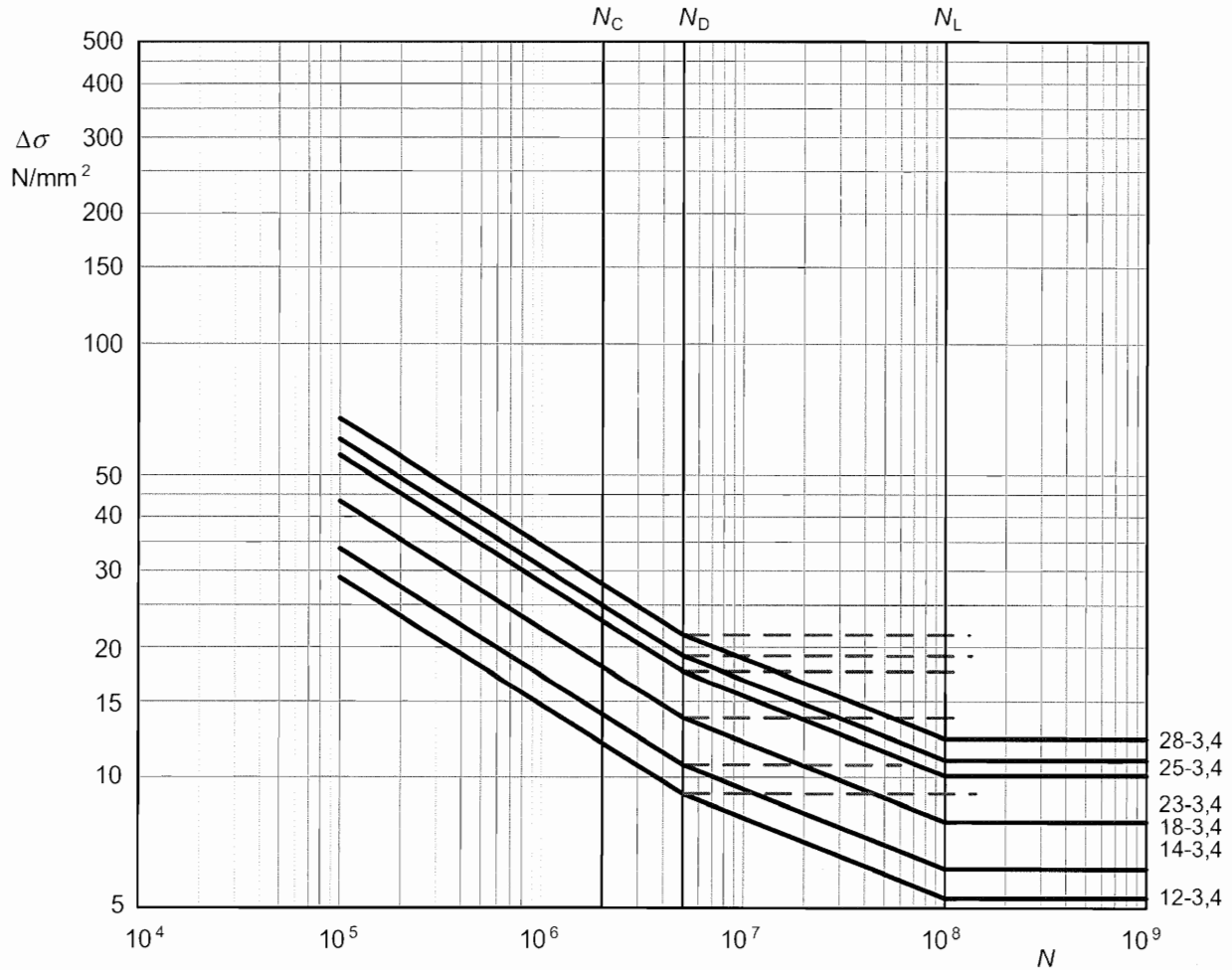
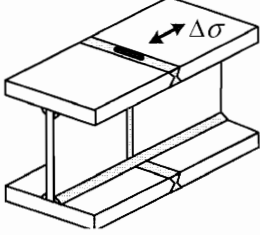
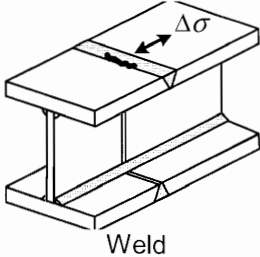
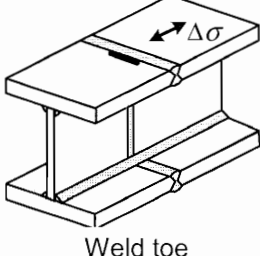
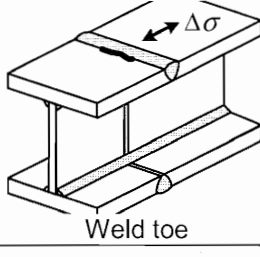

Figure J.5 – Fatigue strength curves $\Delta\sigma$ - N for fillet-welded joints between members – detail categories as in Table J.9

Table J.10 – Numerical values of $\Delta\sigma$ - N (N/mm^2) for fillet-welded joints between members – detail categories as in Table J.9

Slope		Cycles N						
m_1	m_2	1E+05	1E+06	2E+06	5E+06	1E+07	1E+08	1E+09
3,4	5,4	67,6	34,3	28,0	21,4	18,8	12,3	12,3
3,4	5,4	60,3	30,7	25,0	19,1	16,8	11,0	11,0
3,4	5,4	55,5	28,2	23,0	17,6	15,5	10,1	10,1
3,4	5,4	43,4	22,1	18,0	13,7	12,1	7,9	7,9
3,4	5,4	33,8	17,2	14,0	10,7	9,4	6,1	6,1
3,4	5,4	29,0	14,7	12,0	9,2	8,1	5,3	5,3

Table J.11 – Detail categories for crossing welds on built-up beams

Detail type	Detail category $\Delta\sigma - m_1$ ¹⁾	Constructional detail Initiation site	Type of weld ^{2) 3)}	Stress analysis	Execution requirements				
					Welding requirements	Quality level ⁴⁾		additional	
						internal	surface and geometric		
11.1	40-3,4	 Weld	Double sided butt weld, full penetration, caps ground flush both sides	Net section	Extension plates used on ends, cut off and ground flush in direction of $\Delta\sigma$	Root ground off	B	B	For web-to-flange fillet welds, see Table J.5, type no. 5.4 or 5.5
11.2	40-3,4	 Weld	Single sided butt weld, full penetration, root and cap ground flush			B	B		
11.3	36-3,4	 Weld toe	Double sided butt weld, full penetration			Overfill angle $\geq 150^\circ$ root ground off	B	C	
11.4	32-3,4	 Weld toe	Single sided butt weld, full penetration			C	C		

¹⁾ $m_2 = m_1 + 2$
²⁾ Transverse web and flange butt joint before final assembly of beam with longitudinal welds.
³⁾ Taper slope < 1:4 at width or thickness change.
⁴⁾ According to EN ISO 10042:2005.

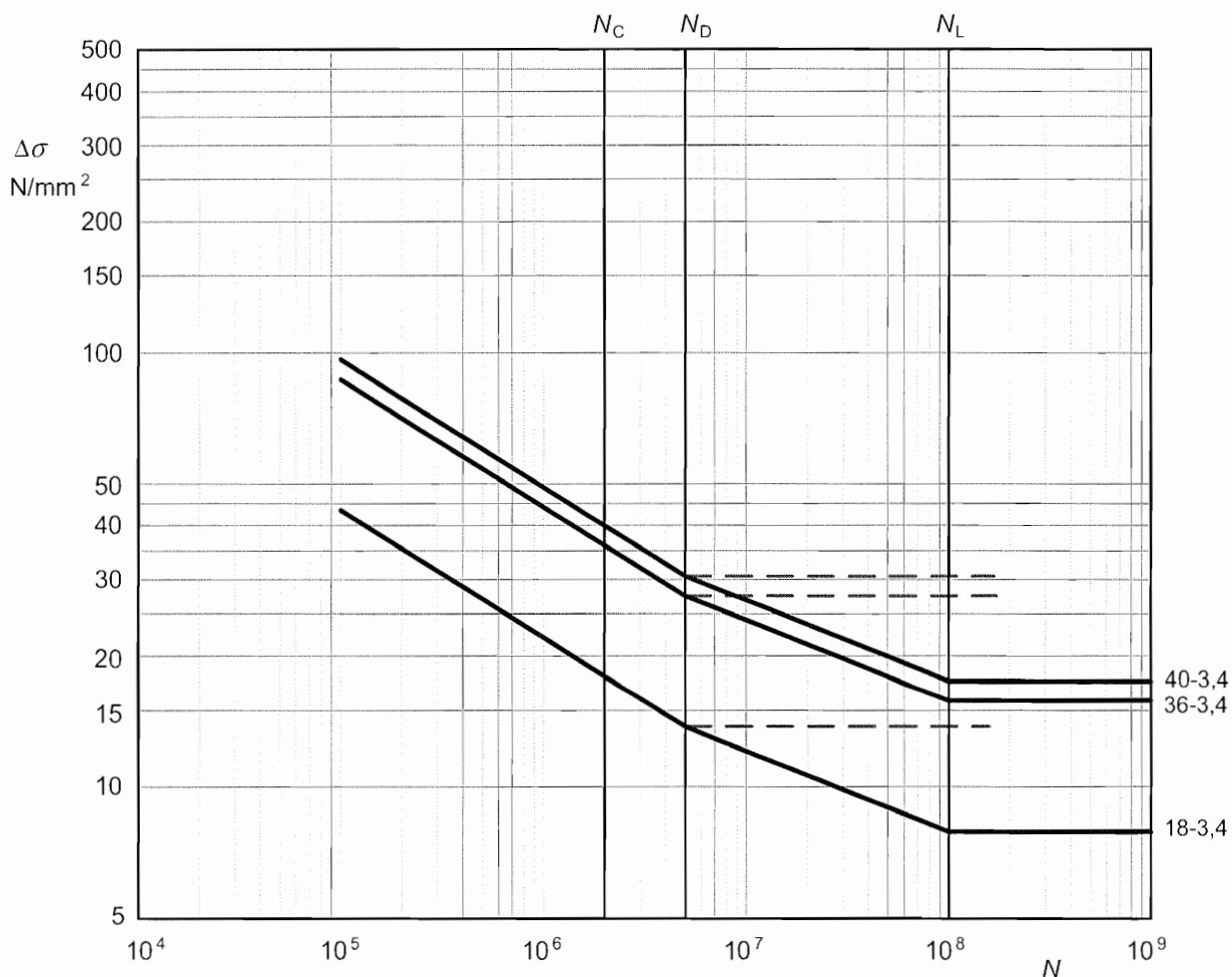
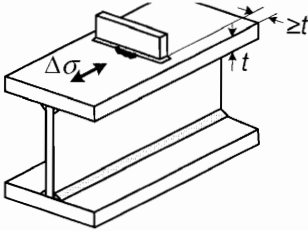
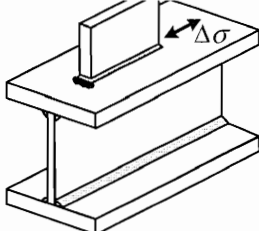
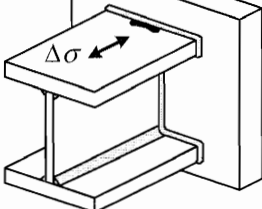
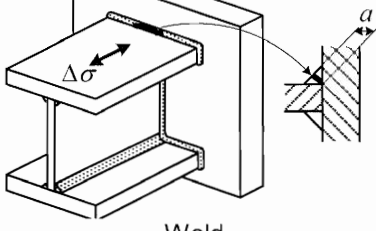
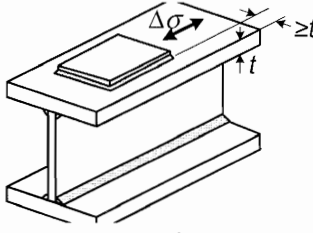

Figure J.6 – Fatigue strength curves $\Delta\sigma$ - N for crossing welds on built-up beams – detail categories as in Table J.11

Table J.12 – Numerical values of $\Delta\sigma$ - N (N/mm^2) crossing welds on built-up beams – detail categories as in Table J.11

Slope		Cycles N						
m_1	m_2	1E+05	1E+06	2E+06	5E+06	1E+07	1E+08	1E+09
3,4	5,4	96,5	49,0	40,0	30,6	26,9	17,5	17,5
3,4	5,4	86,9	44,1	36,0	27,5	24,2	15,8	15,8
3,4	5,4	43,4	22,1	18,0	13,7	12,1	7,9	7,9

Table J.13 – Detail categories for attachments on built-up beams

Detail type	Detail category $\Delta\sigma - m_1$ ¹⁾	Constructional detail Initiation site	Type of weld	Stress analysis		Execution requirements			
				Stress parameter	Stress concentrations already allowed for	Quality level ²⁾		additional	
						internal	surface and geometric		
13.1	23-3,4	 Weld toe	Transverse attachment, thickness < 20 mm, welded on one or both sides	Net section	Stiffening effect of attachment / stress concentration at "hard point" of connection (compare to Figure 5.2)	C	C	For web-to-flange fillet welds, see Table J.5, type no. 5.4 or 5.5	
13.2	18-3,4	 Weld toe	Longitudinal attachment length ≥ 100 mm, welded on all sides						
13.3	32-4,3	 Weld toe	Cruciform or tee, full penetration						
13.4	25-4,3	 Weld	Cruciform or tee, double sided fillet welds; root crack for $a/t \leq 0,6$						Net throat
13.5	20-4,3	 Weld toe	Coverplate length ≥ 100 mm, welded on all sides						Net section

¹⁾ $m_2 = m_1 + 2$

²⁾ According to EN ISO 10042:2005.

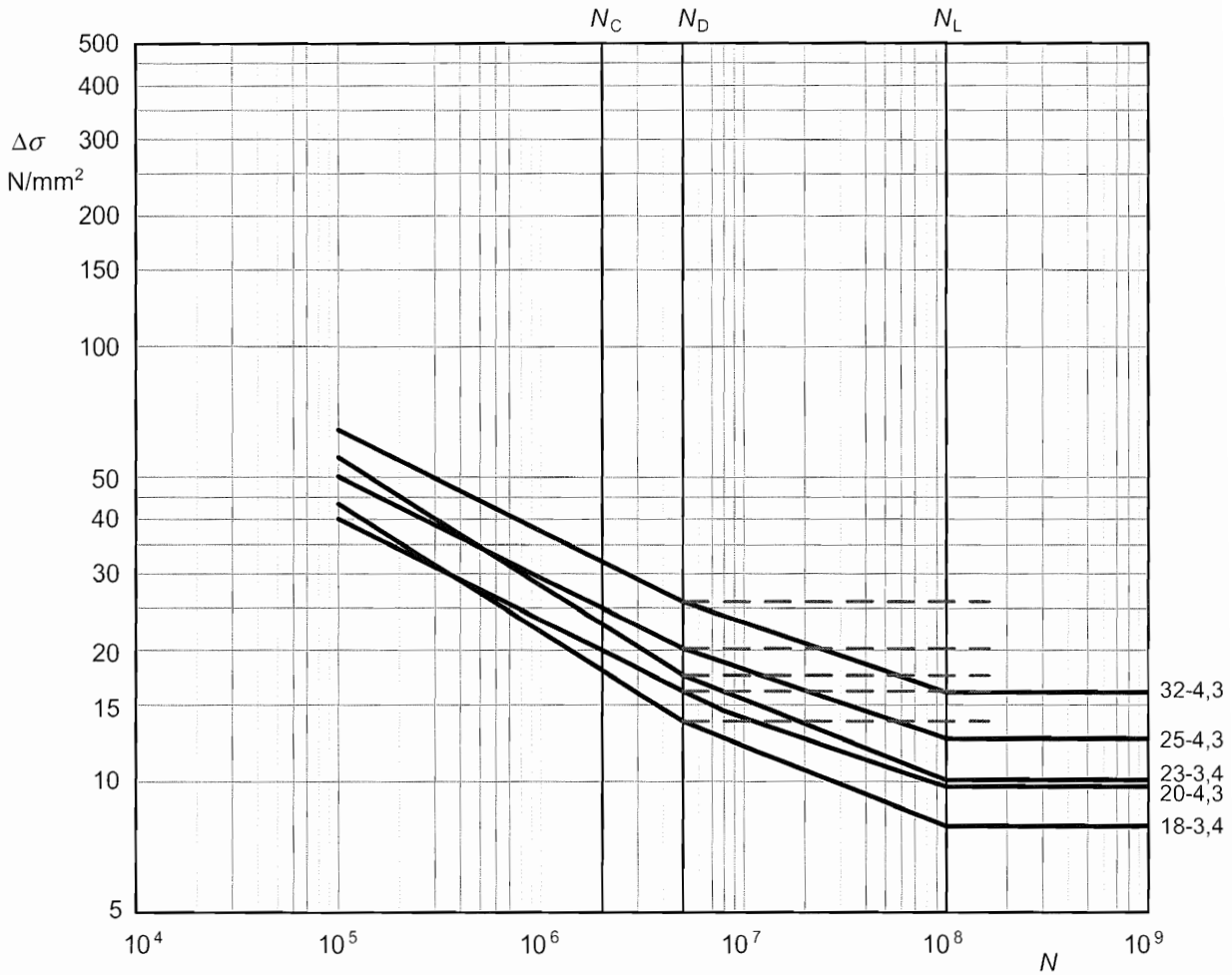
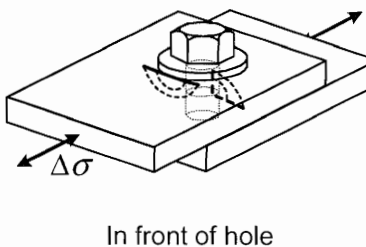
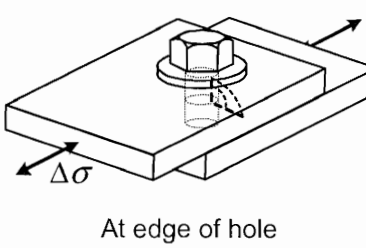

Figure J.7 – Fatigue strength curves $\Delta\sigma$ - N for attachments on built-up beams – detail categories as in Table J.13

Table J.14 – Numerical values of $\Delta\sigma$ - N (N/mm²) for attachments on built-up beams – detail categories as in Table J.13

Slope		Cycles N						
m_1	m_2	1E+05	1E+06	2E+06	5E+06	1E+07	1E+08	1E+09
4,3	6,3	64,2	37,6	32,0	25,9	23,2	16,1	16,1
4,3	6,3	50,2	29,4	25,0	20,2	18,1	12,6	12,6
3,4	5,4	55,5	28,2	23,0	17,6	15,5	10,1	10,1
4,3	6,3	40,1	23,5	20,0	16,2	14,5	10,0	10,0
3,4	5,4	43,4	22,1	18,0	13,7	12,1	7,9	7,9

Table J.15 – Detail categories for bolted joints

Detail type	Detail category $\Delta\sigma - m_1$ 1)	Constructional detail Initiation site	Stress analysis		Execution requirements
			Stress parameter	Stress concentrations already allowed for	
15.1	56-4	<p>Preloaded (friction type), high strength steel bolt</p>  <p>In front of hole (sometimes at edge of hole)</p>	Nominal stress based on gross section properties	<p>Surface texture, fastener hole geometry;</p> <p>unequal load distribution between rows of bolts;</p>	<p>Lap joint with flat parallel surfaces</p> <p>Machining only by high speed milling cutter; holes drilled (with optional reaming) or punched (with compulsory reaming if thickness > 6 mm)</p> <p>For preloaded bolts the quality should be 8.8 ($f_y \geq 640 \text{ N/mm}^2$) or higher see EN 1999-1-1.</p>
15.2	56-4	<p>Non-preloaded (bearing type) steel bolt</p>  <p>At edge of hole</p>	Nominal stress based on net section properties	eccentricity of load path in symmetrical double covered lap joints only	<p>Lap joint with flat parallel surfaces</p> <p>Machining only by high speed milling cutter; holes drilled (with optional reaming) or punched (with compulsory reaming if thickness > 6 mm)</p> <p>For bolts see EN 1999-1-1.</p>

¹⁾ $m_1 = m_2$

²⁾ Verification of the resistance of steel bolts: see EN 1993-1-9.

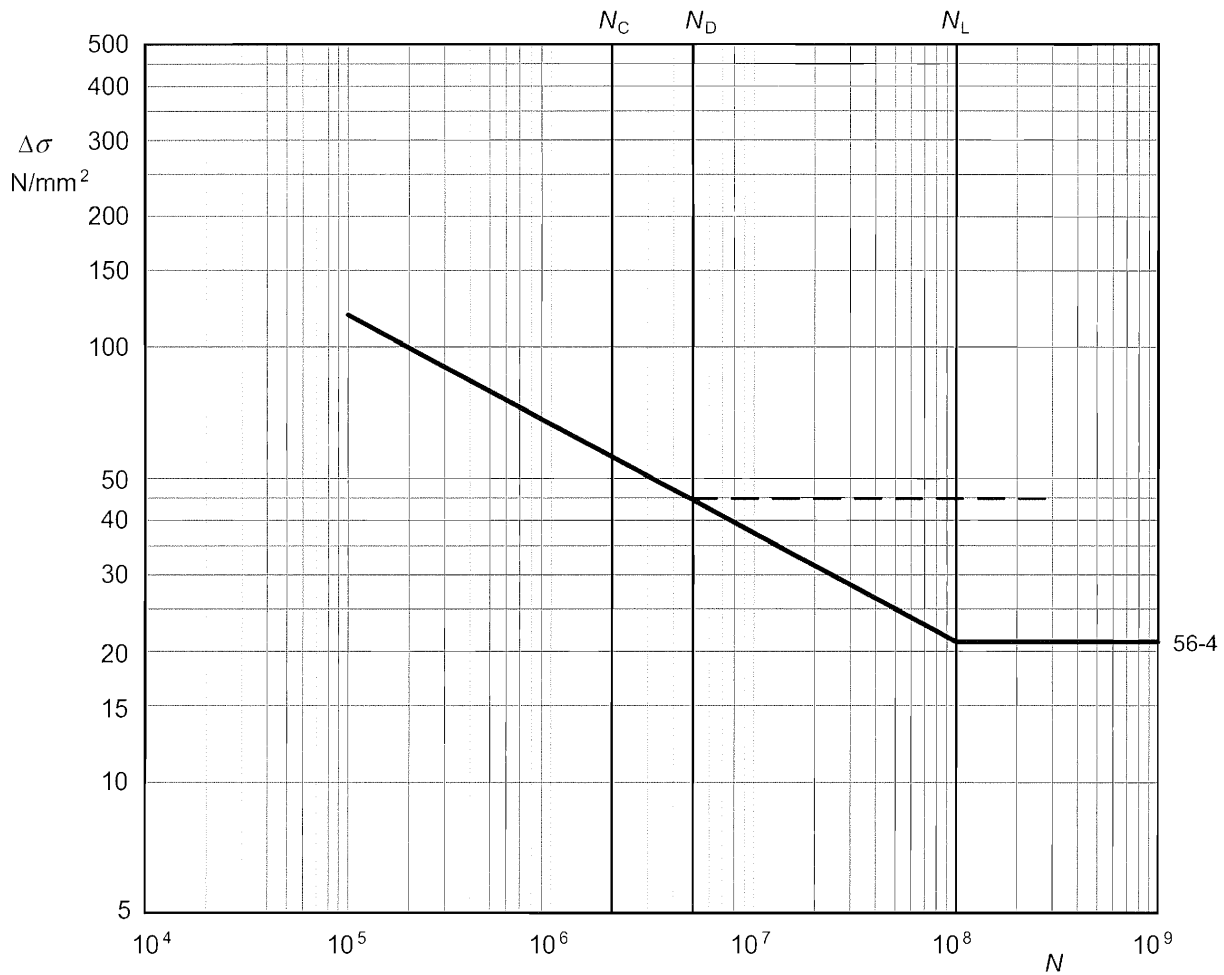

Figure J.8 – Fatigue strength curves $\Delta\sigma$ - N for bolted joints – detail categories as in Table J.15

Table J.16 – Numerical values of $\Delta\sigma$ - N (N/mm^2) for bolted joints – detail categories as in Table J.15

Slope		Cycles N						
m_1	m_2	1E+05	1E+06	2E+06	5E+06	1E+07	1E+08	1E+09
4	4	118,4	66,6	56,0	44,5	37,4	21,1	21,1

Annex K [informative]: Hot spot reference detail method

(1) For the hot spot reference detail fatigue strength method as defined in this Annex, data determined under the requirements of this Standard should be used.

(2) The calculation procedure is as follows:

- a) Select a reference detail with known fatigue resistance from the detail category tables, which is as similar as possible to the detail being assessed with respect to weld quality and to geometric and loading parameters;
- b) identify the type of stress in which the fatigue resistance is expressed. This is usually nominal stress (as in the detail category tables);
- c) establish a FEM model of the reference detail and the detail to be assessed with the same type of meshing and elements following the recommendations given in 5.1;
- d) load the reference detail and the detail to be assessed with the stress identified in b);
- e) determine the hot spot stress ranges $\Delta\sigma_{HS,ref}$ of the reference detail and the hot spot stress ranges $\Delta\sigma_{HS,assess}$ of the detail to be assessed;
- f) the fatigue strength for 2 million cycles of the detail to be assessed $\Delta\sigma_{C,assess}$ is then calculated from the fatigue class of the reference detail $\Delta\sigma_{C,ref}$ by:

$$\Delta\sigma_{C,assess} = \frac{\sigma_{HS,ref}}{\sigma_{HS,assess}} \Delta\sigma_{C,ref} \quad (K.1)$$

- g) g) assume for the detail to be assessed the same slopes m_1 , m_2 of the reference detail.

(3) In case control measurements are performed to verify the calculated stresses, a correct positioning of the strain gauges outside the heat affected zone should be assured.

NOTE Additional information to the reference detail method: see Bibliography D.3.

Annex L [informative]: Guidance on use of design methods, selection of partial factors, limits for damage values, inspection intervals and execution parameters when Annex J is adopted

L.1 Safe life method

(1) This guidance is only applicable when the fatigue resistance data in Annex J is adopted.

(2) One of two types of the safe life design approach may be used. The types are denoted SLD-I and SLD-II:

SLD-I requires no programme for regular inspection.

NOTE The term regular inspection covers both general inspection and fatigue inspection. See Table L.2 for clarification of the terms.

SLD-II requires a programme for general inspection which should be prepared in accordance with L.3.

NOTE As the proper implementation of the inspection programme during maintenance is a presumption for design, it will be important for the owner(s) to ensure that the inspection programme is followed during the lifetime of the structure.

(3) The safe life design approach should be used where there is no accessibility for fatigue inspection or where a fatigue inspection by other reasons is not presupposed.

NOTE To use SLD might give the most cost effective solution for cases where the costs for repair are assessed to be relatively high.

(4) For the case where all design stress ranges are under the design constant amplitude fatigue limit, the following condition should be fulfilled:

$$\frac{\gamma_{Ff} \Delta \sigma}{\Delta \sigma_D / \gamma_{Mf}} \leq 1 \quad (\text{L.1})$$

NOTE 1 For γ_{Mf} , see L.4. For γ_{Ff} , see 2.4.

(5) Stress range spectra may be modified by neglecting design peak values of stress ranges representing a contribution to the damage value ($D_{L,d}$) of less than 0,01.

L.2 Damage tolerant design method

L.2.1 General

(1) This guidance is only applicable when the fatigue resistance data in Annex J is adopted.

(2) One of two types of Damage Tolerant Design may be used. The types are denoted DTD-I and DTD-II, see L.2.2 and L.2.3. **A1**

A1 L.2.2 DTD-I

(1) DTD-I is based on any crack detected during inspection being repaired or the component being replaced.

(2) A programme for regular inspection should be prepared in accordance with L.3.

NOTE As the proper implementation of the inspection programme during maintenance is a presumption for design, it will be important for the owner(s) to ensure that the inspection programme is followed during the lifetime of the structure.

(3) One of two options for DTD-I should be used. The options are denoted DTD-IA and DTD-IB:

- a) for option DTD-IA the structure should have sufficient redundancy, in terms of being statically indeterminate, to redistribute the load effects such that any initiated crack propagation will stop, and the structure remains capable of carrying the redistributed load effects;
- b) for option DTD-IB the structure should have sufficient large sections to carry the load effects after the first cracks detectable by the naked eye have occurred. Such cracks should not lead to collapse of the structure. The rest capacity for the quasi-static design loads after cracking should be demonstrated. It should be required that in the event of detected cracks, the structure should be repaired or the crack growth stopped by efficient means.

(4) The DTD-I type of approach may be based on one of two methods to ensure sufficient resistance of the component or structure. The methods are respectively based on:

- a) linear damage accumulation calculation, see (5);
- b) equivalent stress range, see (6).

(5) For DTD-I the design damage value D_L for all cycles based on a linear damage accumulation should fulfill the condition:

$$D_{L,d} \leq 1 \quad (\text{L.1})$$

or

$$D_L \leq D_{lim} \quad (\text{L.2})$$

where

$D_{L,d} = \sum n_i / N_i$ is calculated in accordance with the procedure given in A.2;

$D_L = \sum n_i / N_i$ is calculated in accordance with the procedure given in A.2 with $\gamma_{Mf} = \gamma_{Ff} = 1,0$.

NOTE The national annex may specify values for D_{lim} . Recommended values are given in L.4.

(6) For the case where the design is based on the equivalent stress range approach ($\Delta\sigma_{E,2e}$) the following condition should be fulfilled:

$$\frac{\gamma_{Ff} \Delta\sigma_{E,2e}}{\Delta\sigma_C / \gamma_{Mf}} \leq 1 \quad (\text{L.3})$$

L.2.3 DTD-II

(1) P DTD-II allows fatigue induced cracks in the structure provided that the crack growth is monitored and kept under control by means of a fatigue inspection programme based on the use of fracture mechanics.

NOTE For inspection programmes, see L.3. **A1**

Ⓐ₁) (2) The minimum detectable crack size at potential crack initiation sites should be determined.

(3) P The structure shall have sufficient large sections to carry the design load effects after the first cracks detectable by the naked eye have occurred.

(4) The stress histories at the crack initiation sites, followed by counting of stress intensity ranges and compilation of stress intensity spectra should be calculated.

(5) Based on (2) and (4), the crack growth relationship for the alloy should be used to calculate the crack growth rate by use of a fracture mechanics approach. Using this approach, the time taken for the minimum detectable crack size to grow to the maximum safe crack size should be estimated.

This estimated time should be accounted for in the specifications of the corresponding fatigue inspection programme.

NOTE Recommendations for crack growth data are given in Annex B.

(6) The remaining capacity for quasi-static design loads after cracking should be demonstrated.

(7) A programme for regular inspection and monitoring of any crack growth should be prepared based on (6). The time for start of inspection and the maximum inspection intervals should be specified, see L.3.

NOTE As the proper implementation of the inspection programme during maintenance is a presumption for design, it will be important for the owner(s) to ensure that the inspection programme is followed during the lifetime of the structure, see L.3.

(8) D_L for DTD-II should satisfy the following:

$$D_{L,d} \leq D_{lim} \quad (L.4)$$

where D_{lim} is greater than 1,0, but should be limited, see L.4.

L.3 Start of inspection and inspection intervals

(1) This guidance is only applicable when the fatigue resistance data in Annex J is adopted.

(2) The inspection programmes should specify a time after erection for start of inspection and the inspection intervals.

NOTE The national annex may specify the start of inspection and the inspection intervals. Recommendations are given in Table L.1.

(3) For DTD-I, the value of T_S to be used to determine T_F and ΔT_F should be calculated according to A.2.1 (5). Unless otherwise specified the time interval between the inspections should not be larger than $T_S/4$.

(4) For DTD-II the value of T_S to be used to determine T_F should be calculated according to A.2.1 (5). ΔT_F should be determined using fracture mechanics. Ⓐ₁)

Table L.1 – Recommended start of inspection and maximum inspection intervals

Design approach	Design procedure	Type of design approach	Recommended start of inspection ^a	Recommended maximum inspection intervals
Safe Life Design SLD	Damage accumulation	SLD-I	-	-
		SLD-II	$T_G = 0$	$\Delta T_G = 6$ years
	Constant amplitude fatigue limit (i.e. $\max \Delta\sigma_{E,d} < \Delta\sigma_{D,d}$)	SLD-I	-	-
		SLD-II	$T_G = 0$	$\Delta T_G = 6$ years
Damage Tolerant Design DTD	Damage accumulation	DTD-IA	$T_G = 0$ $T_F = 0,5 T_S$	$\Delta T_G = 6$ years $\Delta T_F = 0,25 T_S$
		DTD-IB	$T_G = 0$ $T_F = 0,5 T_S$	$\Delta T_G = 6$ years $\Delta T_F = 0,25 T_S$
	Damage accumulation and fracture mechanics	DTD-II	$T_G = 0$ $T_F = 0,8 T_S$	$\Delta T_G = 6$ years ΔT_F is determined by fracture mechanics

^a T_G is the recommended time after completed erection for start of general inspection. The general inspection comprises checking that the structure is as it was when it was completed and approved, i.e. that no deterioration has taken place, such as deterioration caused by adding detrimental holes or welds for additional elements, damage due to vandalism or accidents, unexpected corrosion etc.

ΔT_G is the recommended maximum time interval for general inspection.

T_F is the recommended time after completed erection for the start of fatigue inspection. The fatigue inspection comprises the inspection of areas with high probability for cracks.

ΔT_F is the recommended maximum time interval for fatigue inspection.

L.4 Partial factors γ_{Mf} and the values of D_{Lim}

(1) This guidance is only applicable when the resistance data in Annex J is adopted.

(2) Fatigue assessment should be based either on a design fatigue strength value derived by using a partial safety factor γ_{Mf} for the characteristic fatigue strength $\Delta\sigma_{if}$ or by defining a limit value D_{Lim} for the design damage value D_L , taking into account the consequence class and the design method used.

(3) P The safety concept should be based on the application of γ_{Ff} , γ_{Mf} and D_{Lim} and the requirements for the inspection programmes as given in L.3.

NOTE 1 The national annex may specify values for γ_{Mf} . Recommended values are given in Table L.2 which are based on a value for γ_{Ff} equal to 1,0.

NOTE 2 The national annex may specify execution class instead of consequence class as a criterion for selection of the value for γ_{Mf} in Table L.2.

(4) The values of the safety element D_{Lim} should be specified.

NOTE The national annex may specify values for D_{Lim} . It is recommended to specify values within the following range

$$\left(\frac{1}{\gamma_{Ff} \cdot \gamma_{Mf}}\right)^{m_2} \leq D_{lim} \leq \left(\frac{1}{\gamma_{Ff} \cdot \gamma_{Mf}}\right)^{m_1} \tag{L.5}$$

(5) For DTD-II the Value of D_{lim} is larger than 1 but should be limited. **A1**

A1 NOTE The national annex may specify values for D_{lim} see L.2.3 (8). Recommended values are 2,0 for welded, bolted or riveted details and 4,0 for plain parts.

Table L.2 – Recommended γ_{Mf} – values in relation to the consequence class

Design approach	Design procedure	Consequence class		
		CC1	CC2	CC3
		$\gamma_{Mf}^{a b c d}$	$\gamma_{Mf}^{a b c d}$	$\gamma_{Mf}^{a b c d}$
SLD-I	Damage accumulation	1,1	1,2	1,3
	Constant amplitude fatigue (i.e. $\max \Delta\sigma_{E,d} < \Delta\sigma_{D,d}$)	1,1	1,2	1,3
SLD-II	Damage accumulation	1,0	1,1	1,2
	Constant amplitude fatigue (i.e. $\max \Delta\sigma_{E,d} < \Delta\sigma_{D,d}$)	1,0	1,1	1,2
DTD-I	Damage accumulation	1,0	1,0	1,1
DTD-II	Damage accumulation	1,0	1,0	1,1

^a The values of the table may be reduced according to footnotes a to d below provided that the value of γ_{Mf} does not become less than 1,0.

^b The above tabled γ_{Mf} -values may be reduced by 0,1 if one of the following conditions apply:

- non-welded areas of welded components;
- detail categories where $\Delta\sigma_c < 25 \text{ N/mm}^2$;
- welded components where the largest stress range represents all cycles;
- additional NDT for a minimum of 50 % is carried out.

For adhesively bonded joints, see Annex E (5).

^c The above tabled γ_{Mf} -values may be reduced by 0,2 if one of the following conditions apply:

- non-welded areas of welded components where the largest stress range represents all cycles;
- detail categories where $\Delta\sigma_c < 25 \text{ N/mm}^2$ and where the largest stress range represents all cycles;
- non-welded components and structures;
- additional NDT for a minimum 50 % is carried out where the largest stress range represents all cycles;
- if additional NDT of 100 % is carried out.

^d The above tabled γ_{Mf} -values may be reduced by 0,3 if one of the following conditions apply:

- non-welded components and structures where the largest stress range represents all cycles;
- additional NDT for 100 % is carried out where the largest stress range represents all cycles.

L.5 Parameters for execution

L.5.1 Service category

(1) If the resistance data of Annex J are adopted, the criteria a), b) or c) below should be used to classify components as service category SC1:

a) if the largest nominal stress range $\Delta\sigma_{E,k}$ satisfies **A1**

$$\boxed{A_1} \text{ — } \gamma_{Ff} \cdot \Delta\sigma_{E,k} \leq \frac{13,7}{\gamma_{Mf}} \frac{N}{\text{mm}^2} \quad \text{for parent material (including HAZ and butt welds);} \quad (\text{L.6})$$

$$\text{— } \gamma_{Ff} \cdot \Delta\sigma_{E,k} \leq \frac{9,2}{\gamma_{Mf}} \frac{N}{\text{mm}^2} \quad \text{for fillet welds,} \quad (\text{L.7})$$

where

values for γ_{Mf} are given in L.4 (3) P. The values given for SLD-I should be used.

$\Delta\sigma_{E,k}$ is the characteristic value of the action effect (stress range);

b) for cases of fatigue loading spectra ($\Delta\sigma_{E,k,i}$) if L.5.2 is used to calculate the fatigue utilization grade U , and U does not exceed the value 1,0 where the fatigue resistance is based on:

- for parent material (including HAZ and butt welds), detail category 18-3,4;
- for fillet welds, detail category 12-3,4.

Values of γ_{Mf} for calculating U are given in L.4 (3) P. The values given for SLD-I should be used. For cases where the largest stress amplitude represents all cycles, the values may be reduced by 0,1.

c) for cases where the limit values according to the criteria of a) or b) are exceeded, and if the fatigue utilization grade U according to L.5.2 does not exceed the value of 0,5, and where the fatigue resistance is based on the lowest values for the following cases:

- for parent material (not influenced by welding), detail category 71-7;
- for continuous longitudinal welds (stress direction parallel to weld axis), detail category 40-4,3;
- for butt welds, detail category 36-3,4.

Values of γ_{Mf} for calculating U are given in L.4 (3) P. The values given for SLD-I should be used. For cases where the largest stress amplitude represents all cycles, the values may be reduced by 0,1, but with the resulting γ_{Mf} not less than 1,0.

NOTE The national annex may specify other or additional criteria for defining the service category.

L.5.2 Calculation of utilisation grade

(1) This sub-clause gives provisions for calculation of the utilization grade U for components subject to fatigue if fatigue resistance data according to Annex J have been used for design and EN 1090-3:2008, Annexes L and M have been selected for specifying quality and inspection requirements. The calculated values are used to distinguish between the two service categories SC1 and SC2.

NOTE 1 The definition of the service categories is given in EN 1999-1-1.

NOTE 2 EN 1090-3 gives the criteria for determination of the scope of inspection and the quality level requirements for the two service categories as well as quantitative criteria for inspection of welds, depending on the execution class and the utilization grade.

(2) The utilization grade for fatigue for a constant stress range for a limited number of cycles n is defined by:

$$U = \frac{\Delta\sigma_{E,k} \cdot \gamma_{Ff}}{\frac{\Delta\sigma_{R,k}}{\gamma_M}} \quad (\text{L.8}) \quad \boxed{A_1}$$

A1 where

$\Delta\sigma_{E,k}$ is the characteristic stress range (for combined stress, the principal stress) in the section under consideration for a given number of cycles n ;

$\Delta\sigma_{R,k}$ is the corresponding strength range value of the relevant fatigue strength curve $\Delta\sigma-N$ for the given number of cycles n .

(3) For the case of fatigue with all stress ranges less than $\Delta\sigma_D$ and an unlimited number of cycles, the utilization grade is defined as follows:

$$U = \frac{\Delta\sigma_{E,k} \cdot \gamma_{Ff}}{\frac{\Delta\sigma_D}{\gamma_M}} \quad (\text{L.9})$$

where

$\Delta\sigma_{E,k}$ is the largest stress range.

$\Delta\sigma_D$ is the constant amplitude fatigue limit

(4) If the calculation is based on the equivalent constant amplitude stress range $\Delta\sigma_{E,2e}$ the utilisation grade is defined as follows:

$$U = \frac{\gamma_{Ff} \Delta\sigma_{E,2e}}{\frac{\Delta\sigma_C}{\gamma_M}} \quad (\text{L.10})$$

where

$\Delta\sigma_C$ is the fatigue strength for 2×10^6 cycles.

(5) If the utilization grade U is based on the calculation of fatigue damage values according to linear damage accumulation, its value can, for the purpose of this annex, be calculated as follows:

$$U = \sqrt[m]{D_{L,d}} \quad (\text{L.11})$$

where

$D_{L,d}$ is calculated according to 2.2.1 and 6.2.1. **A1**

Bibliography

References to Annex B: Fracture mechanics

- B.1 Standard test method for measurement of fatigue crack growth rates, ASTM E647-93.
- B.2 Simulations of short crack and other low closure action conditions utilising constant $K_{max} / \Delta K$ -decreasing fatigue crack growth procedures. ASTM STP 1149-1992, pp.197-220.
- B.3 Graf, U.: Fracture mechanics parameters and procedures for the fatigue behaviour estimation of welded aluminium components. Reports from Structural Engineering, Technische Universität München, Report No. 3/92 (TUM-LME research rep. D. Kosteas), Munich, 1992.
- B.4 Ondra, R.: Statistical Evaluation of Fracture Mechanic Data and Formulation of Design Lines for welded Components in Aluminium Alloys. Reports from Structural Engineering, Technische Universität München, Report No. 4/98 (TUM-LME research rep. D. Kosteas), Munich, 1998.
- B.5 Stress intensity factor equations for cracks in three-dimensional finite bodies. ASTM STP 791, 1983, pp I-238 to I-265.

References to Annex C: Testing for fatigue design

- C.1 Kosteas, D.: On the Fatigue Behaviour of Aluminium. In: Kosteas, D.(Ed.), Aluminium in Practice, Stahlbau Spezial, issue No. 67(1998) Ernst & Sohn, Berlin.
- C.2 Jaccard, R., D. Kosteas, R. Ondra: Background Document to Fatigue Design Curves for welded Aluminium Components. IIW doc. No. XIII-1588-95.

References to Annex D: Stress analysis

- D.1 Pilkey, W. D.: Peterson`s stress concentration factors, John Wiley and Sons Inc., 1997.
- D.2 Young, W. C., Budynas R. G.: Roark`s formulas for stress and strain, McGraw Hill, 2001.
- D.3 Hobbacher, A: Recommendations on fatigue of welded components, IIW Doc. XIII-1965-03/XV-1127-03, July 2004.